

Panasonic



Cableado Serie KW9

Panasonic Corporation



1 Sistema monofásico, 2 Hilos

Alimentación: 85-264 VCA / 100-300 VCC

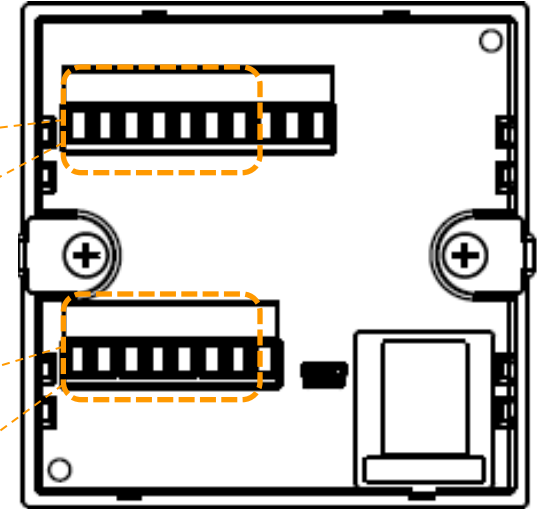
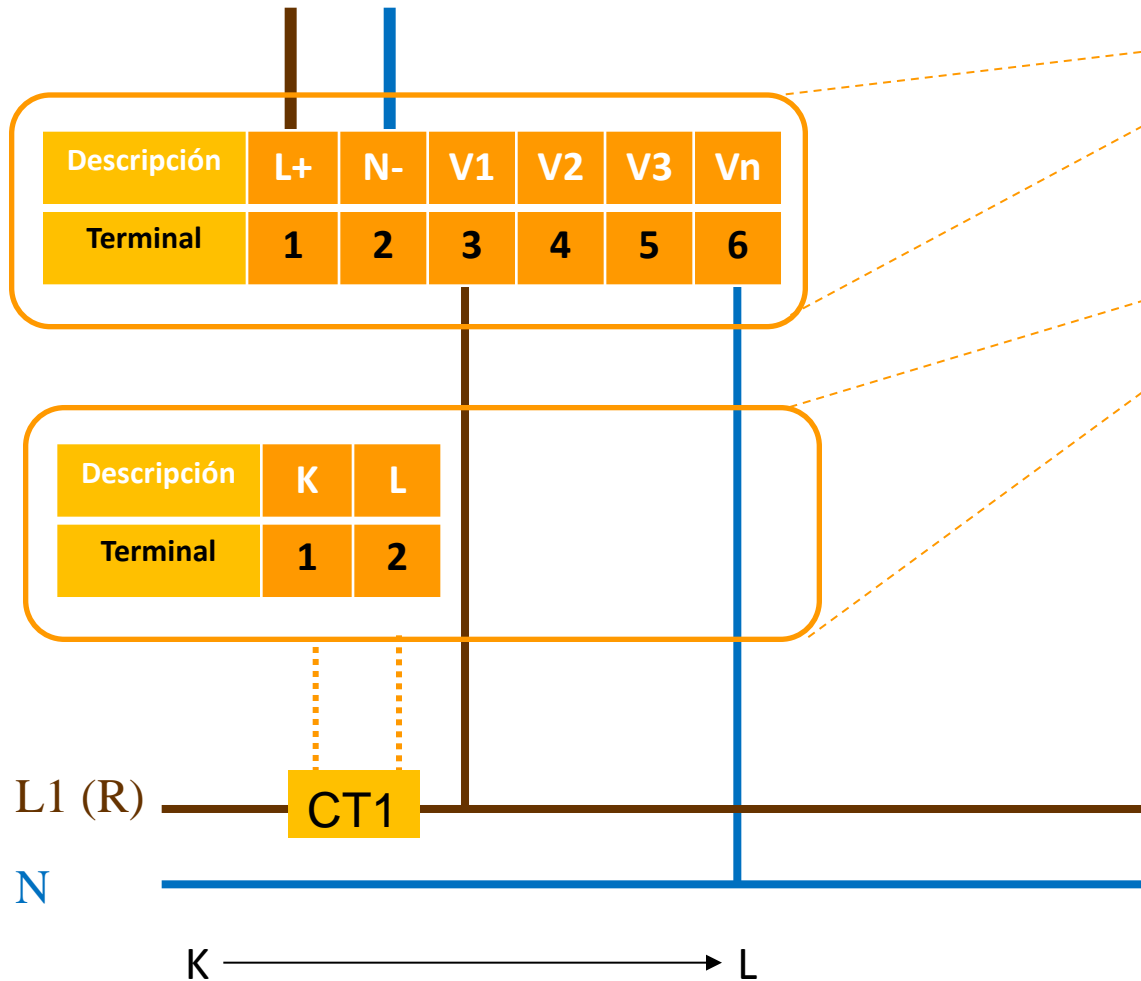

2 Sistemas monofásicos, 2 Hilos

Alimentación: 85-264 VCA / 100-300 VCC

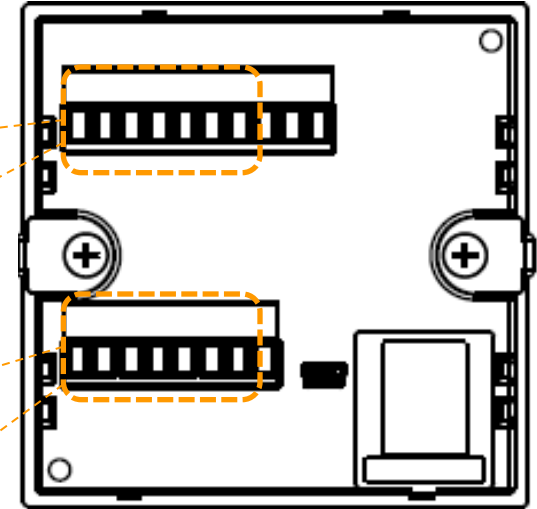
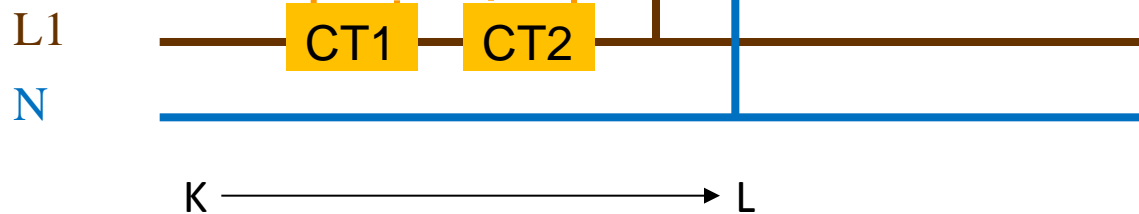
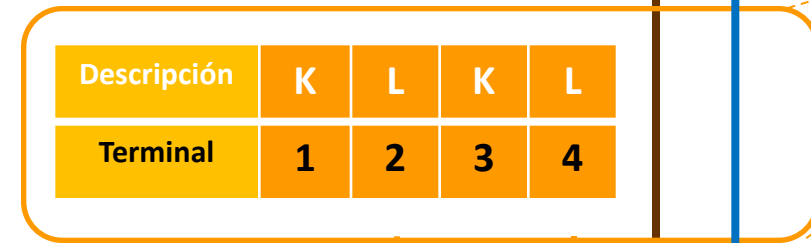
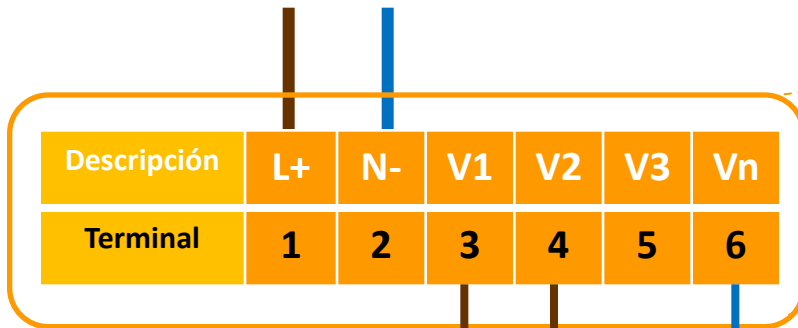

3 Sistemas monofásicos, 2 Hilos

Alimentación: 85-264 VCA / 100-300 VCC

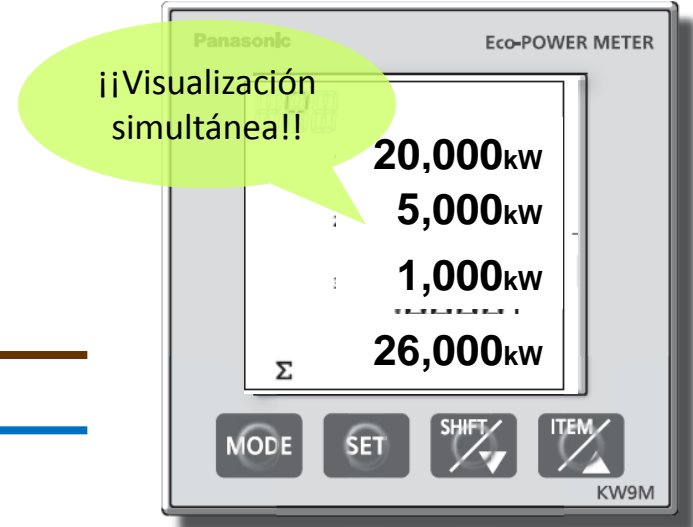
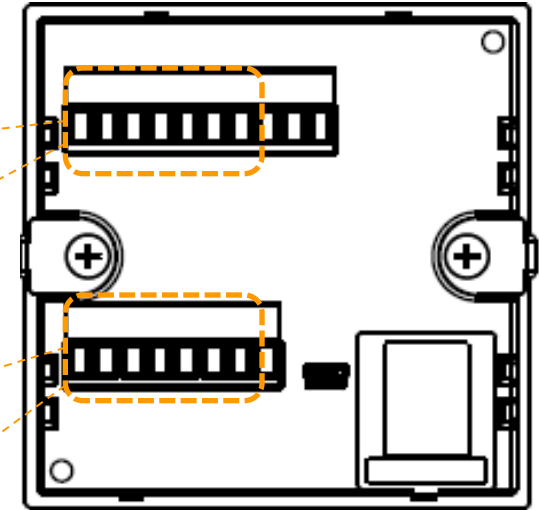
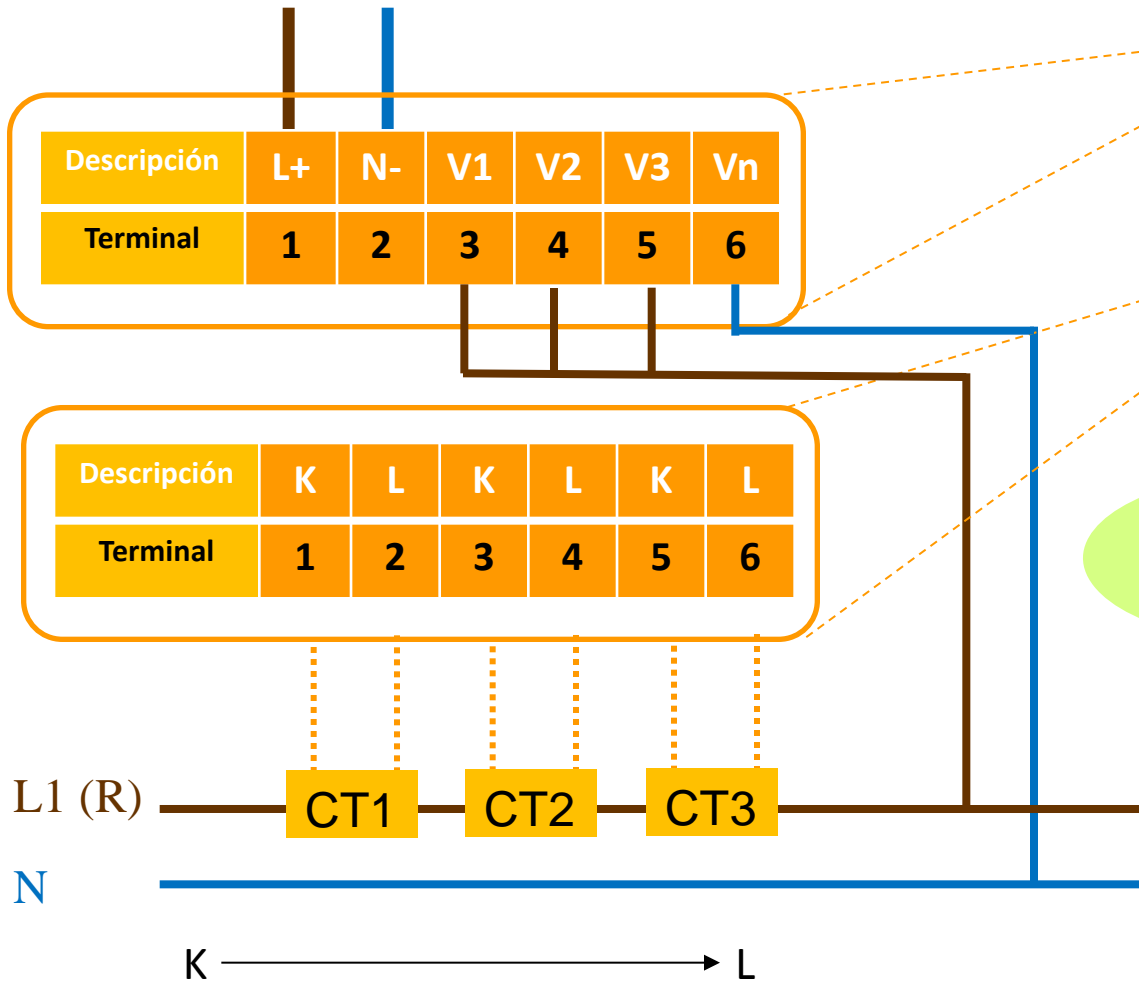

Sistemas monofásicos, 3 Hilos

Alimentación: 85-264 VCA / 100-300 VCC

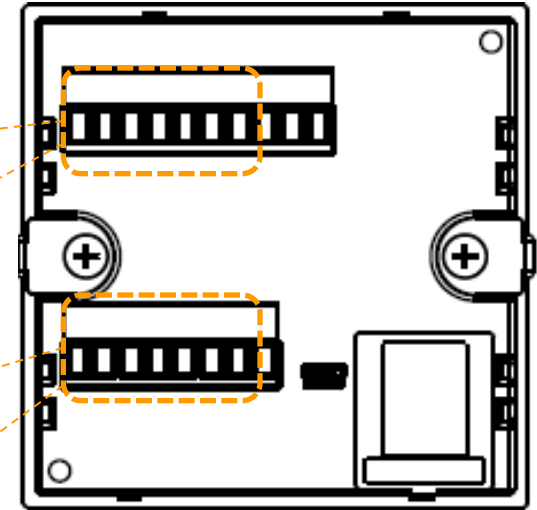
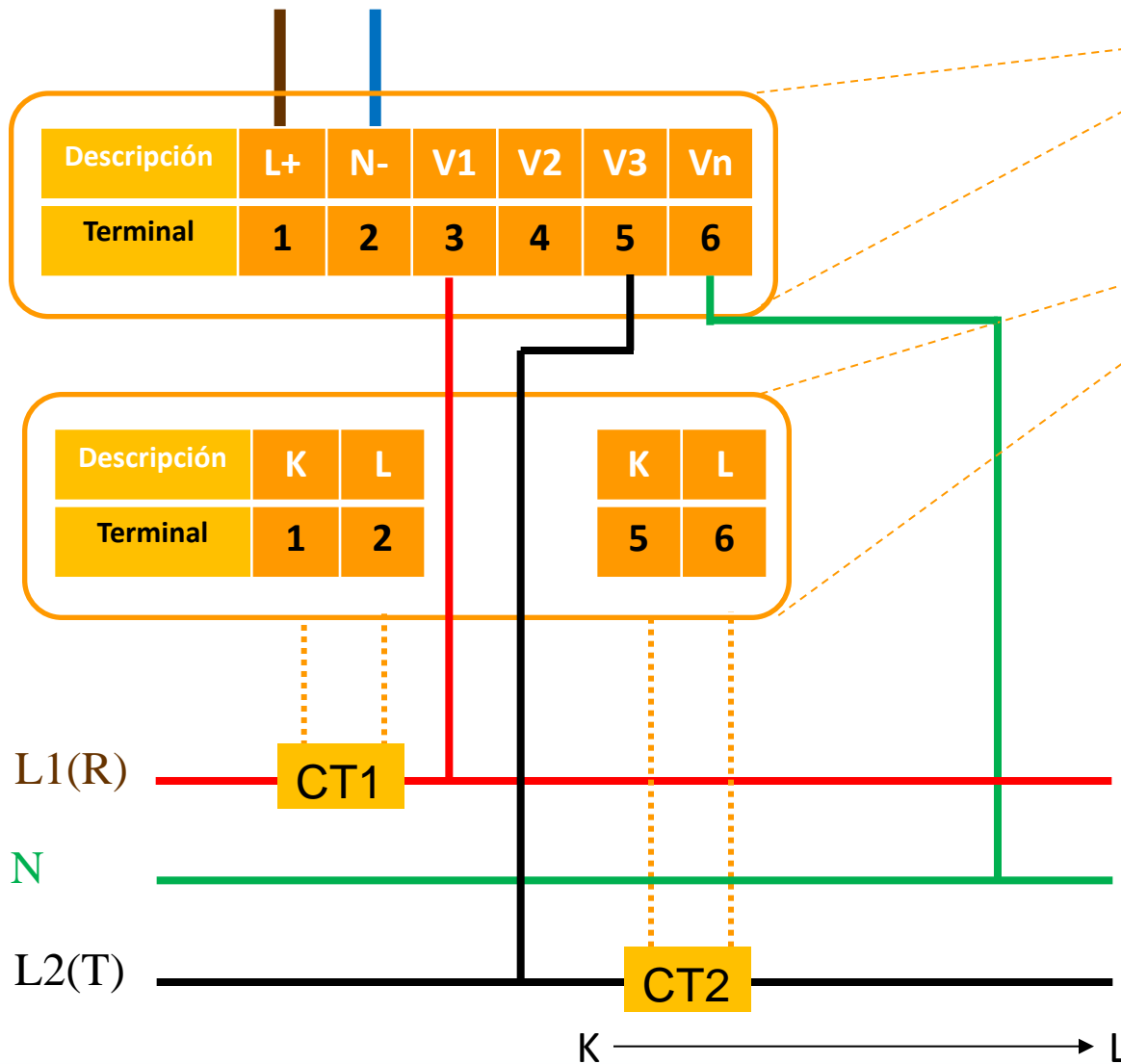

Sistemas trifásicos, 3 Hilos

Alimentación: 85-264 VCA / 100-300 VCC

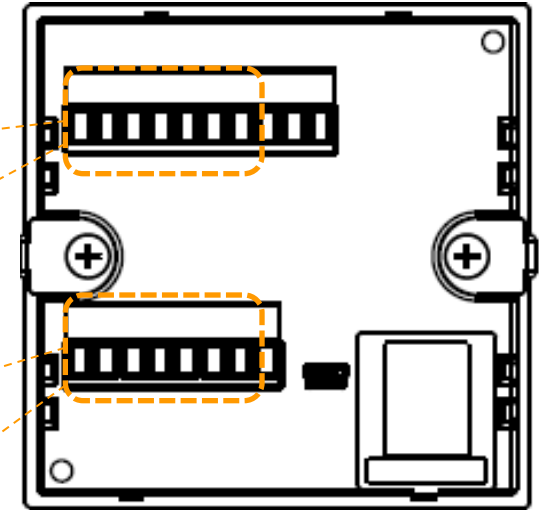
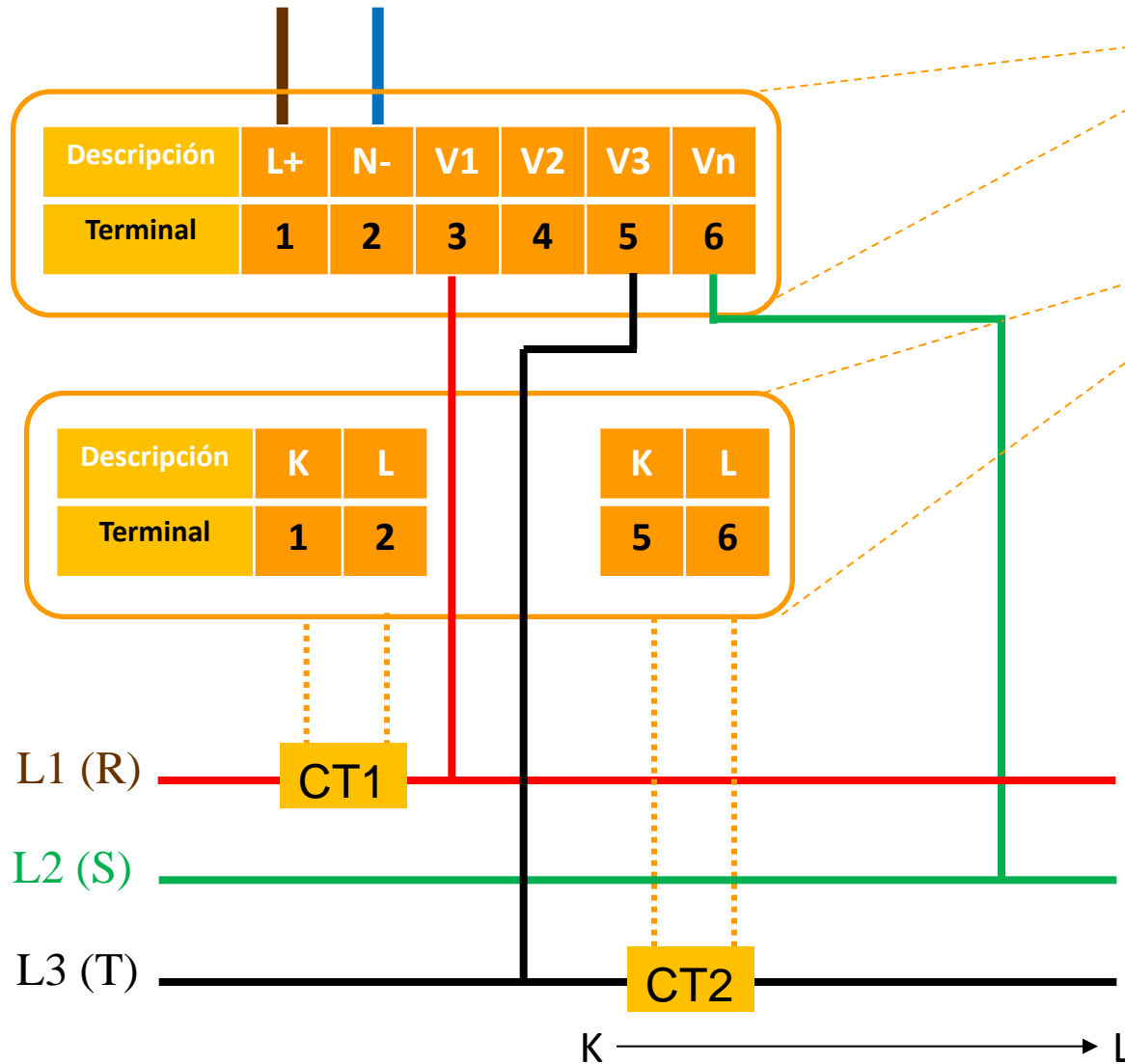

Sistemas trifásicos, 4 Hilos

Alimentación: 85-264 VCA / 100-300 VCC

