



■ Control Solutions

Industrial Power Supplies

Delta Series Power Supplies
Compact Series Power Supplies / USP
LOCC-Box – Intelligent DC Circuit Protection

Efficiency in Automation

Cable • Connectivity • Cabinet • Control

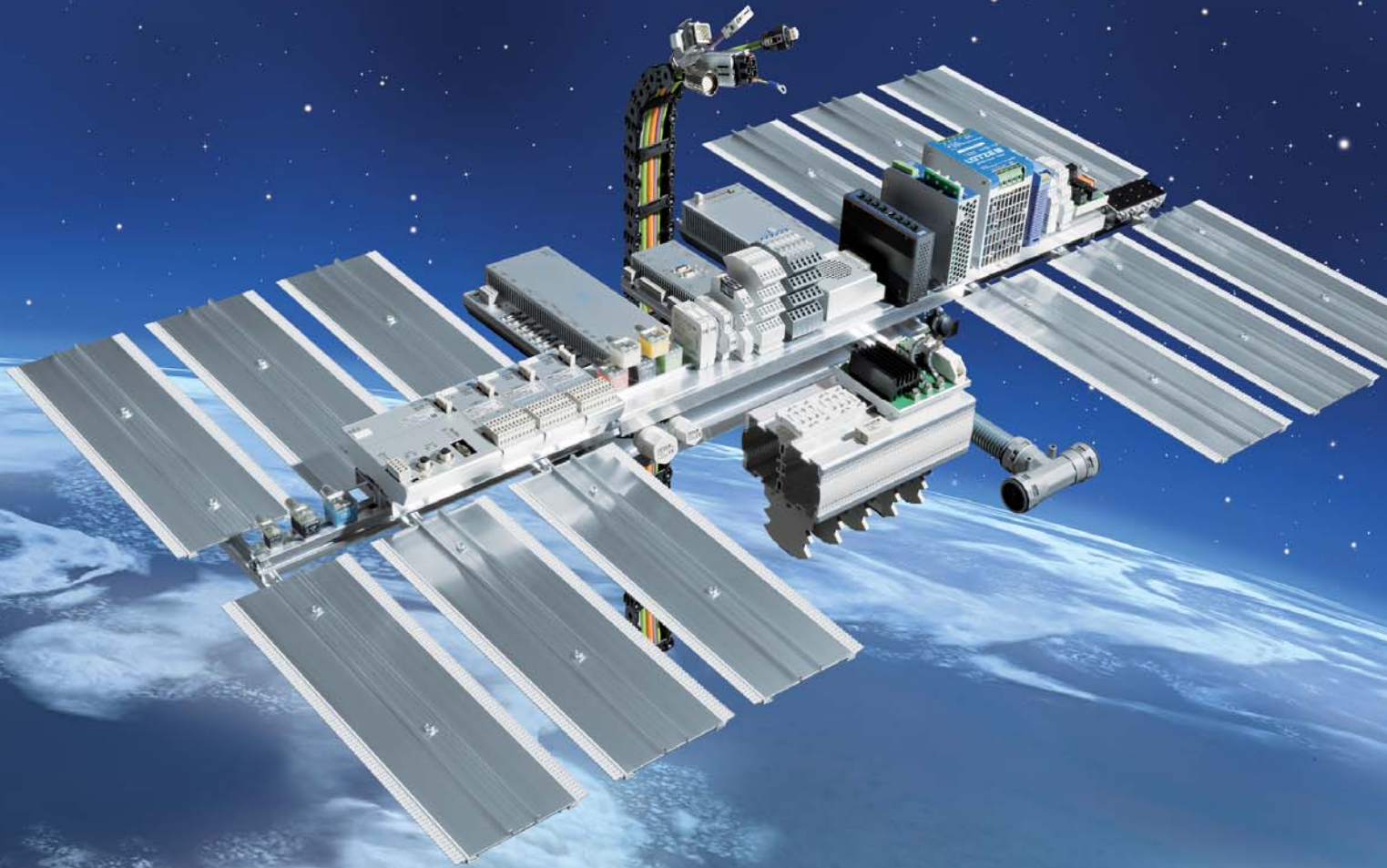

Welcome to LÜTZE

Cable Solutions



Efficiency in Automation - A reflection of our company philosophy

As an experienced specialist in automation technology, with solutions for flexible and high flexing cables, cable assemblies, interfaces, current control and cabinet wiring, we have had a focus on efficiency for many years.

Connectivity Solutions



LÜTZE defines Efficiency in Automation field as the use of sustainable products and solutions to further increase the performance of our products in our customers applications.

We realise this by using components for highly efficient control systems, products with above average life cycles and raising energy efficiency in control cabinets by means of the LSC wiring system.

Cabinet Solutions



Efficiency in Automation reflects our efforts in striving for efficient working relationships with our customers: in a medium sized family owned company we have short communication channels and a high level of manufacturing competence.

The value of a product or a solution from LÜTZE is determined by its sustainable qualities. Every innovation will only be successful in the future if it has a long term positive effect. Therefore, we provide long lasting as well as highly efficient components.

Control Solutions



Thus LÜTZE creates value through efficiency. LÜTZE provides answers and demonstrates how to handle resources responsibly, with our environment and our future in mind. **LÜTZE - Efficiency in Automation**

For more information on our solutions, please visit www.luetze.com or www.lutze.com

Transportation Solutions





Business Management: Sustainable and forw



The future is blue

Sustainable enterprise means thinking and planning ahead, understanding and embedding the belief that long lasting success is more important than short-term profit maximisation.

This is an attitude that has existed within LÜTZE for quite some time. Economic and environmental responsibilities complement each other well and are reflected in the sustainable management and

product policy - and from now in the **SkyBLUE** campaign.

We manufacture our products in a resourceful and energy-conscious manner. We use long lasting, environmentally-friendly materials.

And our products, in turn, help our customers save energy and resources.

Good for everyone: for us, for the environment, for our customers a win-win-win situation.

ard-looking

„The competitiveness of our industry and of its suppliers depends quite substantially on how we succeed in developing practical results. The results that we produce together today, are our competitive advantages in the future.“

*Udo Lütze,
Member of the Executive Committee of
the Green Carbody Innovation Alliance*



Goods with real value

The value of a product or a solution from LÜTZE is determined by its sustainable qualities as well. Every innovation is only as successful in the future if it has a long-term positive effect. Therefore, we provide long lasting as well as highly efficient components.

We are incorporating the necessary knowledge and manufacturing competence in numerous joint projects with the objective of improving energy efficiency and

sustainable technologies and industries. Thus, LÜTZE provides answers and demonstrates how to handle resources responsibly, with our environment and our future in mind.



RoHS

Power Supplies from LÜTZ

Energy efficient and space s

**Comprehensive range
of industrial power supplies**

High efficiency
through advanced digital technology
Efficiency up to >94 %

Extremely compact

Power Boost

**Power range
from 10 W up to 2400 W**

**Output voltages
from DC 5 V up to DC 72 V.**



E:
aving



Power Supplies · Product Overview

LCOS-PS Page 19



120 W

DELTA Series Page 22



1-phase, 10 W



1-phase, 30 W



1-phase, 120 W

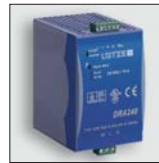

1-phase, 240 W



1-phase, 480 W



3-phase, 960 W

COMPACT Series Page 42



1-phase, 70 W



1-phase, 120 W



1-phase, 480 W



50A Redundant Module



3-phase, 2400 W



DC USV

LOCC-Box Load Monitoring Page 64



Standard
DC 1 A - DC 10 A



Gateway
CANopen



Gateway
ProfiNet



Gateway
Profibus



Supply Terminal



0V Collective
Terminal

LCOS-CC Load Monitoring Page 88



120 W

Varioprint Protection Modules Page 96



Fuse modules

Microcompact DC/DC Converter Page 97



DC/DC Converter

Power Supplies · Basics

A power supply has a decisive influence on the availability and operational reliability of electrical systems.

Consequently, the selection of the right power supply should be just as critically and carefully undertaken as that of the other system components.

1. General structure

Regardless of the technology employed, power supplies are devices with an input side and an isolated output side.

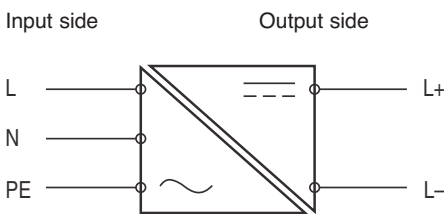

In technology terms, however, there are two different basic designs:

Unregulated and regulated.

The regulated variants are subdivided into linear-regulated and switched-mode power supplies.

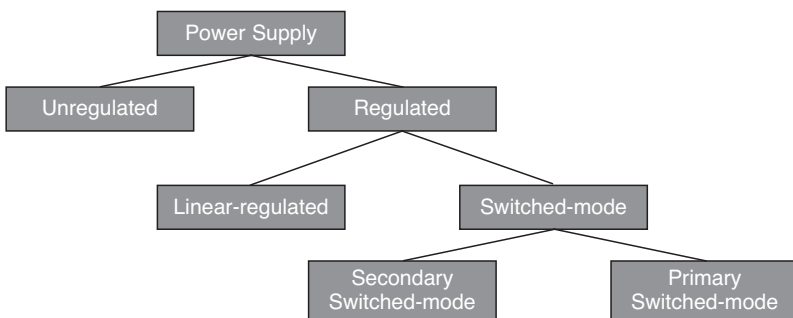

The key criteria in selection of a power supply are:

Input side:

- Input voltage
- Primary grounding
- Current consumption
- Inrush current
- Input fuse
- Frequency
- DC supply
- Power failure buffering
- Power Factor Correction (PFC)

Output side:

- Output voltage
- Secondary grounding
- Short-circuit current
- Residual ripple
- Output characteristics
- Output current

2. Safety

The safety of people and equipment is always the priority. Accordingly, power supplies must comply with unified regulations and standards.

2.1 Galvanic isolation

Galvanic isolation generally refers to the isolation between two conductive objects, such as metal plates or electrical circuits. In the case of electrical circuits it is consequently not possible for charge carriers to flow from one circuit into another, as there is no electrically conductive connection between the two.

In the case of power supplies this means that there is no electrical connection between the input and output sides.

2.2 Insulation

The different kinds of insulation are specified in IEC/EN 60950:

- Functional insulation
Insulation needed for the correct operation of the equipment.

- Basic insulation
Insulation to provide basic protection against hazardous structure-borne currents.
- Supplementary insulation
Protection against hazardous structure-borne currents if the basic insulation fails.
- Double insulation
Insulation comprising both basic insulation and supplementary insulation.
- Reinforced insulation
Unified insulation system. Provides equivalent protection to double insulation.

2.3 Safe isolation

Safe isolation according to EN 50178 is required for all interfaces between different electrical circuits, such as between a SELV circuit and a mains circuit.

Safe isolation means that no current flow can occur from one electrical circuit to another. This isolation has to be implemented either by double or reinforced insulation or by means of protective shielding.

2.4 Secondary grounding

In case of secondary grounding, the output side of the power supply is connected to protective earth (PE) in order to prevent dangerous ground faults.

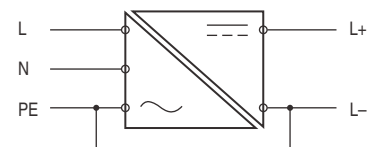

Secondary grounding

A ground fault occurs if a current-carrying line has contact to earth. In the worst case, two simultaneous ground faults can lead to a bridging of switches and thus can start equipment accidentally.

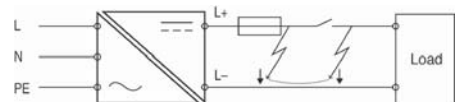

Ground fault

If secondary grounding is used, the occurrence of such a ground fault leads to a so-called short circuit to earth which causes the fuses in the secondary circuit to trip.

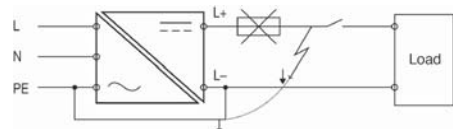

Power Supplies · Basics

2.5 SELV

SELV according to IEC/EN 60950 is a safety extra low voltage which thanks to its low level and insulation offers better protection against electric shock than higher-tension circuits.

Power supplies generating SELV, for example, must be designed to prevent shorting between the primary and secondary windings and their connections. The windings can only be overlaid if double or reinforced insulation is placed between them. This isolation is termed galvanic isolation. Grounding of the secondary side is not required but permitted.

The peak value must not exceed 42.4 V in case of AC voltages and 60 V in case of DC voltages.

2.6 PELV

PELV according to IEC/EN 60950 is a protective extra low voltage with safe isolation. In case of PELV, the electrical circuits are grounded and (like SELV) safely isolated from circuits of higher voltages. The voltage limits are identical to SELV.

PELV is used where active low-voltage conductors or the equipment structures have to be grounded for operational reasons. That is the case, for example, where potential equalisation is required to prevent sparking inside vessels and explosive rooms.

Thanks to the housing earth, hazardous leakage currents can be discharged via the structure independently of the low voltage when interference occurs on other equipment whose touchable conductive parts receive mains voltage.

2.7 Protection class

The standard IEC/EN 61140 defines protection classes for electrical equipment. The devices are classified according to the safety measures taken to prevent electric shock. The protection classes are divided into the classes 0, I, II and III.

• Protection class 0

Apart from the basic insulation there is no protection against electric shock. These devices cannot be connected to electrical installations with PE. Equipment of class 0 is not allowed in Germany. Protection class 0 will no longer be considered in future versions of the standard.

• Protection class I



In addition to the basic insulation, all electrically conductive parts of the housing are connected to PE. This guarantees that no electric shock can occur in the event of an insulation failure.

• Protection class II



Protection against electric shock is not only based on the basic insulation. The housing is equipped with reinforced or double insulation. If the housing is made of electrically conductive material, no direct contact between the housing and current-carrying parts is possible. The housings of class II devices are not equipped with a PE connection. It is important to note that the PE connection is not only used for the grounding of housings but also to connect filters for EMC measures (electromagnetic compatibility) to ground. This is why even devices of which the housings are completely made of plastic material can be equipped with a PE connection.

• Protection class III



The device is operated with safety extra-low voltage (SELV) and thus does not require any protection measures. Power supplies are usually class I or II equipment.

2.8 Degree of protection

According to DIN EN 60529, electrical equipment is classified using so-called IP codes. IP stands for "International Protection" or "Ingress Protection". The IP code consists of two figures: The first digit specifies the protection against accidental contact and against ingress of solid foreign bodies; the second digit specifies the protection against ingress of water.

Since power supplies are mostly installed inside cabinets, their typical degree of protection is IP 20.

3 Input voltage ranges

3.1 Wide-range input

Wide-range input means that the device can be operated with any voltage within the specified limits. Lütze devices operate in the single-phase range from AC 90V to AC 264V or DC 110V to DC 370V and in the three-phase range from AC 340V to AC 576V or DC 480V to DC 820V. There is no loss of power, i.e. the device is able to deliver the specified rated power over the entire input voltage range.

3.2 Autorange

Power supplies that are equipped with autorange behaviour perform an internal measurement of the applied supply voltage and automatically switch between the available input voltage ranges.

3.3 Manual range selection

In case of manual range selection, the housing of the device is equipped with a selector switch for manual input voltage range selection. Lütze offers devices permitting operation at AC 115V or 230V.

The operating voltage range is then AC 90 V to AC 132 V; AC 185 V to AC 264 V or DC 300 V to DC 370 V.

4 Self-protection

If motors or other large loads have to be started with high inrush currents, secondary branches selectively switched off, systems moved to a safe state in case of overload or the power supply switched off as quickly as possible in case of fault for the sake of process safety, the output behaviour of the power supplies play a key role.

There are basically two types outside of nominal operation. Overload, which can occur sporadically or continuously, and short-circuit.

Overload means that the current required by the loads exceeds the nominal current of the power supply.

A short-circuit is a special form of overload. In this case, the outputs of the power supply are interconnected at very low resistance, as a result of which the output current may assume extremely high values.

State-of-the-art Lütze power supplies offer the following protective functions:

Fold-back characteristic/Hiccup mode

Lütze power supplies supply a current typically up to 1.2 times the nominal output current. They automatically switch off if the current consumption of the connected loads exceeds this value or if a short-circuit occurs. After a defined period of time, the power supply tries to restart the load. If the overload or the short-circuit still exists, it switches off again. This procedure repeats until the fault is cleared. The power supply has "hiccups". In applications requiring high starting currents, it must be ensured that the overload current capacity is higher than $1.2 I_N$. To do so, Lütze also offers devices with overload capacity of $1.5 I_N$ featuring Hiccup mode. Another aspect is response to short-circuit. The output voltage is cut very rapidly. Whereas the use of conventional line protection equipment in the secondary circuit is very critical in any case, the function under Hiccup mode is not. Electronic overload protection units such as the Lütze LOCC-Box should always be used in such cases. They provide safe protection in all circumstances.

Power Supplies · Basics

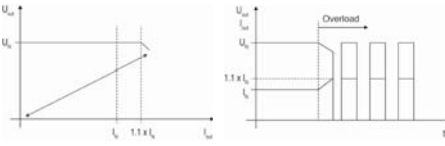

U/I characteristic

Lütze power supplies with a U/I characteristic perform current limiting to typically 1.2 times the nominal current at constant output voltage. This current is still available in case of an overload or a short circuit. The voltage is slowly lowered, while the output current may rise further (triangular current limiting). Since the current does not sag in case of an overload, this method enables reliable starting of high loads.

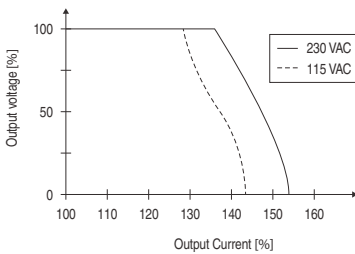

5 Influence of ambient temperature

The ambient temperature has a direct influence on the maximum possible output power of a power supply and so on its response to short-circuit or overload. Temperatures inside cabinets may be over 60 °C as a result of internal or external influences. Power supplies still have to operate reliably even at such high temperatures. Due to the components used, however, there is a point as from which the output power has to be reduced. That point is described by so-called derating. The Delta series from Lütze is rated for ambient temperatures up to 70°C for example, with derating beginning at 60°C. The reduction in output power is 2.5%/°C.

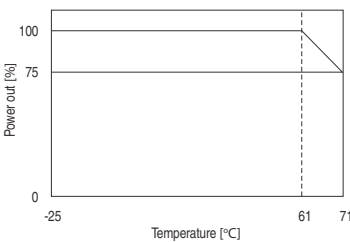

Example: Derating curve of Lütze of Delta series

6 Thermal protection

When operating a power supply under extreme conditions for a long duration, e.g. in case of permanent operation within the power limits or in case of very high ambient temperatures, the power supply can heat

up to a degree where safe operation is no longer guaranteed. There are a number of techniques for protecting the power supply against destruction due to overheating.

- The maximum output power is reduced, allowing the power supply to cool down.
- The device is switched off completely and cannot resume operation until a manual reset is performed. Depending on the manufacturer, the reset is done either using a corresponding switch or by disconnecting the supply voltage.
- The device only switches off the output and does not switch it on until the temperature falls below a certain limit value. This is the most frequently used method nowadays, and is the one used by LÜTZE.

7 General parameters

7.1 Open circuit resistance

Open circuit resistant power supplies require no minimum load in order to provide a stable output voltage. This is important, for example, in the case of time-critical applications in which a load is applied which has to be immediately supplied with voltage. Power supplies which are not open circuit resistant often require up to the seconds range until an actual supply takes place.

7.2 Resistance to reverse feed

The resistance to reverse feed specifies up to which voltage a power supply is immune against the feeding of voltages into the secondary side. Such a current flow can occur if power supplies are operated in parallel or inductive consumers are connected.

7.3 Overvoltage protection (secondary side)

In case of an internal error of the power supply, this protection mechanism prevents the occurrence of overvoltage on the secondary side that could possibly damage or even destroy a connected load or exceed the SELV voltage limit.

7.4 Power failure buffering

Power supplies must be able to maintain their output voltage for a certain time in case of supply voltage dips. Usually, a power failure buffering time of at least 20 ms is aspired in order to provide buffering for one complete cycle of the mains voltage. In the semiconductor industry longer time are required. The devices must then comply with the requirements of SEM F47. Most LÜTZE devices do so.

8 Line cross-section and protection

8.1 Input-side protection

If power supplies have their own input protection, such as a safety fuse, no further protective measures are necessary. However, standards stipulate that a power supply must be capable of being disconnected from the supply mains by external means. Line protection equipment can then be used. For the relevant characteristics refer to the LÜTZE data sheets.

8.2 Output-side protection

Alongside the output behaviour described in section 4, there is a U/I characteristic with an additional power reserve. However, all these output behaviour modes are ultimately not suitable for safe activation of standard line protection equipment. The reason lies in the technical design of the equipment. Only electronic protection devices capable of reacting fast enough to overload or short-circuit offer a solution. These devices also feature a high degree of repeat accuracy across the entire temperature range. With the LOCCBox LÜTZE offers intelligent DC protection modules which can also be integrated into field bus communications systems. (See also Electronic overload protection, page).

8.3 Selectivity

Selectivity means the tripping coordination. In electrical systems, distinction can be made between "series selectivity", which means that individual fuses connected in series are selective against each other, and "parallel selectivity", which means that electrical circuits connected in parallel are selective against each other.

Series selectivity

In case of series-connected fuses, the tripping coordination of fuses is considered as selective if only the fuse installed nearest to the fault trips. Fuses that are located nearer to the energy feeding point do not trip. This guarantees that as many system parts as possible remain operative in the event of one single fault, resulting in an increased availability of electrical systems.

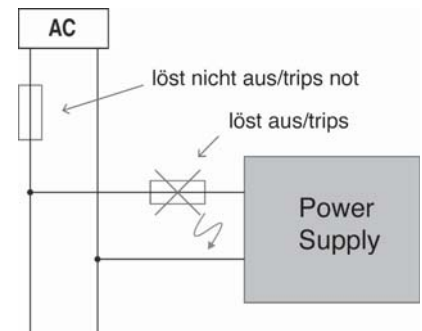

Rule of thumb:

The fuses must differ by two nominal quantities

Power Supplies · Basics

Parallel selectivity

Based on the self-protection, the output voltage is switched off or reduced in the event of a fault. If multiple loads are carried on one power supply, a voltage drop will occur throughout the entire application. To prevent this, protective devices are installed in the individual lines to the consumers. If a fault occurs, the protective device concerned must trip fast enough so as to disconnect the faulty consumer reliably from the rest of the system and such that the other consumers remain available.

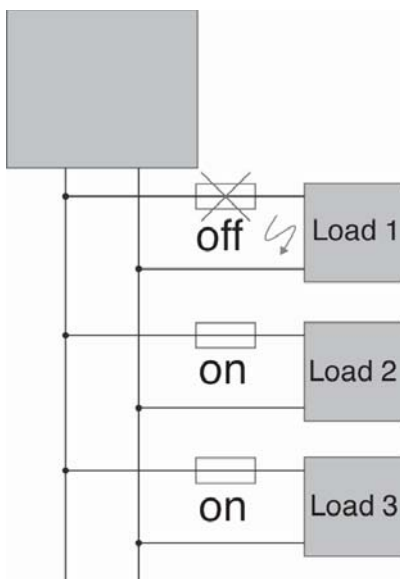

8.4 Connection cross-sections

The line cross-sections are selected dependent on the maximum output current. The following table provides an overview of the current capacities of multi-core moveable copper cables with different conductor cross-sections at a temperature of 30 °C and up to a nominal voltage of 1000 V (to DIN 57100-523).

Cross-section in mm ²	A
0.75	12
1	15
1.5	18
2.5	26
4	34
6	44
10	61

9 PFC (Power Factor Correction)

Since 1 January 2001, the European standard regarding the limits for harmonic current emissions (IEC/EN 61000-3-2) is in force. This standard defines the maximum allowed intensity of harmonic currents fed back into the supplying mains system. It is applicable for consuming devices with an active power input between 75 and 100 W that are directly connected to the public electricity supply. Power supplies for industrial applications often do not require PFC, since large installations are equipped with a central PFC, installed between the internal electrical system and the public electricity supply.

9.1 Passive PFC

For passive PFC, a reactance coil is connected to the input circuit. This reactance coil buffers energy from the mains and thus reduces the current pulses. The lower the pulses, the less harmonics are produced. The advantage of this solution is its easy implementation into existing circuitry. However, the drawback is that it is not able to reduce all harmonics.

9.2 Active PFC

Active PFC is able to deliver considerably better results. In a very simplified consideration, one could say that the actual power supply is preceded by another power supply that performs a regulation of the current consumption from the mains. This consumption is oriented towards the sinusoidal supply voltage. Using this technology, it is possible to avoid the production of almost every kind of harmonics. However, the circuitry is much more complex than for passive PFC. LÜTZE power supplies are all equipped with active PFC.

10 Applications

10.1 Parallel connection of power supplies for increased capacity Operation

An increase of the output power can be obtained by connecting power supplies in parallel. This can be necessary if the current required by the load is higher than a single power supply can deliver, for example after the expansion of an existing installation. The following preconditions must be met when connecting power supplies in parallel for the purpose of increased capacity:

- Parallel connection is only allowed for identical power supplies.
- The power supplies have to be switched on simultaneously.
- The following points must be observed when connecting the power supplies in order to prevent different voltage drops on the supply lines or at the terminals which would lead to unbalanced load at the common connection point:

- Identical lengths of the supply lines
- Identical conductor cross-sections of the supply lines
- Terminal screws have to be fastened with the same torque to guarantee equal contact resistances.
- The output voltages of the power supplies should not differ by more than 50 mV in the open circuit state. Otherwise safe operation cannot be guaranteed.

10.2 Redundancy

The term redundancy generally denotes the existence of several objects that are identical in functionality, content or nature. In industrial automation, redundancy ensures that in the event of failure of a power supply another one takes over the supply, thereby maintaining operation of the system. For this the individual power supplies must be isolated from each other, as one faulty power supply might impact on the other one. In the worst case the failed power supply effects a secondary-side short-circuit, which would result in failure of the second power supply. To isolate the power supplies from each other, isolating diodes (so-called O-ring diodes) must be looped into the secondary outputs of the power supplies. They then prevent reciprocal loading. This ensures uninterrupted power supply. In the LÜTZE Delta series the isolating diodes are built-in to the output. In the Compact series the diodes must be installed externally as follows:

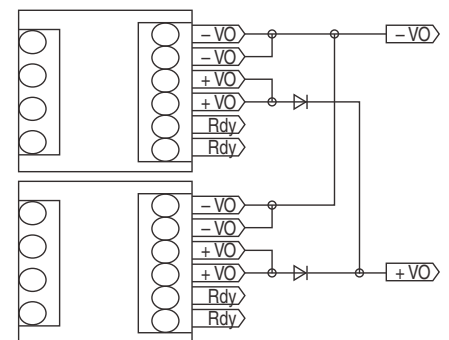

LÜTZE offers isolating diodes up to a nominal current of DC20A.

Current Control System · Basics

Reliable protection of DC 24V circuits

Intelligent safeguarding of selectivity

Primary switching controllers and automatic power units nowadays form the basis of the DC 24V supply level. Due to the operating behaviour of those devices, the specified selective protection of individual circuits, especially in case of overcurrent, is virtually unfeasible. A complete system shutdown is inevitable.

Operating behaviour of primary switching controllers

Switched-mode power supplies and their components are rated for a specific nominal value and run hot under higher load. To protect against self-destructing, they shut down at between 1.1 and 2.5 times the nominal current, according to type. Many devices feature Hiccup mode, which switches off in case of overload and automatically switches back on after a short time. If the overload persists, the process repeats until the fault is manually rectified. This means a fuse is never tripped. Using devices with a forward characteristic does not deliver success either. The power supply does not switch off, but supplies only a 1.1 to 1.2 times higher output current when the output voltage is reduced. This characteristic likewise does not trip an automatic circuit-breaker, or if it does, then only in the hours range. Furthermore, both output modes have the disadvantage that loads such as DC motors or capacitive consumers cannot be started. At additional cost, operation of heavy loads can be achieved in the simplest case by using a device with a higher output power or a device with integrated power boost.

In this, the device with power boost continuously supplies 1.2 to 1.3 times the nominal current in the temperature range up to +45°C. On reducing the output voltage, a maximum of 2.5 times the nominal current is reached which - dependent on the device itself and the characteristic of the automatic circuit-breaker - may be just enough to effect a shutdown.

Characteristics of automatic circuit-breakers

The trip curve of an automatic circuit-breaker with characteristic B (Figure 1) is considered by way of example. To record smaller overcurrents, a thermal trip in the minutes to hours range is used (hold >1h at $I = 1.13 \times I_{nom}$ and trip <1h at $I = 1.45 \times I_{nom}$). Switch-off in case of high overcurrents is effected by immediate magnetic tripping within 0.01 to 0.1 seconds. If such a device is used in conjunction with a 10A switched-mode power supply, the switch-off occurs at 1.2 times the nominal current only after 20 to 60 minutes. Even at 2.5 times nominal current (power boost) between 25 seconds and two minutes elapse until switch-off in the thermal range. In short: essential protection - in particular selective protection of connected devices - is not provided. The fuse essentially performs a dummy function. In the event of a short-circuit or faulty wire supply would be maintained at 2.5 times nominal current. System failure or even a cable fire may be the consequence.

Selective switch-off

Selective load protection means that in case of overload or short-circuit only the faulty current path is switched off, with no reactive effect on the supply. The standards EN60204-1 (line protection and fire prevention) and EN 61131-1 and -2 (operating states and storage) are also applicable to the rating of the overcurrent protection device in DC 24V circuits. In concrete terms, this means withstanding a mains power failure lasting 10ms without functional impairment, which demands the deployment of large input capacities. Furthermore, hazardous overcurrents must be reduced to a safe level within 5s. Rating is made more difficult by the fact that nowadays many parallel consumers are supplied by way of one protection element.

LÜTZE LOCC-Box – the intelligent current monitoring system



Figure 2: LOCC-Box single module

The ideal solution would be one which is capable of optimally operating capacitive loads to start heavy loads and quickly detecting an overcurrent in operation and switching off only the affected path. Such a system should of course store the fault so as to prevent danger from switching back on and permit diagnosis. The Lütze LOCC-Box system meets those requirements in a modular design with additional intelligent functions. To meet the widely varying demands on switch-off response, the LOCC-Box system features the facility to program 10 different characteristics by way of a switch. Both standard automatic unit characteristics and in particular custom characteristics can be implemented. The nominal current range can additionally be selected with locking settings from 1A to 10A. The adjustable current range and characteristic is very important when retrofitting, as in such cases the device protection often has to be modified and adapted. As additional information, the capacity utilisation of the path is indicated by an LED. When 90% of the programmed current value is reached the status LED starts to flash. In the event of a switch-off due to overcurrent or short-circuit, in addition to the visual indication by a red LED.

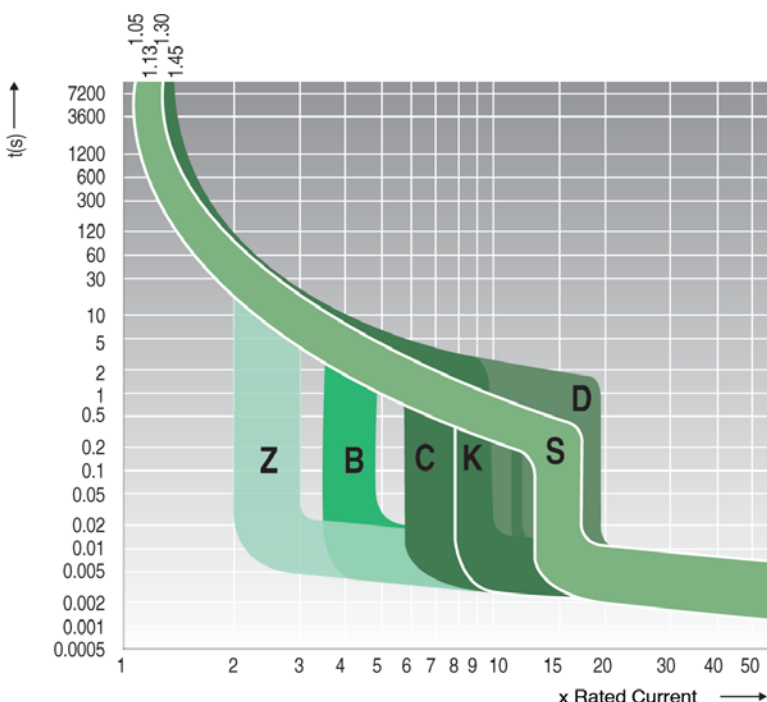

Current Control System · Basics

A 24V signal is set as a collective fault warning. This eliminates the need to install and wire additional auxiliary contacts. A restart after clearing the fault is then effected either using the mechanical switch on the device or from the main system by remote control. This channel-based switching facility is of great importance in particular in the commissioning phase of a system, as it enables individual system components to be activated and checked specifically.

LOCC-Box Practical and efficient

The monitoring function itself is one side of the coin. The other in many other systems is the associated mechanism. Frequently multi-channel solutions are offered on the market which only make sense if exactly the

available channels are required. If that is not the case, or if only one channel has to be additionally implemented subsequently, money and space will be wasted. Another disadvantage of this solution is the looping of up to 40A via a printed circuit board. This entails an enormous load on the carrier material and interruption of the entire supply when a device is replaced. What in other areas of automation has been state of the art for over 10 years is also ideal here as the solution in a highly modular configuration!

Here, too, the LOCC-Box system is setting new standards. The single-channel design with all the functionality described offers the highest possible flexibility. As shown below, customers can decide whether the supply is provided by each module individually or via the system supply (infeed terminal, copper

rail, end terminal). The particular advantage of this method of infeed is the screwless contact carriage, which permits exchanging of individual channels in operation without interrupting the entire supply. This additional provides functionality to switch off individual paths to perform essential work safely. The maximum supply current is dictated by the 6mm² terminal, and is DC 40A. The slim width of just 8.1mm results in an installed width of just 340mm even with a 40-channel configuration. The system housing is complemented by name plate labels, seals and a jumper system to loop signals.

Standard Application

without supply set, art. no. 716425 with supply set, art. no. 716425

Empty housing as placeholder

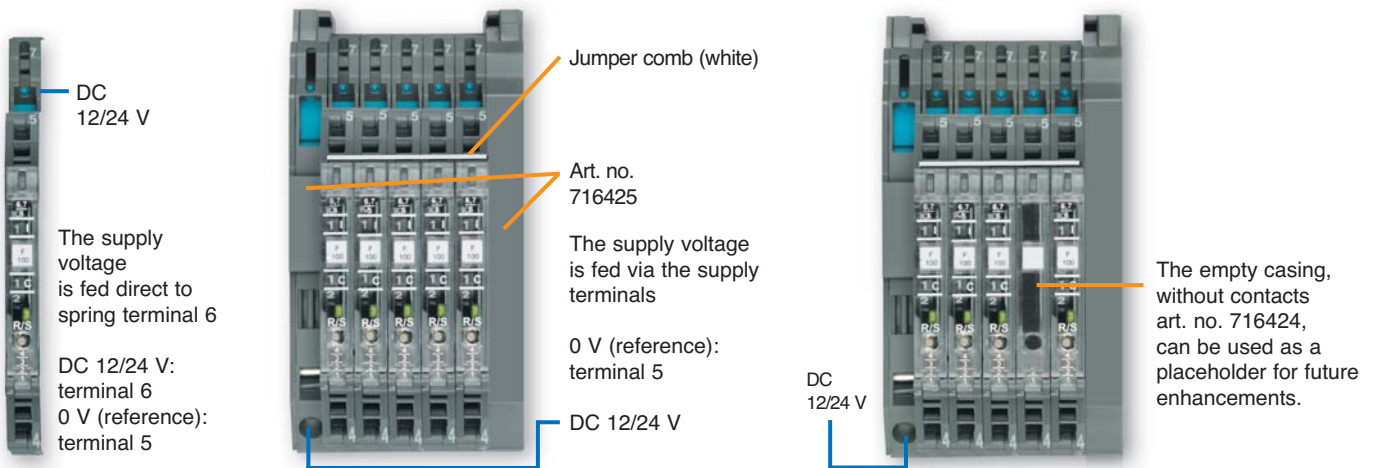

Use with additional supply terminals

Supply set, art. no. 716425 and supply terminal, art. no. 716421

The supply terminal is accessed via an aperture in the left hand side wall. This enables a variable positioning in the system construction. The maximum total current can thus be increased. Max. 160 A / 4 feeds.

Individual construction with distance terminal

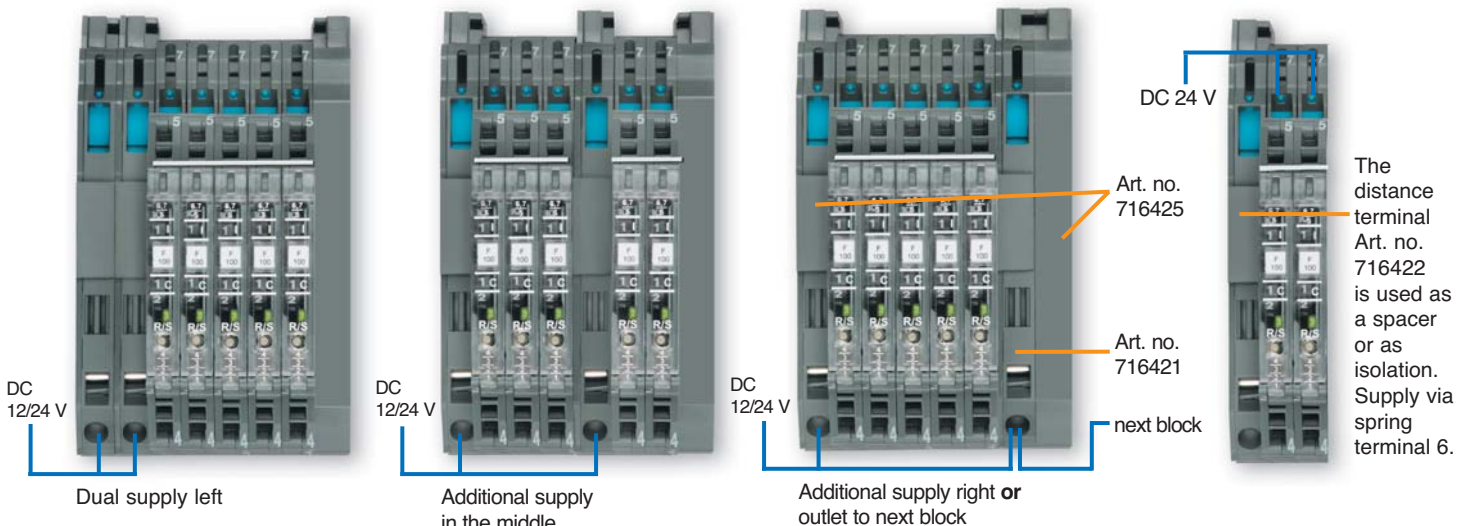

LCOS-CC • Application examples

e.g. Switching power supply 722814

DC 24 V, 100 A.

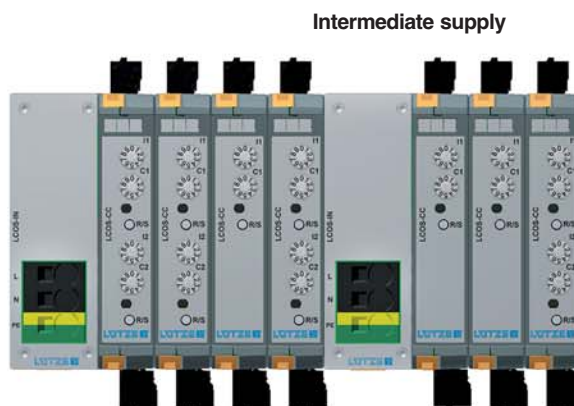
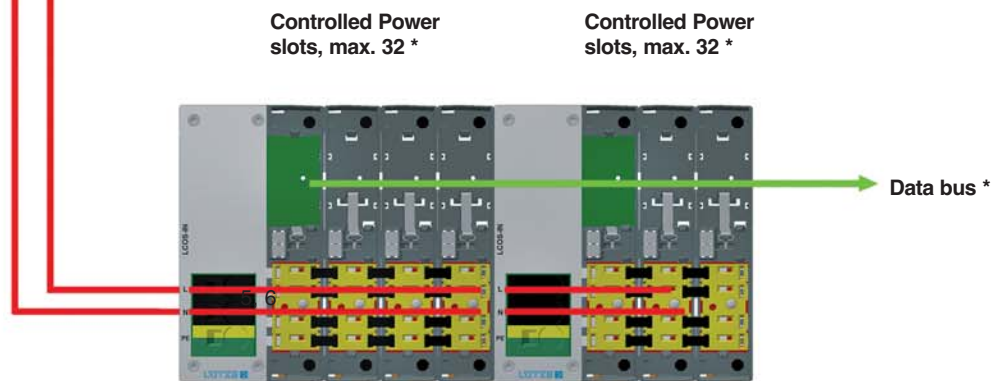

*Option with fieldbus – Design on request.

LOCC-Box / LOCC-Box-Net • Application examples

e.g. Switching power supply 722814

DC 24 V, 100 A.



Standard Application

with supply set, art. no. 716425

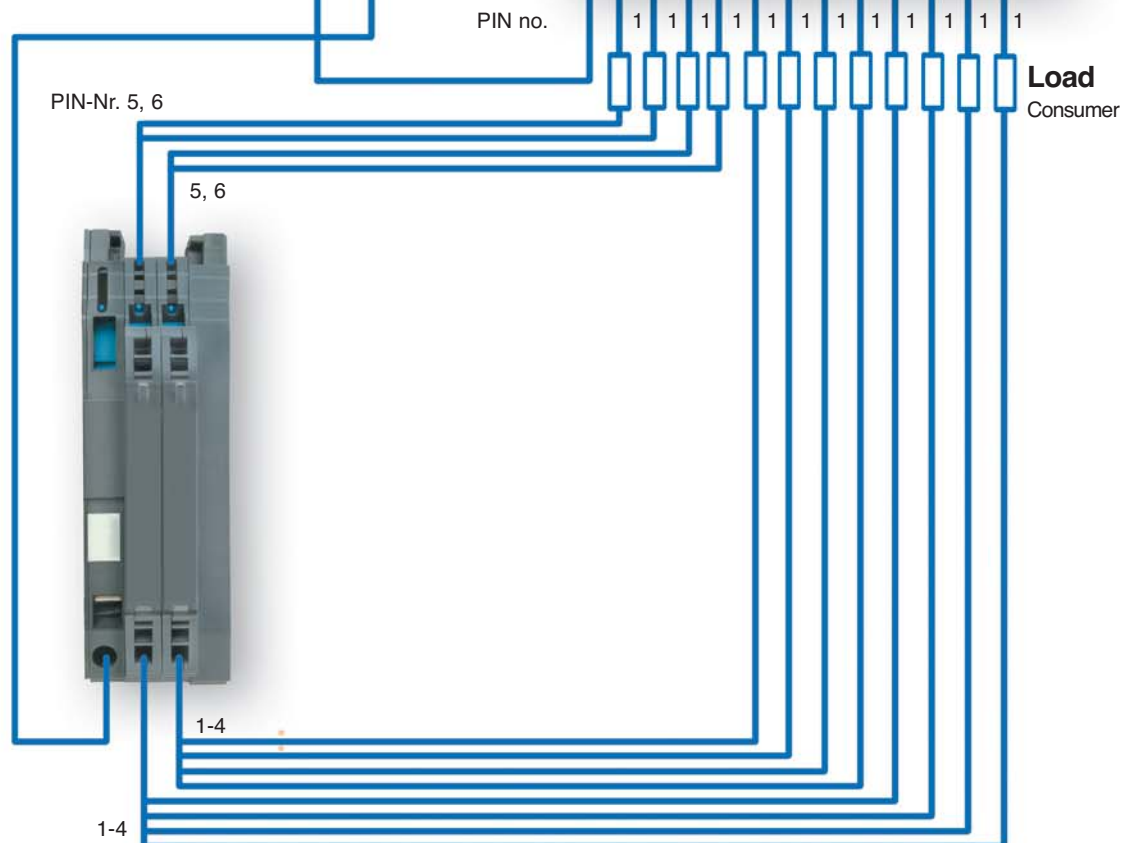
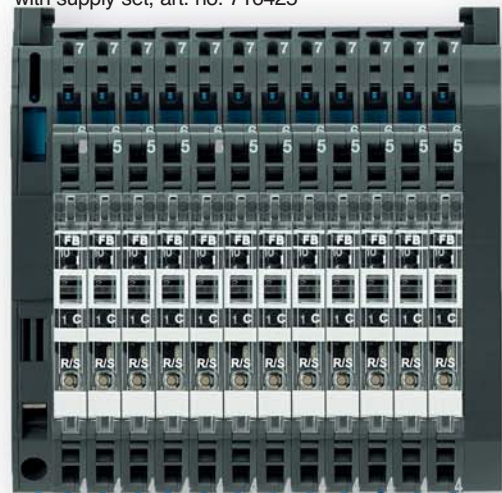

Construction of the 0 V Collective terminal

with supply set
Art. no. 716425

Lots of new application fields and unique technical features:

The new LCOS-PS Ultracompact switching power supply units

LCOS-PS120 Ultracompact 120W DIN Rail switching power supply units

This switching power supply unit line not only allows standard mounting, but also direct use in the modular LÜTZE housing system LCOS. This range opens up lots of new possibilities that are also complemented with unique technical features:

Extremely compact: 35 x 100 x 110 mm

Very high efficiency: > 93 %

Improved overvoltage protection

Simple parallel operation via downslope characteristic curve

Power unit output can be switched via a remote channel

Fault alarm output

Power boost 150 %

Energy bus (optional)

Active PFC

-25 °C bis +50 °C without derating: maximum temperature 70°C

Optional:

- Analogue output 0-10 V or 4-20 mA equivalent around output current
- Internal data bus for operation within the modular LCOS system
- Sense connection for automatic voltage regulation

Uniform housing structure in the range from 10 W to 120 W

Screw or spring type termination, plug-in

Applications: always whenever high availability is imperative:

Machine and plant construction, process and system engineering, telecommunications, renewable energies

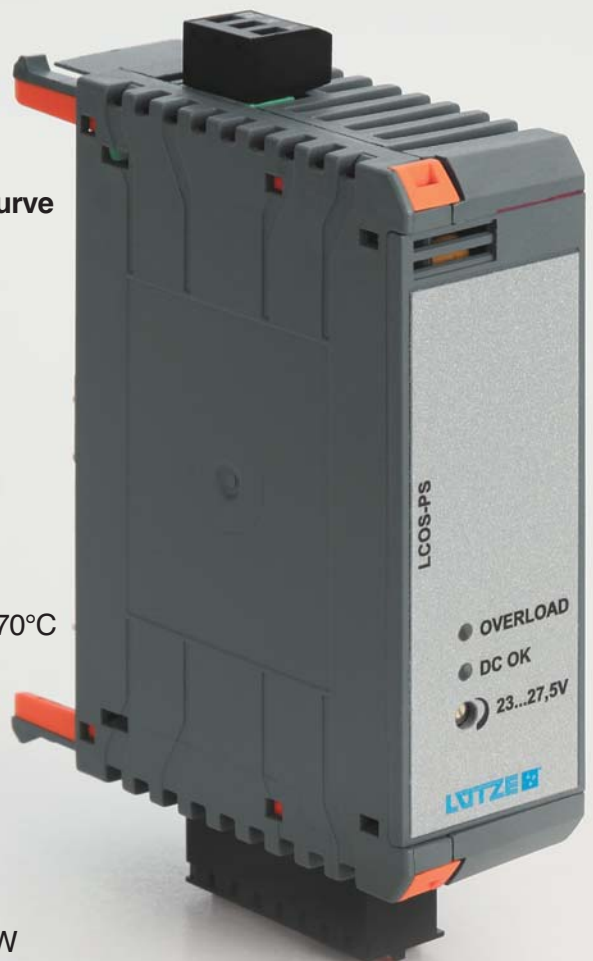

Power supply · LCOS-PS controlled, 120 Watt

Primary switchmode power supply, PFC, Single-phase
Input: Wide range input AC 88 - 264 V
Output: 24 V, adjustable



Dimensions

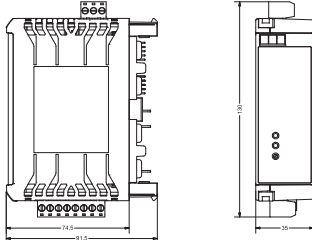

PIN assignment

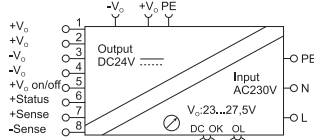

Derating

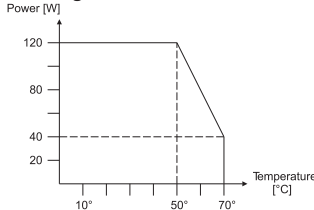

Parallel/redundant mode

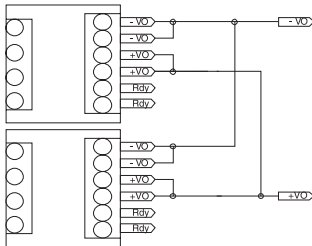

Description	Part-No.	Type	PU	
Screw terminal				
Output voltage/current	DC 24 V; 5 A	779001.1413	LCOS-PS-1-120-24	1
Push-In				
Output voltage/current	DC 24 V; 5 A	779101.1413	LCOS-PS-1-120-24	1
Part-No.				
	779001.1413		779101.1413	
Note				
Included in the delivery	Plug-in terminals : RM5.08 and RM 3.50, Function carrier Part-No. 780201.350.1			
Not included in the delivery	other accessories, see „accessories“			
Input				
LCOS-PS-1-120-24				
Nominal voltage	AC 100–240 V			
Operation voltage range	AC 88 V - 264 V			
Line frequency	47 – 63 Hz			
Rated current	U _I = AC 230 V: 0.70 A			
Inrush current	<AC 20 A (AC 230 V)			
Internal fuse	T4.0 A / AC 250 V			
External fuse	Mini-circuit breaker: B 6 A			
Power Factor Correction P.F.C.	>0.96			
Output				
Rated voltage output	DC 24 V			
Rated current output	5 A @ 50 °C			
Max. output current	>7,5 A, 5 s, with U _{out} >90 %			
Short-circuit current	-			
Voltage trim range	23-27,5 V			
Line regulation	0.5 %			
Load regulation	downslope -2 % at 5 A			
Rise time	< 1 S			
Ripple & Noise	≤100 mV pp			
Hold up time	>20 ms			
Status indication DC ON LED green	≥21.6 V			
Status indication DC LOW LED red	I _{out} >110 % I _N			
Parallel/redundant operation	yes / via external decoupling diode			
Efficiency	>93 %			
Low power loss	9 W @ 230 V			
Rated over load protection	yes			
Over voltage protection	-			
Short circuit characteristics	Current limited (overload), Hiccup after short circuit			
General				
Insulation voltage input/output	AC 3.0 kV _{eff}			
Insulation voltage input / ground	AC 1.5 kV _{eff}			
Insulation voltage output / ground	DC 0.5 kV _{eff}			
Operation temperature range	-25 °C – 70 °C			
Derating	>50 °C: -4 W / °C			
Storage temperature range	-25 °C – 85 °C			
M.T.B.F.	>500000 h to SN29500 / >150000 h to MIL standard HDBK 217F			
Relative humidity	20–95% RH, non-condensing			
Dimensions (w × h × d) in mm	35.0 × 100.0 × 110.0			
Cooling	Air convection			
Housing material	Polyamide PA6.6 (UL94V0, NFF12, F2)			
Field installation	rail TS 35 (EN 50022)			
Application height	2000 m			
Installation position	vertical			
Protection class	IP 20 (IEC529, EN60529)			
IP rating	I (SELV, PELV)			
Overvoltage category	II (IEC 664-1)			
Pollution degree	2			
Weight (kg/piece)	0.350			
Termination	0.2–2.5 mm ² (AWG24-12), input: 3-pin, output: 8-pin			
Approvals	UL, cUL: UL 508, IEC 60950, IEC 950 CE: EN 60950, EN 61000-6-2 (2005), EN 60100-6-4 (2007), CE: EN 61000-4-2/3/4/5/6/11, EN 61000-5-5, EN 50178, EN 61558			
Monitoring				
DC ON Control (Rdy)	Open Collector			
Switching voltage	DC 30 V			
Switching current	DC 100 mA			
Remote Eingang				
control voltage	DC 24 V			
Control current	DC 5 mA			
ON/OFF	0 V: OFF, DC 24 V: ON			
Optional				
Sense output	automatic voltage regulation			
Analogue output	0–10 V, 4–20 mA proportional to output current			
Communication interface:	LCOS-Bus			

DELTA Power Supplies



DELTA Series

- One- and three-phase
- 10 W to 960 W
- Parallel operation
- Overload and short circuit protection
- Redundant operation with integrated diodes
- High efficiency
- Protection class IP20
- UL Listed
- Class 1 Div.2, A, B, C, D, T4
- Economical

Power supply · regulated, 10 W

Primary switchmode power supply, Single-phase, Class 2
Input: wide-range input AC 90–265 V, DC 120–370 V
Output: 5 V / 12 V, adjustable



Dimensions

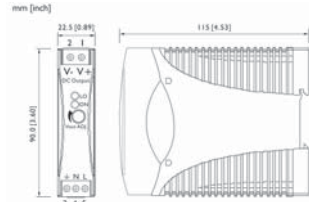

PIN assignment

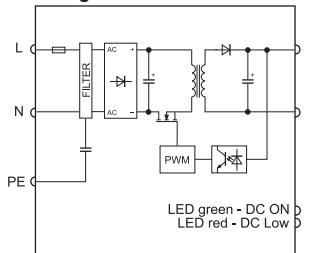

Derating

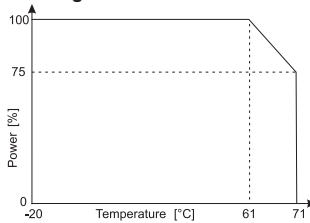

Redundant operation

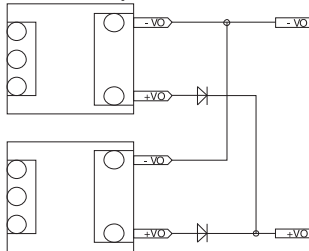

Description	Part-No.	Type	PU	
Screw terminal				
Output voltage/current	DC 5 V / 2 A	728761	DRA10-05A	1
	DC 12 V / 0.84 A	728766	DRA10-12A	1

Input	DRA10-05A	DRA10-12A
Nominal voltage	AC 100–240 V	
Operation voltage range	AC 90–265 V / DC 120–370 V	
Line frequency	47 – 63 Hz	
Rated current	U _i = AC 115 V: 120 mA / U _i = AC 230 V: 70 mA	
Inrush current	U _i = AC 115 V: 10 A / U _i = AC 230 V: 18 A	
Internal fuse	T2 A / AC 250 V	
External fuse	Mini-circuit breaker: B 4 A	
Power Factor Correction P.F.C.	–	

Output	DRA10-05A	DRA10-12A
Rated voltage output	DC 5 V	DC 12 V
Rated current output	2 A	0.84 A
Max. output current	–	
Short-circuit current	–	
Voltage trim range	4.5–5.75 V	10.8–13.8 V
Accuracy	±1 %	
Line regulation	±1 %	
Load regulation	±2 %	
Rise time	1 s	
Temperature coefficient	±0.03 % / °C	
Ripple & Noise	<50 mV	
Hold up time	V _{in} = 115 V: 25 ms / V _{in} = 230 V: 100 ms	
Status indication DC ON LED green	≥4.5 V	≥10.8 V
Status indication DC LOW LED red	<3.75–4.50 V	<9–10.8 V
Parallel/redundant operation	max. 2 devices / via external diodes	
Efficiency	73 %	75 %
Low power loss	4 W (AC 230 V)	3.4 W (AC 230 V)
Rated over load protection	110–135 %	
Over voltage protection	125–145 %	
Short circuit characteristics	Hiccup-mode	

General	
Switching frequency	approx. 100 kHz
Insulation voltage input/output	AC 3.0 kV _{eff}
Insulation voltage input / ground	AC 1.5 kV _{eff}
Insulation voltage output / ground	–
Insulation resistance at DC 500 V	100 MΩ
Operation temperature range	–20 °C – 70 °C (derating)
Derating	–3% / °C starting at 61° C
Storage temperature range	–25 °C – 85 °C
M.T.B.F.	801000 h
Relative humidity	20–95% RH, non-condensing
Dimensions (w × h × d) in mm	22.5 × 90.0 × 115.0

Cooling	Natural air cooling, 25 mm distance on all sides
Housing material	Plastic
Shock resistance	–
Vibration resistance	–
Field installation	rail TS 35 (EN 50022)
Application height	2000 m
Installation position	vertical
Protection class	IP 20
IP rating	II (SELV, PELV)
Overvoltage category	II
Pollution degree	2
Weight (kg/piece)	0.120
Termination	Screw terminal: 0.2–2.5 mm ² , max. 0.56 Nm
Approvals	UL: UL 508 listed; cUL: UL 60950-1, UL 1310 Class 2; TÜV: EN 60950-1, CE: EN 50081-1 / EN 55022 Class B, EN 61000-3-2, EN 601000-3-3, EN 50082-1 / EN 55024
	Class I, Division 2, Groups A, B, C and D

Monitoring	
DC ON Control (Rdy)	LED green/red
Switching voltage	–
Switching current	–
Switching capacity	–
Insulation voltage	–

Power supply · regulated, 10 W

Primary switchmode power supply, Single-phase, Class 2
Input: wide-range input AC 90–265 V, DC 120–370 V
Output: 5 V / 12 V / 15 V / 24 V, adjustable



Dimensions

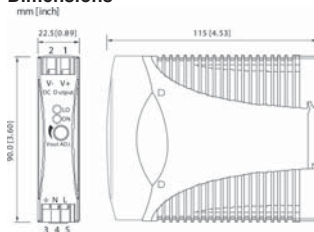

PIN assignment

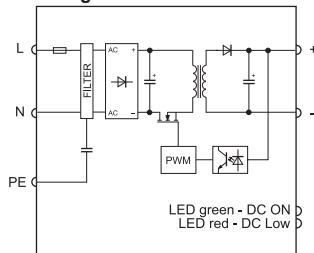

Derating

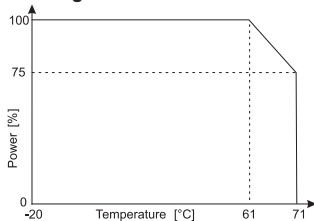

Redundant operation

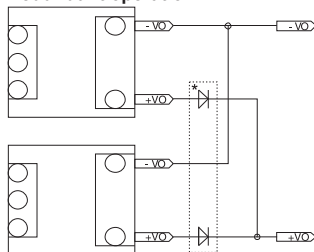

* Redundant Module 722987
 Only use together with 24 V version!

Description	Part-No.	Type	PU	
Spring terminal				
Output voltage/current	DC 5 V / 2 A	722761	DRA10-05	1
	DC 12 V / 0.84 A	722766	DRA10-12	1
	DC 15 V / 0.67 A	722773	DRA10-15	1
	DC 24 V / 0.42 A	722751	DRA10-24	1

Input	DRA10-05	DRA10-12	DRA10-15	DRA10-24
Nominal voltage		AC 100–240 V		
Operation voltage range	AC 90–265 V / DC 120–370 V			
Line frequency	47 – 63 Hz			
Rated current	U _I = AC 115 V: 120 mA / U _I = AC 230 V: 70 mA			
Inrush current	U _I = AC 115 V: 10 A / U _I = AC 230 V: 18 A			
Internal fuse	T2 A / AC 250 V			
External fuse	Mini-circuit breaker: B 4 A			
Power Factor Correction P.F.C.	–			

Output	DRA10-05	DRA10-12	DRA10-15	DRA10-24
Rated voltage output	DC 5 V	DC 12 V	DC 15 V	DC 24 V
Rated current output	2 A	0.84 A	0.67 A	0.42 A
Max. output current	–			
Short-circuit current	–			
Voltage trim range	4.5–5.75 V	10.8–13.8 V	13.5–17.25 V	21.6–28.8 V
Accuracy	±1 %			
Line regulation	±1 %			
Load regulation	±2 %			
Rise time	1 s			
Temperature coefficient	±0.03 % / °C			
Ripple & Noise	<50 mV			
Hold up time	V _{in} = 115 V: 25 ms / V _{in} = 230 V: 100 ms			
Status indication DC ON LED green	≥4.5 V	≥10.8 V	≥13.5 V	≥21.6 V
Status indication DC LOW LED red	<3.75–4.50 V	<9–10.8 V	<11.25–13.5 V	<18–21.6 V
Parallel/redundant operation	max. 2 devices / via external diodes			
Efficiency	73 %	75 %	76 %	77 %
Low power loss	4 W (AC 230 V)	3.4 W (AC 230 V)	3.3 W (AC 230 V)	2.8 W (AC 230 V)
Rated over load protection	110–135 %			
Over voltage protection	125–145 %			
Short circuit characteristics	Hiccup-mode			

General	DRA10-05	DRA10-12	DRA10-15	DRA10-24
Switching frequency	approx. 100 kHz			
Insulation voltage input/output	AC 3.0 kV _{eff}			
Insulation voltage input / ground	AC 1.5 kV _{eff}			
Insulation voltage output / ground	–			
Insulation resistance at DC 500 V	100 MΩ			
Operation temperature range	–20 °C – 70 °C (derating)			
Derating	–3% / °C starting at 61° C			
Storage temperature range	–25 °C – 85 °C			
M.T.B.F.	801000 h	803000 h	805000 h	808000 h

Relative humidity	20–95% RH, non-condensing			
Dimensions (w × h × d) in mm	22.5 × 90.0 × 115.0			
Cooling	Natural air cooling, 25 mm distance on all sides			
Housing material	Plastic			
Shock resistance	–			
Vibration resistance	–			
Field installation	rail TS 35 (EN 50022)			
Application height	2000 m			
Installation position	vertical			
Protection class	IP 20			
IP rating	II (SELV, PELV)			
Overvoltage category	II			
Pollution degree	2			
Weight (kg/piece)	0.120			
Termination	Spring terminal: 0.2–2.0 mm ²			

Approvals	UL: UL 508 listed; cUL: UL 60950-1, UL 1310 Class 2; TÜV: EN 60950-1, CE: EN 50081-1 / EN 55022 Class B, EN 61000-3-2, EN 601000-3-3, EN 50082-1 / EN 55024			
	Class I, Division 2, Groups A, B, C and D			

Monitoring	DRA10-05	DRA10-12	DRA10-15	DRA10-24
DC ON Control (Rdy)	LED green/red			
Switching voltage	–			
Switching current	–			
Switching capacity	–			
Insulation voltage	–			

Power supply · regulated, 15 W

Primary switchmode power supply, Single-phase, Class 2
Input: wide-range input AC 90–265 V, DC 120–370 V
Output: 5 V, adjustable



Dimensions

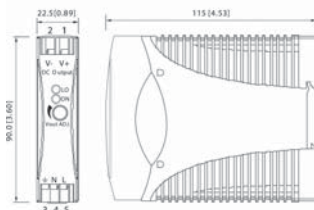

PIN assignment

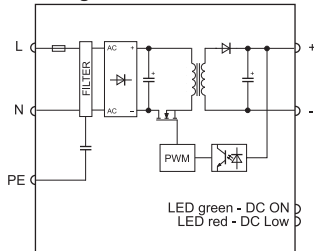

Derating

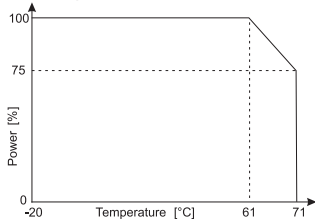

Redundant operation

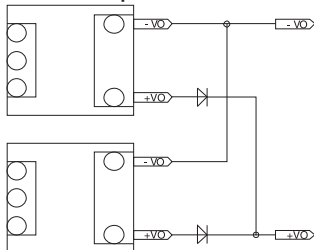

Description	Part-No.	Type	PU	
Screw terminal				
Output voltage/current	DC 5 V / 3 A	728762	DRA18-05A	1
Spring terminal				
Output voltage/current	DC 5 V / 3 A	722762	DRA18-05	1
Input				
	DRA18-05A	DRA18-05		
Nominal voltage		AC 100–240 V		
Operation voltage range		AC 90–265 V / DC 120–370 V		
Line frequency		47 – 63 Hz		
Rated current		U _i = AC 115 V: 170 mA / U _i = AC 230 V: 90 mA		
Inrush current		U _i = AC 115 V: 10 A / U _i = AC 230 V :18 A		
Internal fuse		T2 A / AC 250 V		
External fuse		Mini-circuit breaker: B 4 A		
Power Factor Correction P.F.C.		–		
Output				
Rated voltage output		DC 5 V		
Rated current output		3 A		
Max. output current		–		
Short-circuit current		–		
Voltage trim range		4.5–5.75 V		
Accuracy		±1 %		
Line regulation		±1 %		
Load regulation		±2 %		
Rise time		1 s		
Temperature coefficient		±0.03 % / °C		
Ripple & Noise		<50 mV		
Hold up time		U _i = 115 V: 20 ms / U _i = 230 V: 75 ms		
Status indication DC ON LED green		≥4.5 V		
Status indication DC LOW LED red		<3.75–4.50 V		
Parallel/redundant operation		max. 2 devices / via external diodes		
Efficiency		75 %		
Low power loss		5 W (AC 230 V)		
Rated over load protection		110–135 %		
Over voltage protection		125–145 %		
Short circuit characteristics		Hiccup-mode		
General				
Switching frequency		approx. 100 kHz		
Insulation voltage input/output		AC 3.0 kV _{eff}		
Insulation voltage input / ground		AC 1.5 kV _{eff}		
Insulation voltage output / ground		–		
Insulation resistance at DC 500 V		100 MΩ		
Operation temperature range		-20 °C – 70 °C (derating)		
Derating		-3% / °C starting at 60 °C		
Storage temperature range		-25 °C – 85 °C		
M.T.B.F.		795000 h		
Relative humidity		20–95% RH, non-condensing		
Dimensions (w × h × d) in mm		22.5 × 90.0 × 115.0		
Cooling		Natural air cooling, 25 mm distance on all sides		
Housing material		Plastic		
Shock resistance		–		
Vibration resistance		–		
Field installation		rail TS 35 (EN 50022)		
Application height		2000 m		
Installation position		vertical		
Protection class		IP 20		
IP rating		II (SELV, PELV)		
Overvoltage category		II		
Pollution degree		2		
Weight (kg/piece)		0.150		
Termination		Screw terminal: 0.2–2.5 mm ² , max. 0.56 Nm Spring terminal: 0.2–2.0 mm ²		
Approvals		UL: UL 508 listed; cUL: UL 60950-1, UL 1310 Class 2; TÜV: EN 60950-1, CE: EN 50081-1 / EN 55022 Class B, EN 61000-3-2, EN 601000-3-3, EN 50082-1 / EN 55024 Class I, Division 2, Groups A, B, C and D		
Monitoring				
DC ON Control (Rdy)		LED green/red		
Switching voltage		–		
Switching current		–		
Switching capacity		–		
Insulation voltage		–		

Power supply · regulated, 18 W

Primary switchmode power supply, Single-phase, Class 2
Input: wide-range input AC 90–265 V, DC 120–370 V
Output: 12 V / 15 V / 24 V, adjustable



Dimensions

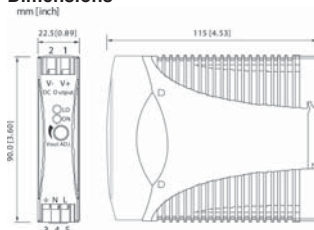

PIN assignment

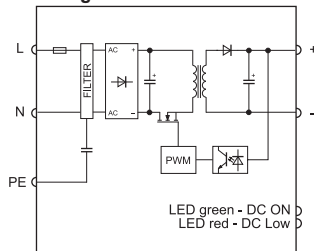

Derating

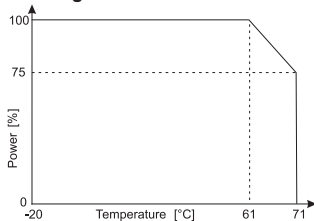

Redundant operation

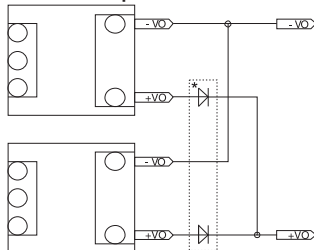

* Redundant Module 722987
 Only use together with 24 V version!

Description	Part-No.	Type	PU	
Spring terminal				
Output voltage/current	DC 12 V / 1.5 A	722767	DRA18-12	1
	DC 15 V / 1.2 A	722774	DRA18-15	1
	DC 24 V / 0.75 A	722752	DRA18-24	1
Input				
	DRA18-12	DRA18-15	DRA18-24	
Nominal voltage	AC 100–240 V			
Operation voltage range	AC 90–265 V / DC 120–370 V			
Line frequency	47 – 63 Hz			
Rated current	U _i = AC 115 V: 200 mA / U _i = AC 230 V: 110 mA			
Inrush current	U _i = AC 115 V: 10 A / U _i = AC 230 V: 18 A			
Internal fuse	T2 A / AC 250 V			
External fuse	Mini-circuit breaker: B 4 A			
Power Factor Correction P.F.C.	–			
Output				
Rated voltage output	DC 12 V	DC 15 V	DC 24 V	
Rated current output	1.5 A	1.2 A	0.75 A	
Max. output current	–			
Short-circuit current	–			
Voltage trim range	10.8–13.8 V	13.5–17.25 V	21.6–28.8 V	
Accuracy	±1 %			
Line regulation	±1 %			
Load regulation	±2 %			
Rise time	1 s			
Temperature coefficient	±0.03 % / °C			
Ripple & Noise	<50 mV			
Hold up time	U _i = 115 V: 20 ms / U _i = 230 V: 75 ms			
Status indication DC ON LED green	≥10.8 V	≥13.5 V	≥21.6 V	
Status indication DC LOW LED red	<9–10.8 V	<11.25–13.5 V	<18–21.6 V	
Parallel/redundant operation	max. 2 devices / via external diodes			
Efficiency	77 %			
Low power loss	4.65 W (AC 230 V)	4.25 W (AC 230 V)	4.45 W (AC 230 V)	
Rated over load protection	110–135 %			
Over voltage protection	125–145 %			
Short circuit characteristics	Hiccup-mode			
General				
Switching frequency	approx. 100 kHz			
Insulation voltage input/output	AC 3.0 kV _{eff}			
Insulation voltage input / ground	AC 1.5 kV _{eff}			
Insulation voltage output / ground	–			
Insulation resistance at DC 500 V	100 MΩ			
Operation temperature range	-20 °C – 70 °C (derating)			
Derating	-3% / °C starting at 60 °C			
Storage temperature range	-25 °C – 85 °C			
M.T.B.F.	797000 h	796000 h	800000 h	
Relative humidity	20–95% RH, non-condensing			
Dimensions (w × h × d) in mm	22.5 × 90.0 × 115.0			
Cooling	Natural air cooling, 25 mm distance on all sides			
Housing material	Plastic			
Shock resistance	–			
Vibration resistance	–			
Field installation	rail TS 35 (EN 50022)			
Application height	2000 m			
Installation position	vertical			
Protection class	IP 20			
IP rating	II (SELV, PELV)			
Overvoltage category	II			
Pollution degree	2			
Weight (kg/piece)	0.150			
Termination	Spring terminal: 0.2–2.0 mm ²			
Approvals	UL: UL 508 listed; cUL: UL 60950-1, UL 1310 Class 2; TÜV: EN 60950-1, CE: EN 50081-1 / EN 55022 Class B, EN 61000-3-2, EN 601000-3-3, EN 50082-1 / EN 55024 Class I, Division 2, Groups A, B, C and D			
Monitoring				
DC ON Control (Rdy)	LED green/red			
Switching voltage	–			
Switching current	–			
Switching capacity	–			
Insulation voltage	–			

Power supply · regulated, 30 W

Primary switchmode power supply, Single-phase, Class 2
Input: wide-range input AC 85–264 V, DC 90–375 V
Output: 5 V / 12 V / 24 V / 48 V, adjustable



Dimensions

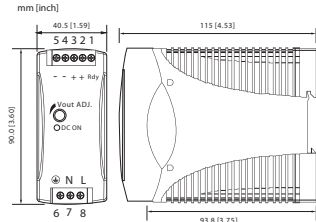

PIN assignment

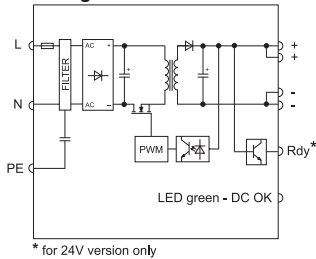

Derating

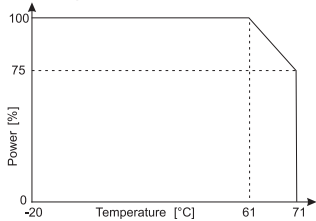

Redundant operation

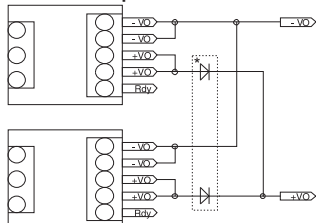

* Redundant Module 722987
 Only use together with 24 V version!

Description	Part-No.	Type	PU	
Screw terminal				
Output voltage/current	DC 5 V / 6 A	722763	DRA30-5A	1
	DC 12 V / 2.5 A	722768	DRA30-12A	1
	DC 24 V / 1.25 A	722753	DRA30-24A	1
	DC 48 V / 0.625 A	722775	DRA30-48A	1

Input	DRA30-5A	DRA30-12A	DRA30-24A	DRA30-48A
Nominal voltage	AC 100–240 V			
Operation voltage range	AC 85–264 V / DC 90–375 V			
Line frequency	47 – 63 Hz			
Rated current	U _i = AC 115 V: 360 mA / U _i = AC 230 V: 190 mA			
Inrush current	U _i = AC 115 V: 20 A / U _i = AC 230 V: 40 A			
Internal fuse	T2 A / AC 250 V			
External fuse	Mini-circuit breaker: B 4 A			
Power Factor Correction P.F.C.	–			

Output	DRA30-5A	DRA30-12A	DRA30-24A	DRA30-48A
Rated voltage output	DC 5 V	DC 12 V	DC 24 V	DC 48 V
Rated current output	6 A	2.5 A	1.25 A	0.625
Max. output current	–			
Short-circuit current	–			
Voltage trim range	5–5.5 V	12/14 V	24/28 V	48/55 V
Accuracy	±1 %			
Line regulation	±0.5 %			
Load regulation	±0.5 %			
Rise time	1 s			
Temperature coefficient	±0.03 % / °C			
Ripple & Noise	<50 mV			
Hold up time	V _{in} = 115 V: 20 ms / V _{in} = 230 V: 30 ms			
Status indication DC ON LED green	≥4 V	≥9.6 V	≥19.2 V	≥37 V
Status indication DC LOW LED red	–			
Parallel/redundant operation	max. 2 devices / via external diodes			
Efficiency	79 %	84 %	86 %	
Low power loss	8.5 W (AC 230 V)	5.6 W (AC 230 V)	5.5 W (AC 230 V)	4.9 W (AC 230 V)
Rated over load protection	120 – 136 %	110 – 140 %		
Over voltage protection	125–137 %			
Short circuit characteristics	Hiccup-mode			
General				
Switching frequency	approx. 80 kHz			
Insulation voltage input/output	AC 3.0 kV _{eff}			
Insulation voltage input / ground	AC 1.5 kV _{eff}			
Insulation voltage output / ground	–			
Insulation resistance at DC 500 V	100 MΩ			
Operation temperature range	–25 °C – 70 °C (derating)			
Derating	–2.5% / °C starting at 60 °C			
Storage temperature range	–25 °C – 85 °C			
M.T.B.F.	551000 h	582000 h	588000 h	609000 h
Relative humidity	20–90% RH, non-condensing			
Dimensions (w × h × d) in mm	40.5 × 90.0 × 115.0			
Cooling	Natural air cooling, 25 mm distance on all sides			
Housing material	Plastic			
Shock resistance	–			
Vibration resistance	–			
Field installation	rail TS 35 (EN 50022)			
Application height	2000 m			
Installation position	vertical			
Protection class	IP 20			
IP rating	II (SELV, PELV)			
Overvoltage category	II			
Pollution degree	2			
Weight (kg/piece)	0.290			
Termination	Screw terminal: 0.2–2.5 mm ² , max. 0.56 Nm			

Approvals
 UL: UL 508 listed; cUL: UL 60950-1, UL 1310 Class 2; TÜV: EN 60950-1, CE: EN 61000-6-3 / EN 55022 Class B, EN 61000-3-2, EN 61000-3-3, EN 55024, EN 61000-6-2, EN 61000-4-2, EN 61000-4-3, EN 61000-4-4, EN 61000-4-5, EN 61000-4-6, EN 61000-4-8, EN 61000-4-11

Monitoring			
DC ON Control (Rdy)	–	Open Collector	–
Switching voltage	–	DC 24 V	–
Switching current	–	≤ 35 mA	–
Switching capacity	–	–	–
Insulation voltage	–	none	–

Power supply · regulated, 30 W

Primary switchmode power supply, Single-phase, Class 2
Input: wide-range input AC 85–264 V, DC 90–375 V
Output: 5 V / 12 V / 24 V / 48 V, adjustable



Dimensions

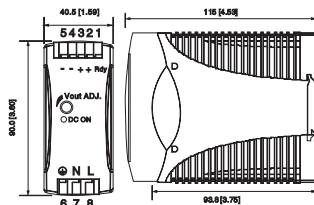

PIN assignment

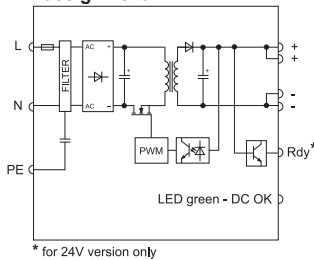

* for 24V version only

Derating

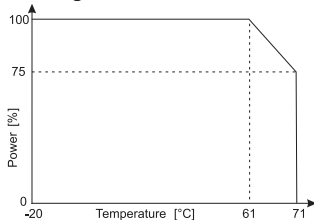

Redundant operation

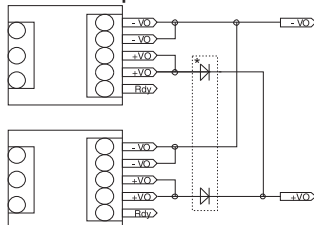

* Redundant Module 722987
 Only use together with 24 V version!

Description	Part-No.	Type	PU	
Spring terminal				
Output voltage/current	DC 5 V / 6 A	728763	DRA30-05	1
	DC 12 V / 2.5 A	728768	DRA30-12	1
	DC 24 V / 1.25 A	728753	DRA30-24	1
	DC 48 V / 0.625 A	728775	DRA30-48	1

Input	DRA30-05	DRA30-12	DRA30-24	DRA30-48
Nominal voltage	AC 100–240 V			
Operation voltage range	AC 85–264 V / DC 90–375 V			
Line frequency	47 – 63 Hz			
Rated current	U _i = AC 115 V: 360 mA / U _i = AC 230 V: 190 mA			
Inrush current	U _i = AC 115 V: 20 A / U _i = AC 230 V: 40 A			
Internal fuse	T2 A / AC 250 V			
External fuse	Mini-circuit breaker: B 4 A			
Power Factor Correction P.F.C.	–			
Output				
Rated voltage output	DC 5 V	DC 12 V	DC 24 V	DC 48 V
Rated current output	6 A	2.5 A	1.25 A	0.625
Max. output current	–			
Short-circuit current	–			
Voltage trim range	5–5.5 V	12/14 V	24/28 V	48/55 V
Accuracy	±1 %			
Line regulation	±0.5 %			
Load regulation	±0.5 %			
Rise time	1 s			
Temperature coefficient	±0.03 % / °C			
Ripple & Noise	<50 mV			
Hold up time	V _{in} = 115 V: 20 ms / V _{in} = 230 V: 30 ms			
Status indication DC ON LED green	≥4 V	≥9.6 V	≥19.2 V	≥37 V
Status indication DC LOW LED red	–			
Parallel/redundant operation	max. 2 devices / via external diodes			
Efficiency	79 %	84 %	86 %	
Low power loss	8.5 W (AC 230 V)	5.6 W (AC 230 V)	5.5 W (AC 230 V)	4.9 W (AC 230 V)
Rated over load protection	110–140 %			
Over voltage protection	120–136 %	125–137 %		–
Short circuit characteristics	Hiccup-mode			
General				
Switching frequency	approx. 80 kHz			
Insulation voltage input/output	AC 3.0 kV _{eff}			
Insulation voltage input / ground	AC 1.5 kV _{eff}			
Insulation voltage output / ground	–			
Insulation resistance at DC 500 V	100 MΩ			
Operation temperature range	–25 °C – 70 °C (derating)			
Derating	–2.5 % / °C starting at 60 °C			
Storage temperature range	–25 °C – 85 °C			
M.T.B.F.	551000 h	582000 h	588000 h	609000 h
Relative humidity	20–90% RH, non-condensing			
Dimensions (w × h × d) in mm	40.5 × 90.0 × 116.0			
Cooling	Natural air cooling, 25 mm distance on all sides			
Housing material	Plastic			
Shock resistance	–			
Vibration resistance	–			
Field installation	rail TS 35 (EN 50022)			
Application height	2000 m			
Installation position	vertical			
Protection class	IP 20			
IP rating	II (SELV, PELV)			
Overvoltage category	II			
Pollution degree	2			
Weight (kg/piece)	0.290			
Termination	Spring terminal: 0.2–2.0 mm ²			
Approvals	UL: UL 508 listed; cUL: UL 60950-1; TÜV: EN 60950-1, CE: EN 61000-6-3 / EN 55022 Class B; EN 61000-3-2, EN 61000-3-3; EN 55024; EN 61000-6-2; EN 61000-4-2; EN 61000-4-3, EN 61000-4-4; EN 61000-4-5; EN 61000-4-6; EN 61000-4-8; EN 61000-4-11			
Monitoring				
DC ON Control (Rdy)	–	Open Collector		–
Switching voltage	–	DC 24 V		–
Switching current	–	≤ 35 mA		–
Switching capacity	–	–		–
Insulation voltage	–	none		–

Power supply - regulated, 50 W

Primary switchmode power supply, Single-phase, Class 2
Input: wide-range input AC 85–264 V, DC 90–375 V
Output: 5 V, adjustable

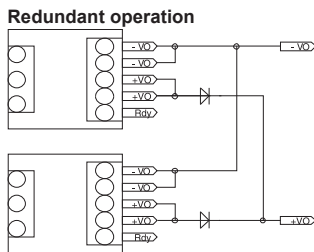
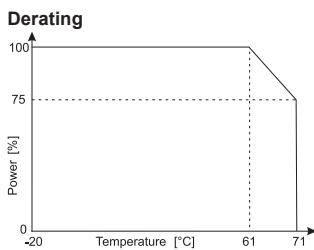
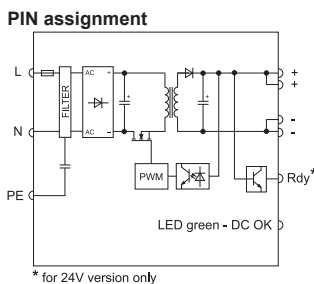
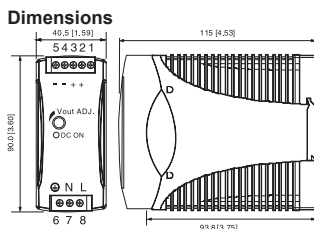

Description	Part-No.	Type	PU	
Screw terminal				
Output voltage/current	DC 5 V / 10 A	722764	DRA60-05A	1
Spring terminal				
Output voltage/current	DC 5 V / 10 A	728764	DRA60-05	1
Input				
	DRA60-05A	DRA60-05		
Nominal voltage	AC 100–240 V			
Operation voltage range	AC 85–264 V / DC 90–375 V			
Line frequency	47 – 63 Hz			
Rated current	U _i = AC 115 V, AC: 550 mA / U _i = 230 V; U _i = AC 115 V, AC: 550 mA / U _i = 230 V, AC: 280 mA			
Inrush current	U _i = AC 115 V: 20 A / U _i = AC 230 V: 40 A			
Internal fuse	T2 A / AC 250 V			
External fuse	Mini-circuit breaker: B 4 A, C 2 A			
Power Factor Correction P.F.C.	–			
Output				
Rated voltage output	DC 5 V			
Rated current output	10 A			
Max. output current	–			
Short-circuit current	–			
Voltage trim range	5.0/5.5 V			
Accuracy	±1 %			
Line regulation	±0.5 %			
Load regulation	±0.5 %			
Rise time	1 s			
Temperature coefficient	±0.03 % / °C			
Ripple & Noise	50 mV			
Hold up time	V _{in} = 115 V: 20 ms / V _{in} = 230 V: 30 ms			
Status indication DC ON LED green	≥4 V			
Status indication DC LOW LED red	–			
Parallel/redundant operation	max. 2 devices / via external diodes			
Efficiency	79 %			
Low power loss	12.5 W (AC 230 V)			
Rated over load protection	110–150 %			
Over voltage protection	120–136 %			
Short circuit characteristics	Hiccup-mode			
General				
Switching frequency	approx. 80 kHz			
Insulation voltage input/output	AC 3.0 kV _{eff}			
Insulation voltage input / ground	AC 1.5 kV _{eff}			
Insulation voltage output / ground	–			
Insulation resistance at DC 500 V	100 MΩ			
Operation temperature range	–25 °C – 70 °C (derating)			
Derating	–2.5% / °C starting at 60 °C			
Storage temperature range	–25 °C – 85 °C			
M.T.B.F.	498000 h			
Relative humidity	20–90% RH, non-condensing			
Dimensions (w × h × d) in mm	40.5 × 90.0 × 115.0			
Cooling	Natural air cooling, 25 mm distance on all sides			
Housing material	Plastic			
Shock resistance	–			
Vibration resistance	–			
Field installation	rail TS 35 (EN 50022)			
Application height	2000 m			
Installation postition	vertical			
Protection class	IP 20			
IP rating	II (SELV, PELV)			
Overvoltage category	II			
Pollution degree	2			
Weight (kg/piece)	0.340			
Termination	Screw terminal: 0.2–2.5 mm ² , max. 0.56 Nm		Spring terminal 0.2–2.0 mm ²	
Approvals	UL: UL 508 listed; cUL: UL 60950-1; TÜV: EN 60950-1, CE: EN 61000-6-3 / EN 55022 Class B; EN 61000-3-2, EN 601000-3-4; EN 55024; EN 61000-6-2; EN 61000-4-2; EN 61000-4-3, EN 61000-4-4; EN 61000-4-5; EN 61000-4-6; EN 61000-4-8; EN 61000-4-11			
Monitoring				
DC ON Control (Rdy)	–			
Switching voltage	–			
Switching current	–			
Switching capacity	–			
Insulation voltage	–			

Power supply · regulated, 60 W

Primary switchmode power supply, Single-phase, Class 2
Input: wide-range input AC 85–264 V, DC 90–375 V
Output: 12 V / 24 V / 48 V, adjustable



Dimensions

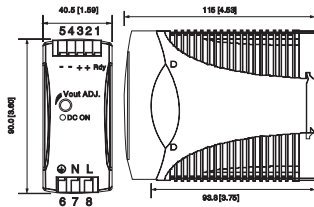

PIN assignment

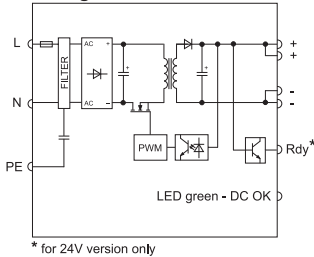

Derating

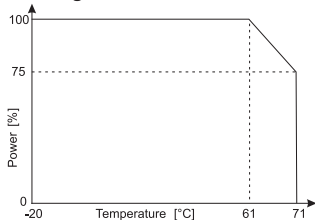

Redundant operation

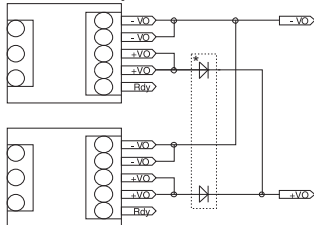

Description	Part-No.	Type	PU	
Spring terminal				
Output voltage/current	DC 12 V / 5 A	728769	DRA60-12	1
	DC 24 V / 2.5 A	728754	DRA60-24	1
	DC 48 V / 1.25 A	728776	DRA60-48	1
Input				
	DRA60-12	DRA60-24	DRA60-48	
Nominal voltage	AC 100–240 V			
Operation voltage range	AC 85–264 V / DC 90–375 V			
Line frequency	47 – 63 Hz			
Rated current	U _i = AC 115 V: 690 mA / U _i = AC 230 V: 360 mA			
Inrush current	U _i = AC 115 V: 20 A / U _i = AC 230 V: 40 A			
Internal fuse	T2 A / AC 250 V			
External fuse	Mini-circuit breaker: B 6 A			
Power Factor Correction P.F.C.	–			
Output				
Rated voltage output	DC 12 V	DC 24 V	DC 48 V	
Rated current output	5 A	2.5 A	1.25 A	
Max. output current	–			
Short-circuit current	–			
Voltage trim range	12/14 V	24/28 V	48/55 V	
Accuracy	±1 %			
Line regulation	±0.5 %			
Load regulation	±0.5 %			
Rise time	1 s			
Temperature coefficient	±0.03 % / °C			
Ripple & Noise	50 mV			
Hold up time	V _{in} = 115 V: 20 ms / V _{in} = 230 V: 30 ms			
Status indication DC ON LED green	≥9.6 V	≥19.2 V	≥37 V	
Status indication DC LOW LED red	–			
Parallel/redundant operation	max. 2 devices / via external diodes			
Efficiency	86 %	89 %		
Low power loss	9.0 W (AC 230 V)	8.8 W (AC 230 V)	7.8 W (AC 230 V)	
Rated over load protection	110–150 %			
Over voltage protection	125–138 %			
Short circuit characteristics	Hiccup-mode			
General				
Switching frequency	approx. 80 kHz			
Insulation voltage input/output	AC 3.0 kV _{eff}			
Insulation voltage input / ground	AC 1.5 kV _{eff}			
Insulation voltage output / ground	–			
Insulation resistance at DC 500 V	100 MΩ			
Operation temperature range	-25 °C – 70 °C (derating)			
Derating	-2.5% / °C starting at 60 °C			
Storage temperature range	-25 °C – 85 °C			
M.T.B.F.	504000 h	520000 h	531000 h	
Relative humidity	20–90% RH, non-condensing			
Dimensions (w × h × d) in mm	40.5 × 90.0 × 115.0			
Cooling	Natural air cooling, 25 mm distance on all sides			
Housing material	Plastic			
Shock resistance	–			
Vibration resistance	–			
Field installation	rail TS 35 (EN 50022)			
Application height	2000 m			
Installation position	vertical			
Protection class	IP 20			
IP rating	II (SELV, PELV)			
Overvoltage category	II			
Pollution degree	2			
Weight (kg/piece)	0.340			
Termination	Spring terminal 0.2–2.0 mm ²			
Approvals	UL: UL 508 listed; cUL: UL 60950-1, UL 1310 Class 2 (not 12 V) recognised; TÜV: EN 60950-1, EN 61558-1, EN 61558-2-17 CE: EN 61000-6-3 / EN 55022 Class B; EN 61000-3-2 EN 61000-3-3; EN 55024; EN 61000-6-2; EN 61000-4-2; EN 61000-4-3 EN 61000-4-4; EN 61000-4-5; EN 61000-4-6; EN 61000-4-8; EN 61000-4-11			
Monitoring				
DC ON Control (Rdy)	–	Open Collector	–	
Switching voltage	–	DC 24 V	–	
Switching current	–	≤ 35 mA	–	
Switching capacity	–			
Insulation voltage	–	none	–	

Power supply · regulated, 60 W

Primary switchmode power supply, Single-phase, Class 2
Input: wide-range input AC 85–264 V, DC 90–375 V
Output: 12 V / 24 V / 48 V, adjustable



Dimensions

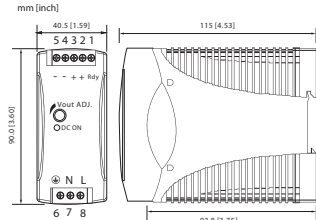

PIN assignment

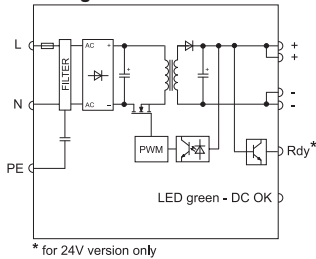

Derating

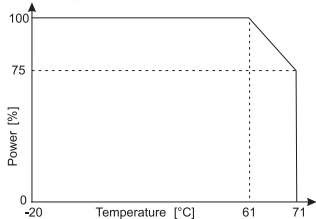

Redundant operation

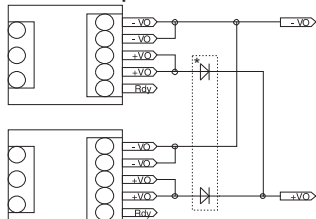

* Redundant Module 722987
 Only use together with 24 V version!

Description	Part-No.	Type	PU	
Screw terminal				
Output voltage/current	DC 12 V / 5 A	722769	DRA60-12A	1
	DC 24 V / 2.5 A	722754	DRA60-24A	1
	DC 48 V / 1.25 A	722776	DRA60-48A	1
Input				
	DRA60-12A	DRA60-24A	DRA60-48A	
Nominal voltage	AC 100–240 V			
Operation voltage range	AC 85–264 V / DC 90–375 V			
Line frequency	47 – 63 Hz			
Rated current	U _i = AC 115 V: 690 mA / U _i = AC 230 V: 360 mA			
Inrush current	U _i = AC 115 V: 20 A / U _i = AC 230 V: 40 A			
Internal fuse	T2 A / AC 250 V			
External fuse	Mini-circuit breaker: B 6 A			
Power Factor Correction P.F.C.	–			
Output				
Rated voltage output	DC 12 V	DC 24 V	DC 48 V	
Rated current output	5 A	2.5 A	1.25 A	
Max. output current	–			
Short-circuit current	–			
Voltage trim range	12/14 V	24/28 V	48/55 V	
Accuracy	±1 %			
Line regulation	±0.5 %			
Load regulation	±0.5 %			
Rise time	1 s			
Temperature coefficient	±0.03 % / °C			
Ripple & Noise	50 mV			
Hold up time	V _{in} = 115 V: 20 ms / V _{in} = 230 V: 30 ms			
Status indication DC ON LED green	≥9.6 V	≥19.2 V	≥37 V	
Status indication DC LOW LED red	–			
Parallel/redundant operation	max. 2 devices / via external diodes			
Efficiency	86 %	89 %		
Low power loss	9.0 W (AC 230 V)	8.8 W (AC 230 V)	7.8 W (AC 230 V)	
Rated over load protection	110–150 %			
Over voltage protection	125–138 %			
Short circuit characteristics	Hiccup-mode			
General				
Switching frequency	approx. 80 kHz			
Insulation voltage input/output	AC 3.0 kV _{eff}			
Insulation voltage input / ground	AC 1.5 kV _{eff}			
Insulation voltage output / ground	–			
Insulation resistance at DC 500 V	100 MΩ			
Operation temperature range	–25 °C – 70 °C (derating)			
Derating	–2.5% / °C starting at 60 °C			
Storage temperature range	–25 °C – 85 °C			
M.T.B.F.	504000 h	520000 h	531000 h	
Relative humidity	20–90% RH, non-condensing			
Dimensions (w × h × d) in mm	40.5 × 90.0 × 115.0			
Cooling	Natural air cooling, 25 mm distance on all sides			
Housing material	Plastic			
Shock resistance	–			
Vibration resistance	–			
Field installation	rail TS 35 (EN 50022)			
Application height	2000 m			
Installation position	vertical			
Protection class	IP 20			
IP rating	II (SELV, PELV)			
Overvoltage category	II			
Pollution degree	2			
Weight (kg/piece)	0.340			
Termination	Screw terminal: 0.2–2.5 mm ² , max. 0.56 Nm			
Approvals	UL: UL 508 listed; cUL: UL 60950-1, UL 1310 Class 2 (not 12 V) recognised; TÜV: EN 60950-1, EN 61558-1, EN 61558-2-17 CE: EN 61000-6-3 / EN 55022 Class B; EN 61000-3-2 EN 61000-3-3; EN 55024; EN 61000-6-2; EN 61000-4-2; EN 61000-4-3 EN 61000-4-4; EN 61000-4-5; EN 61000-4-6; EN 61000-4-8; EN 61000-4-11			
Monitoring				
DC ON Control (Rdy)	–	Open Collector	–	
Switching voltage	–	DC 24 V	–	
Switching current	–	≤ 35 mA	–	
Switching capacity	–	–	–	
Insulation voltage	–	none	–	

Power supply · regulated, 93 W, Class 2 compliant

Primary switched power supplies, PFC, one-phase, screw terminal
Input: wide-range input AC 90–132 V, AC 186–264 V, DC 210–370 V
Output: 24 V, adjustable

NEC Class 2



Dimensions

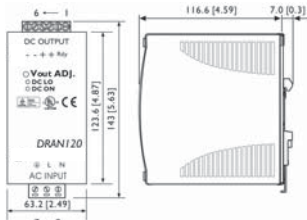

PIN assignment

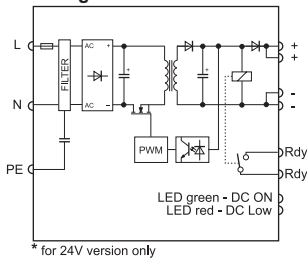

Derating

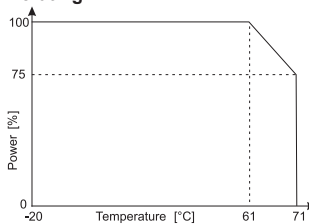

Parallel mode

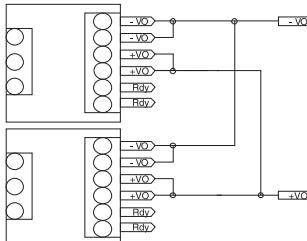

Redundant operation

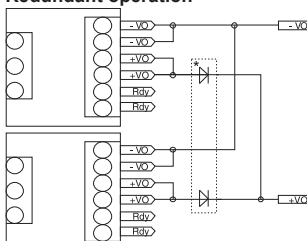

* Redundant Module 722987

Description	Part-No.	Type	PU
Screw terminal, pluggable			
Output voltage/current	DC 24 V/ 3.8 A	722757	DRAN 120-24AL
			1
Input	DRAN 120-24AL		
Nominal voltage	AC 115 / 230 V (auto select)		
Operation voltage range	AC 90–132 V; AC 186–264 V / DC 210–370 V		
Line frequency	47 – 63 Hz		
Rated current	U _i = AC 115 V: 1.1 A / U _i = AC 230 V: 0.55 A		
Inrush current	U _i = AC 115 V: 24 A / U _i = AC 230 V: 48 A		
Internal fuse	T3, 15 A / AC 250 V		
External fuse	Mini-circuit breaker: B 6 A		
Power Factor Correction P.F.C.	0.7		
Output			
Rated voltage output	DC 24 V		
Rated current output	3.8 A		
Max. output current	–		
Short-circuit current	–		
Voltage trim range	22.5–28.5 V		
Accuracy	±1 %		
Line regulation	±0.5 %		
Load regulation	Single ±1 %, Parallel ±5 %		
Rise time	1 s		
Temperature coefficient	±0.03 % / °C		
Ripple & Noise	50 mV		
Hold up time	V _{in} = 115 V: 25 ms / V _{in} = 230 V: 30 ms		
Status indication DC ON LED green	≥17.6–19.4 V		
Status indication DC LOW LED red	≤17.6–19.4 V		
Parallel/redundant operation	max 2 devices with 90 % load current each / via external diodes		
Efficiency	86 %		
Low power loss	16 W (AC 230 V)		
Rated over load protection	105–125 %		
Over voltage protection	125–145 %		
Short circuit characteristics	Current limit		
General			
Switching frequency	approx. 80 kHz		
Insulation voltage input/output	AC 3.0 kV _{eff}		
Insulation voltage input / ground	AC 1.5 kV _{eff}		
Insulation voltage output / ground	–		
Insulation resistance at DC 500 V	100 MΩ		
Operation temperature range	-25 °C – 70 °C (derating)		
Derating	-2.5% / °C starting at 60 °C		
Storage temperature range	-25 °C – 85 °C		
M.T.B.F.	486000 h		
Relative humidity	20–90% RH, non-condensing		
Dimensions (w × h × d) in mm	63.5 × 142.0 × 116.0		
Cooling	Natural air cooling, 25 mm distance on all sides		
Housing material	metal		
Field installation	rail TS 35 (EN 50022)		
Application height	2000 m		
Installation position	vertical		
Protection class	IP 20		
IP rating	I (SELV, PELV)		
Overvoltage category	II		
Pollution degree	2		
Weight (kg/piece)	0.920		
Termination	Screw terminal: 0.2–2.5 mm ² , max. 0.56 Nm		
Approvals	UL: UL 508 listed, cUL: UL 60950-1, TÜV: EN 60950, EN 55022 Class B, EN 55024 Class 2, EN 61000-3-2, EN 61000-3-3, EN 61000-6-2, EN 61000-6-3 Class I, Division 2, Groups A, B, C and D		
Monitoring			
DC ON Control (Rdy)	Normally open		
Switching voltage	DC 60 V		
Switching current	max. 300 mA		
Switching capacity	–		
Insulation voltage	DC 500 V		

Power supply · regulated, 120 W

Primary switchmode power supply, PFC, Single-phase

Input: wide-range input AC 90–132 V, AC 186–264 V, DC 210–370 V

Output: 12 V / 24 V / 48 V, adjustable



Dimensions

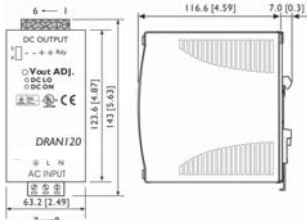

PIN assignment

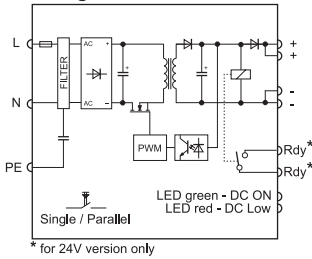

Derating

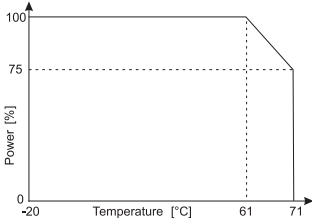

Parallel/redundant mode

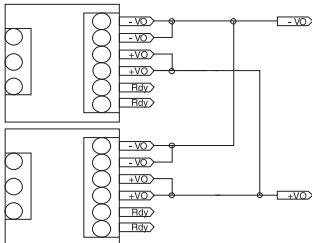

Description	Part-No.	Type	PU	
Screw terminal, pluggable				
Output voltage/current	DC 12 V/ 10 A	722770	DRAN120-12B	1
	DC 24 V/ 5 A	722758	DRAN120-24B	1
	DC 48 V/ 2.5 A	722777	DRAN120-48B	1
Screw terminal				
Output voltage/current	DC 24 V/ 5 A	728758	DRAN120-24A	1
Input				
	DRAN120-12B	DRAN120-24B	DRAN120-48B	DRAN120-24A
Nominal voltage	AC 115 / 230 V (auto select)			
Operation voltage range	AC 90–132 V; AC 186–264 V / DC 210–370 V			
Line frequency	47 – 63 Hz			
Rated current	U _i = AC 115 V: 1.25 A / U _i = AC 230 V: 0.63 A			
Inrush current	U _i = AC 115 V: 24 A / U _i = AC 230 V: 48 A			
Internal fuse	T3, 15 A / AC 250 V			
External fuse	Mini-circuit breaker: B 6 A			
Power Factor Correction P.F.C.	0.7			
Output				
Rated voltage output	DC 12 V	DC 24 V	DC 48 V	DC 24 V
Rated current output	10 A	5 A	2.5 A	5 A
Max. output current	–			
Short-circuit current	–			
Voltage trim range	11.4–14.5 V	22.5–28.5 V	45/55 V	22.5–28.5 V
Accuracy	±1 %			
Line regulation	±0.5 %			
Load regulation	Single ±1 %, Parallel ±5 %			
Rise time	1 s			
Temperature coefficient	±0.03 % / °C			
Ripple & Noise	50 mV			
Hold up time	V _{in} = 115 V: 25 ms / V _{in} = 230 V: 30 ms			
Status indication DC ON LED green	≥10–11.2 V	≥17.6–19.4 V	≥37–43 V	≥17.6–19.4 V
Status indication DC LOW LED red	≤10–11.2 V	≤17.6–19.4 V	≤37–43 V	≤17.6–19.4 V
Parallel/redundant operation	max. 3 units at 90% load current, manual switch			
Efficiency	84 %	86 %	87 %	86 %
Low power loss	24 W (AC 230 V)	20 W (AC 230 V)	19 W (AC 230 V)	20 W (AC 230 V)
Rated over load protection	105–125 %			
Over voltage protection	125–145 %			
Short circuit characteristics	Current limit			
General				
Switching frequency	approx. 80 kHz			
Insulation voltage input/output	AC 3.0 kV _{eff}			
Insulation voltage input / ground	AC 1.5 kV _{eff}			
Insulation voltage output / ground	–			
Insulation resistance at DC 500 V	100 MΩ			
Operation temperature range	-25 °C – 70 °C (derating)			
Derating	-2.5% / °C starting at 60 °C			
Storage temperature range	-25 °C – 85 °C			
M.T.B.F.	440000 h	450000 h	482000 h	450000 h
Relative humidity	20–90% RH, non-condensing			
Dimensions (w × h × d) in mm	63.5 × 142.0 × 116.0			
Cooling	Natural air cooling, 25 mm distance on all sides			
Housing material	metal			
Shock resistance	–			
Vibration resistance	–			
Field installation	rail TS 35 (EN 50022)			
Application height	2000 m			
Installation position	vertical			
Protection class	IP 20			
IP rating	I (SELV, PELV)			
Overvoltage category	II			
Pollution degree	2			
Weight (kg/piece)	0.920			
Termination	Screw terminal: 0.2–2.5 mm ² - pluggable,max. 0.56 Nm			Screw terminal: 0.2–4.0 mm ² , max. 0.62 Nm
Approvals	UL: UL 508 listed; cUL: UL 60950-1; TÜV: EN 60950, CE: EN 61000-6-3, EN 55022 Class B, EN 61000-3-2, EN 61000-3-3, EN 61000-6-2, EN 55024 Class I, Division 2, Groups A, B, C and D			
Monitoring				
DC ON Control (Rdy)	–	Normally open	–	Normally open
Switching voltage	–	DC 60 V	–	DC 60 V
Switching current	–	max. 300 mA	–	max. 300 mA
Switching capacity	–	–	–	–
Insulation voltage	–	DC 500 V	–	DC 500 V

Power supply · regulated, 120 W, 3-phase

Primary switchmode power supply, PFC, 3-phase
Input: wide-range input AC 340–576 V, DC 480–820 V
Output: 24 V, adjustable



Dimensions

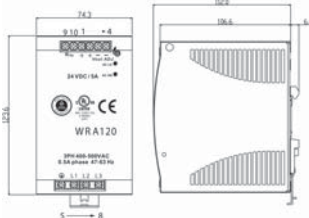

PIN assignment

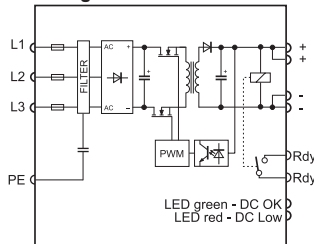

Derating

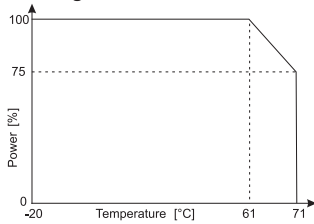

Redundant operation

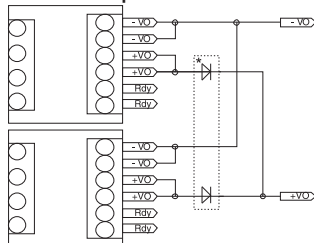

* Redundant Module 722987

Description	Part-No.	Type	PU
Screw terminal			
Output voltage/current	DC 24 V/ 5 A	722803	WRA120-24
			1
Input			
WRA120-24			
Nominal voltage	3× AC 380–480 V		
Operation voltage range	3× AC 340–575 V, 3× DC 480–820 V		
Line frequency	47 – 63 Hz		
Rated current	U _i = AC 380 V: 0.5 A / U _i = AC 500 V: 0.35 A		
Inrush current	10 A		
Internal fuse	3×T2, 0 A / AC 600 V		
External fuse	Automatic: 3 × B 6 A		
Power Factor Correction P.F.C.	0.6		
Output			
Rated voltage output	DC 24 V		
Rated current output	5 A		
Max. output current	–		
Short-circuit current	–		
Voltage trim range	22.5/28.5 V		
Accuracy	1 %		
Line regulation	±1 %		
Load regulation	±1 %		
Rise time	1 s		
Temperature coefficient	±0.03 % / °C		
Ripple & Noise	100 mV		
Hold up time	min. 20 ms		
Status indication DC ON LED green	≥17.6–19.4 V		
Status indication DC LOW LED red	≤17.6–19.4 V		
Parallel/redundant operation	max. 2 devices / via external diodes		
Efficiency	89 %		
Low power loss	16 W (AC 380 V)		
Rated over load protection	115 - 135 %, temperature: disconnection at 100–110°C and automatic activation when cool off		
Over voltage protection	125–137 %		
Short circuit characteristics	Hiccup-mode		
General			
Switching frequency	approx. 70 kHz		
Insulation voltage input/output	AC 3.0 kV _{eff}		
Insulation voltage input / ground	AC 1.5 kV _{eff}		
Insulation voltage output / ground	–		
Insulation resistance at DC 500 V	100 MΩ		
Operation temperature range	-25 °C – 71 °C (derating)		
Derating	Capacity: -2.5% / °C starting at +61 °C		
Storage temperature range	-25 °C – 85 °C		
M.T.B.F.	559000 h		
Relative humidity	20–90% RH, non-condensing		
Dimensions (w × h × d) in mm	74.3 × 123.6 × 118.8		
Cooling	Natural air cooling, 25 mm distance on all sides		
Housing material	Metal		
Shock resistance	–		
Vibration resistance	–		
Field installation	rail TS 35 (EN 50022)		
Application height	3000 m		
Installation position	vertical		
Protection class	IP 20		
IP rating	I (SELV, PELV)		
Overvoltage category	II		
Pollution degree	2		
Weight (kg/piece)	0.800		
Termination	Screw terminal: 0.2–4.0 mm ² , max. 0.62 Nm		
Approvals	UL: UL 508 listed, cUL: UL 60950-1 accepted, TÜV: EN 60950-1; CE: EN 61000-6-3 / EN 55022 Class B, EN 61000-3-2, EN 61000-3-3, EN 61000-6-2, EN 55024 Class I, Division 2, Groups A, B, C and D		
Monitoring			
DC ON Control (Rdy)	Normally open		
Switching voltage	DC 60 V		
Switching current	max. 300 mA		
Switching capacity	–		
Insulation voltage	DC 500 V		

Power supply · regulated, 240 W

Primary switchmode power supply, PFC, Single-phase

Input: wide-range input AC 93–132 V, AC 186–264 V, DC 210–370 V

Output: 24 V / 48 V, adjustable



Dimensions

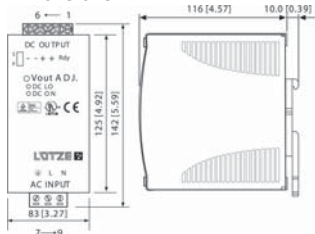

PIN assignment

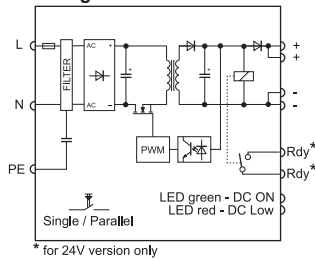

Derating

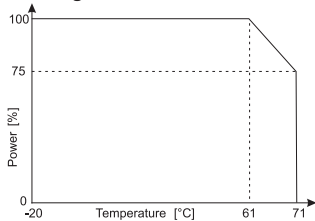

Parallel/redundant mode

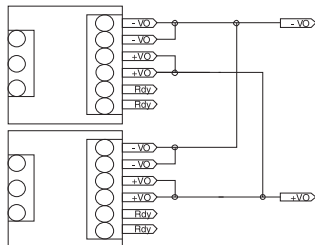

Description	Part-No.	Type	PU	
Screw terminal, pluggable				
Output voltage/current	DC 24 V / 10 A	722759	DRA240-24B	1
	DC 48 V / 5 A	722778	DRA240-48B	1
Screw terminal				
Output voltage/current	DC 24 V / 10 A	722781	DRA240-24A	1

Input	DRA240-24B	DRA240-48B	DRA240-24A
Nominal voltage	AC 115 / 230 V (auto select)		
Operation voltage range	AC 88 V - 264 V / DC 120 V - 375 V		
Line frequency	47 – 63 Hz		
Rated current	U _i = AC 115 V: 2.4 A / U _i = AC 230 V: 1.2 A		
Inrush current	U _i = AC 115 V: 30 A / U _i = AC 230 V: 60 A		
Internal fuse	T6, 3 A / AC 250 V		
External fuse	Mini-circuit breaker: B 10 A, C 6 A		
Power Factor Correction P.F.C.	0.7		

Output	DRA240-24B	DRA240-48B	DRA240-24A
Rated voltage output	DC 24 V	DC 48 V	DC 24 V
Rated current output	10 A	5 A	10 A
Max. output current	–		
Short-circuit current	–		
Voltage trim range	22.5–28.5	47/56 V	22.5–28.5 V
Accuracy	±1 %		
Line regulation	±0.5 %		
Load regulation	Single ±1 %, Parallel ±5 %		
Rise time	1 s		
Temperature coefficient	±0.03 % / °C		
Ripple & Noise	100 mV		
Hold up time	V _{in} = 115 V: 25 ms / V _{in} = 230 V: 30 ms		
Status indication DC ON LED green	≥17.6–19.4 V	≥37–43 V	≥17.6–19.4 V
Status indication DC LOW LED red	≤17.6–19.4 V	≤37–43 V	≤17.6–19.4 V
Parallel/redundant operation	max 3 devices with 90 % load current each, switching with switch S/P		
Efficiency	89 %	90 %	89 %
Low power loss	35 W (AC 230 V)	32 W (AC 230 V)	35 W (AC 230 V)
Rated over load protection	105–145 %		
Over voltage protection	120–145 %		
Short circuit characteristics	Current limit		

General	DRA240-24B	DRA240-48B	DRA240-24A
Switching frequency	approx. 40 kHz		
Insulation voltage input/output	AC 3.0 kV _{eff}		
Insulation voltage input / ground	AC 1.5 kV _{eff}		
Insulation voltage output / ground	–		
Insulation resistance at DC 500 V	100 MΩ		
Operation temperature range	–40 °C – 71 °C (derating)		
Derating	–2.5% / °C starting at 61 °C		
Storage temperature range	–25 °C – 85 °C		
M.T.B.F.	423000 h	437000 h	423000 h
Relative humidity	20–90% RH, non-condensing		

Dimensions (w × h × d) in mm	83.0 × 126 × 116		
Cooling	Natural air cooling, 25 mm distance on all sides		
Housing material	metal		
Shock resistance	–		
Vibration resistance	–		
Field installation	rail TS 35 (EN 50022)		
Application height	4850 m		
Installation position	vertical		
Protection class	IP 20		
IP rating	I (SELV, PELV)		
Overvoltage category	II		
Pollution degree	2		
Weight (kg/piece)	1.000		
Termination	Screw terminal: 0.2–2.5 mm ² - pluggable, max. 0.56 Nm		Screw terminal: 0.2–4.0 mm ² , max. 0.62 Nm

Approvals	UL: UL 508 listed; cUL: UL 60950-1; TÜV: EN 60950, CE: EN 61000-6-3, EN 55022 Class B, EN 61000-3-2, EN 61000-3-3, EN 61000-6-2, EN 55024 Class I, Division 2, Groups A, B, C and D		
-----------	---	--	--

Monitoring	DRA240-24B	DRA240-48B	DRA240-24A
DC ON Control (Rdy)	Normally open	–	Normally open
Switching voltage	DC 60 V	–	DC 60 V
Switching current	max. 300 mA	–	max. 300 mA
Switching capacity	–	–	–
Insulation voltage	DC 500 V	–	DC 500 V

Power supply - regulated, 240 W

Primary switchmode power supply, PFC, Single-phase
Input: wide-range input AC 88–264 V, DC 120–375 V
Output: DC 24 V adjustable



Dimensions

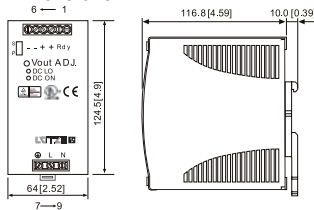

PIN assignment

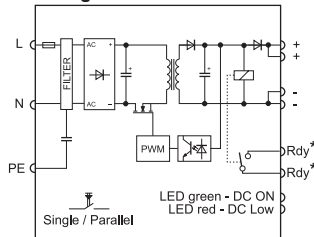

Derating

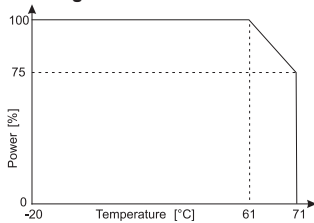

Parallel/redundant mode

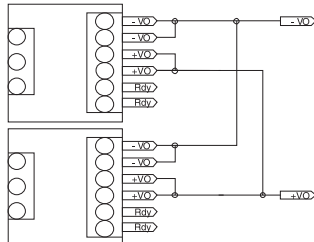

Description	Part-No.	Type	PU	
Screw terminal				
Output voltage/current	DC 24 V; 10 A	722781.1000	DRE240-24A	1
Input				
DRE240-24A				
Nominal voltage	AC 115 / 230 V (auto select)			
Operation voltage range	AC 88 V - 264 V / DC 120 V - 375 V			
Line frequency	47 - 63 Hz			
Rated current	U _i = AC 115 V: 2.3 A / U _i = AC 230 V: 1.15 A			
Inrush current	U _i = AC 115 V: 24 A / U _i = AC 230 V: 48 A			
Internal fuse	T5.0 A / AC 250 V			
External fuse	Mini-circuit breaker: B 10 A, C 6 A			
Power Factor Correction P.F.C.	0.97			
Output				
Rated voltage output	DC 24 V			
Rated current output	10 A			
Max. output current	15 A, 3 s, @ 24 V			
Short-circuit current	-			
Voltage trim range	22.5–28.5 V			
Accuracy	±1 %			
Line regulation	±0.1%			
Load regulation	Single ±1 %, Parallel ±5 %			
Rise time	1 s			
Temperature coefficient	±0.03 % / °C			
Ripple & Noise	100 mV			
Hold up time	V _{in} = 115 V: 25 ms / V _{in} = 230 V: 30 ms			
Status indication DC ON LED green	≥17.6–19.4 V			
Status indication DC LOW LED red	≤17.6–19.4 V			
Parallel/redundant operation	max 3 devices with 90 % load current each, switching with switch S/P			
Efficiency	93 %			
Rated over load protection	120–150 %			
Over voltage protection	125–138 %			
Short circuit characteristics	Hiccup-mode			
General				
Switching frequency	approx. 90 kHz			
Insulation voltage input/output	AC 3.0 kV _{eff}			
Insulation voltage input / ground	AC 1.5 kV _{eff}			
Insulation voltage output / ground	AC 0.5 kV _{eff}			
Insulation resistance at DC 500 V	100 MΩ			
Operation temperature range	-40 °C – 71 °C (derating)			
Derating	-2.5% / °C starting at 61 °C			
Storage temperature range	-40 °C – 85 °C			
M.T.B.F.	410000 h			
Relative humidity	20–90% RH, non-condensing			
Dimensions (w × h × d) in mm	64.0 × 124.5 × 116.6			
Cooling	Natural air cooling, 25 mm distance on all sides			
Housing material	metal			
Field installation	rail TS 35 (EN 50022)			
Application height	4850 m			
Installation position	vertical			
Protection class	IP 20			
IP rating	-			
Overvoltage category	II			
Pollution degree	2			
Weight (kg/piece)	1.000			
Termination	Screw terminal: 0.2–4.0 mm ²			
Approvals	UL: UL 508 listed; cUL: UL 60950-1; TÜV: EN 60950 CE: EN 61000-6-3, EN 55022 Class B EN 61000-3-2, EN 61000-3-3, EN 61000-6-2, EN 55024 EN 61000-4-2 Level 4, EN 61000-4-3 Level 3, EN 61000-4-4 Level 4, EN 61000-4-5 L-N Level 3, L / N-FG Level 4, EN 61000-4-6 Level 3, EN 61000-4-8 Level 4, EN 61000-4-11, ENV 50204 Level 2, EN 61204-3			
Monitoring				
DC ON Control (Rdy)	Normally open			
Switching voltage	DC 60 V			
Switching current	max. 300 mA			
Switching capacity	-			
Insulation voltage	DC 500 V			

Power supply · regulated, 240 W, 3-phase

Primary switchmode power supply, PFC, 3-phase
 Input: wide-range input AC 340–576 V, DC 480–820 V
 Output: 24 / 48 V, adjustable



Dimensions

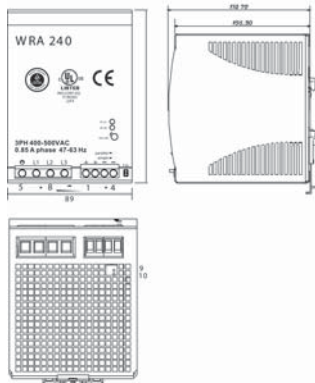

PIN assignment

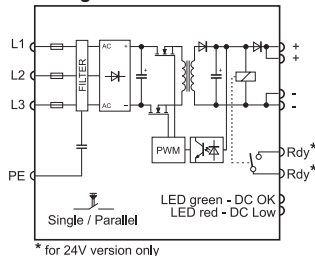

Derating

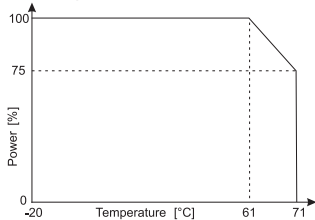

Parallel/redundant mode

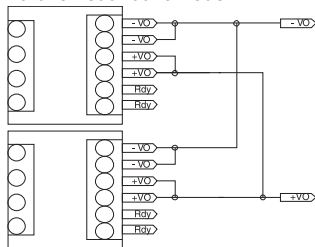

Description	Part-No.	Type	PU	
Screw terminal				
Output voltage/current	DC 24 V/ 10 A	722804	WRA240-24	1
	DC 48 V/ 5 A	722808	WRA240-48	1

Input	WRA240-24	WRA240-48
Nominal voltage	3× AC 340–500 V	
Operation voltage range	3× AC 340–575 V; 3× DC 480–820 V	
Line frequency	47 – 63 Hz	
Rated current	U _I = AC 380 V: 0.85 A / U _I = AC 500 V: 0.7 A	
Inrush current	20 A	
Internal fuse	3×T2, 0 A / AC 600 V	
External fuse	Automatic: 3 × B 6 A	
Power Factor Correction P.F.C.	0.6	

Output	DC 24 V	DC 48 V
Rated voltage output	DC 24 V	DC 48 V
Rated current output	10 A	5 A
Max. output current	–	
Short-circuit current	–	
Voltage trim range	22.5/28.5 V	47/56 V
Accuracy	1 %	
Line regulation	±1 %	
Load regulation	Single ±1 %, Parallel ±5 %	
Rise time	1 s	
Temperature coefficient	±0.03 % / °C	
Ripple & Noise	100 mV	
Hold up time	min. 20 ms	
Status indication DC ON LED green	≥17.6–19.4 V	≥37–43 V
Status indication DC LOW LED red	≤17.6–19.4 V	≤37–43 V
Parallel/redundant operation	max 2 devices with 90 % load current each, switching with switch S/P	
Efficiency	90 %	91 %
Low power loss	30 W (AC 380 V)	24 W (AC 380 V)
Rated over load protection	Temperature: Deactivation at 100–110°C and automatic activation after cooling off	
Over voltage protection	125–137 %	125–142 %
Short circuit characteristics	Hiccup-mode	

General		
Switching frequency	approx. 25 kHz	
Insulation voltage input/output	AC 3.0 kV _{eff}	
Insulation voltage input / ground	AC 1.5 kV _{eff}	
Insulation voltage output / ground	–	
Insulation resistance at DC 500 V	100 MΩ	
Operation temperature range	–25 °C – 71 °C (derating)	
Derating	Capacity: –2.5% / °C starting at +61 °C	
Storage temperature range	–25 °C – 85 °C	
M.T.B.F.	488000 h	519000 h
Relative humidity	20–90% RH, non-condensing	
Dimensions (w × h × d) in mm	89.0 × 123.6 × 117.5	
Cooling	Natural air cooling, 25 mm distance on all sides	
Housing material	Metal	
Shock resistance	–	
Vibration resistance	–	
Field installation	rail TS 35 (EN 50022)	
Application height	3000 m	
Installation position	vertical	
Protection class	IP 20	
IP rating	I (SELV, PELV)	
Overvoltage category	II	
Pollution degree	2	
Weight (kg/piece)	1.100	
Termination	Screw terminal: 0.2–4.0 mm ² , max. 0.62 Nm	

Approvals
 UL: UL 508 listed, cUL: UL 60950-1 accepted, TÜV: EN 60950-1; CE: EN 61000-6-3 / EN 55022 Class B, EN 61000-3-2, EN 61000-3-3, EN 61000-6-2, EN 55024 Class I, Division 2, Groups A, B, C and D

Monitoring		
DC ON Control (Rdy)	Normally open	–
Switching voltage	DC 60 V	–
Switching current	max. 300 mA	–
Switching capacity	–	–
Insulation voltage	DC 500 V	–

Power supply - regulated, 480 W

Primary switchmode power supply, PFC, Single-phase
Input: wide-range input AC 90–264 V, DC 120–370 V
Output: 24 V / 48 V, adjustable



Dimensions

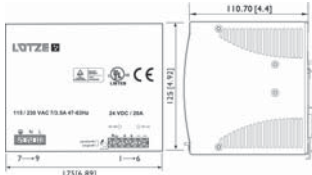

PIN assignment

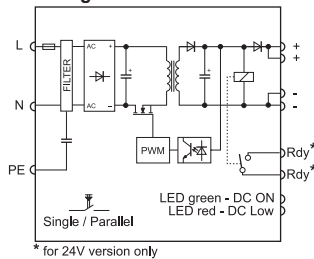

Derating

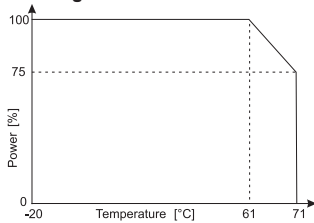

Parallel/redundant mode

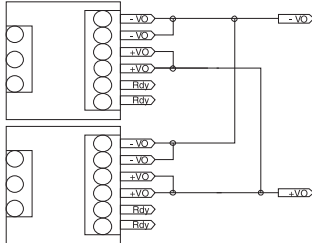

Description	Part-No.	Type	PU	
Screw terminal				
Output voltage/current	DC 24 V / 20 A	722782	DRA480-24A	1
	DC 48 V / 10 A	722779	DRA480-48A	1

Input	DRA480-24A	DRA480-48A
Nominal voltage	AC 115 / 230 V (auto select)	
Operation voltage range	AC 90–264 V; DC 120–370 V	
Line frequency	47 – 63 Hz	
Rated current	U _i = AC 115 V: 4.8 A / U _i = AC 230 V: 2.45 A	
Inrush current	U _i = AC 115 V: 25 A / U _i = AC 230 V: 50 A	
Internal fuse	T10 A / AC 250 V	
External fuse	Mini-circuit breaker: B 16 A	
Power Factor Correction P.F.C.	0.99	

Output	DRA480-24A	DRA480-48A
Rated voltage output	DC 24 V	DC 48 V
Rated current output	20 A	10 A
Max. output current	–	
Short-circuit current	–	
Voltage trim range	22.5–28.5 V	47/56 V
Accuracy	±1 %	
Line regulation	±0.5 %	
Load regulation	Single ±0.5 %, Parallel ±5 %	
Rise time	1 s	
Temperature coefficient	±0.03 % / °C	
Ripple & Noise	100 mV	
Hold up time	min. 30 ms	
Status indication DC ON LED green	≥17.6–19.4 V	≥37–40 V
Status indication DC LOW LED red	≤17.6–19.4 V	≤37–43 V
Parallel/redundant operation	max 3 devices with 90 % load current each, switching with switch S/P	
Efficiency	89 %	90 %
Low power loss	63 W (AC 230 V)	60 W (AC 230 V)
Rated over load protection	120–140 %	
Over voltage protection	125–137 %	119–131 %
Short circuit characteristics	Current limit	

General			
Switching frequency	approx. 60 kHz		
Insulation voltage input/output	AC 3.0 kV _{eff}		
Insulation voltage input / ground	AC 1.5 kV _{eff}		
Insulation voltage output / ground	–		
Insulation resistance at DC 500 V	100 MΩ		
Operation temperature range	-25 °C – 71 °C (derating)		
Derating	-4% / °C starting at 61 °C		
Storage temperature range	-25 °C – 85 °C		
M.T.B.F.	403000 h		416000 h
Relative humidity	20–90% RH, non-condensing		
Dimensions (w × h × d) in mm	175.0 × 125.0 × 116.0		
Cooling	Natural air cooling, 25 mm distance on all sides		
Housing material	metal		
Shock resistance	–		
Vibration resistance	–		
Field installation	rail TS 35 (EN 50022)		
Application height	2000 m		
Installation position	vertical		
Protection class	IP 20		
IP rating	I (SELV, PELV)		
Overvoltage category	II		
Pollution degree	2		
Weight (kg/piece)	1.920		
Termination	Screw terminal: 0.2–4.0 mm ² , max. 0.62 Nm		
Approvals	UL: UL 508 listed; cUL: UL 60950-1 accepted; TÜV: EN 60950-1, CE: EN 61000-6-3 / EN 55022 Class B, EN 61000-3-2, EN 61000-3-3, EN 61000-6-2, EN 55024		

Monitoring			
DC ON Control (Rdy)	Normally open		–
Switching voltage	DC 60 V		–
Switching current	max. 300 mA		–
Switching capacity			–
Insulation voltage	DC 500 V		–

Power supply · regulated, 480 W, 3-phase

Primary switchmode power supply, PFC, 3-phase
Input: wide-range input AC 340–576 V, DC 480–820 V
Output: 24 V / 48 V, adjustable



Dimensions

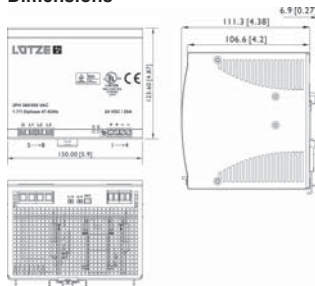

PIN assignment

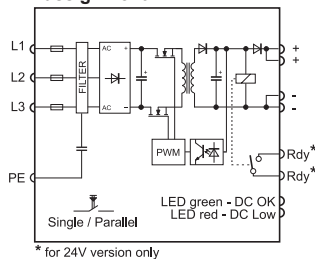

Derating

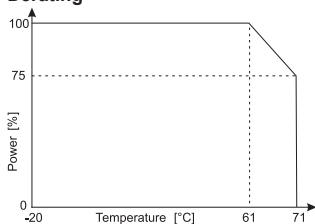

Parallel/redundant mode

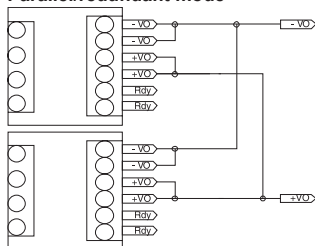

Description	Part-No.	Type	PU	
Screw terminal				
Output voltage/current	DC 24 V / 20 A	722805	WRA480-24	1
	DC 48 V / 10 A	722809	WRA480-48	1

Input	WRA480-24	WRA480-48
Nominal voltage	3× AC 380–500 V	
Operation voltage range	3× AC 340–576 V; 3× DC 480–820 V	
Line frequency	47 – 63 Hz	
Rated current	U _I = AC 400 V: 1.5 A / U _I = AC 480 V: 1.2 A	
Inrush current	20 A	
Internal fuse	T3, 15 A / per phase	
External fuse	Automatic: 3 × B 10 A, C 6 A	
Power Factor Correction P.F.C.	0.7	

Output	DC 24 V	DC 48 V
Rated voltage output	DC 24 V	DC 48 V
Rated current output	20 A	10 A
Max. output current	–	
Short-circuit current	–	
Voltage trim range	22.5 – 28.5 V	47/56 V
Accuracy	1 %	
Line regulation	±1 %	
Load regulation	Single ±1 %, Parallel ±5 %	
Rise time	–	
Temperature coefficient	±0.03 % / °C	
Ripple & Noise	100 mV	
Hold up time	min. 20 ms	
Status indication DC ON LED green	≥17.6–19.4 V	≥37–43 V
Status indication DC LOW LED red	≤17.6–19.4 V	≤37–43 V
Parallel/redundant operation	max 3 devices with 90 % load current each, switching with switch S/P	
Efficiency	90 %	
Low power loss	58 W (AC 380 V)	55 W (AC 380 V)
Rated over load protection	115–135 %	
Over voltage protection	125–137 %	125–142 %
Short circuit characteristics	Current limit (C) / Hiccup-Mode (D); switching with switch C/D Hiccup-Mode: deactivation within 3s and restart after 30s	

General		
Switching frequency	approx. 80 kHz	
Insulation voltage input/output	AC 3.0 kV _{eff}	
Insulation voltage input / ground	AC 1.5 kV _{eff}	
Insulation voltage output / ground	–	
Insulation resistance at DC 500 V	100 MΩ	
Operation temperature range	-25 °C – 71 °C (derating)	
Derating	-2.5% / °C starting at 61 °C	
Storage temperature range	-25 °C – 85 °C	
M.T.B.F.	411000 h	423000 h
Relative humidity	20–90% RH, non-condensing	
Dimensions (w × h × d) in mm	150.0 × 125.0 × 116.0	
Cooling	Natural air cooling, 25 mm distance on all sides	
Housing material	metal	
Shock resistance	–	
Vibration resistance	–	
Field installation	rail TS 35 (EN 50022)	
Application height	3000 m	
Installation position	vertical	
Protection class	IP 20	
IP rating	I (SELV, PELV)	
Overvoltage category	II	
Pollution degree	2	
Weight (kg/piece)	1.750	
Termination	Screw terminal: 0.2–4.0 mm ² , max. 0.62 Nm	
Approvals	UL: UL 508 listed; cUL: UL 60950-1 accepted; TÜV: EN 60950-1; CE: EN 61000-6-3 / EN 55022 Class B, EN 61000-3-2, EN 61000-3-3, EN 61000-6-2, EN 55024	

Monitoring		
DC ON Control (Rdy)	Normally open	–
Switching voltage	DC 60 V	–
Switching current	max. 300 mA	–
Switching capacity	–	–
Insulation voltage	DC 500 V	–

Power supply · regulated, 960 W, 3-phase

Primary switchmode power supply, PFC, 3-phase
Input: wide-range input AC 340–576 V, DC 480–820 V
Output: 24 V / 48 V, adjustable



Dimensions

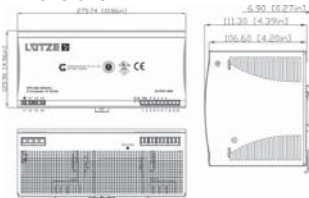

PIN assignment

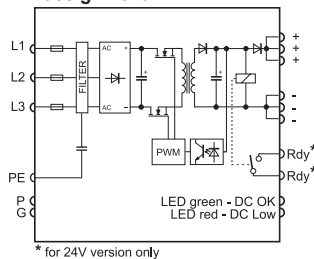

Derating

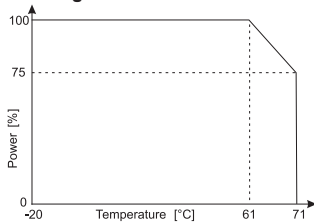

Parallel/redundant mode

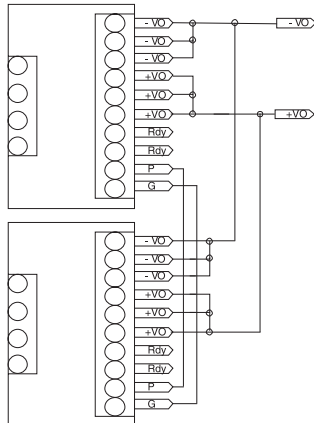

Description	Part-No.	Type	PU	
Screw terminal				
Output voltage/current	DC 24 V / 40 A	722806	WRA960-24	1
	DC 48 V / 20 A	722810	WRA960-48	1

Input	WRA960-24	WRA960-48
Nominal voltage		3× AC 400–500 V
Operation voltage range		3× AC 340–575 V; 3× DC 480–820 V
Line frequency		47 – 63 Hz
Rated current		U _i = AC 400 V: 2.4 A / U _i = AC 480 V: 1.6 A
Inrush current		30 A
Internal fuse		T6, 3 A / per phase
External fuse		Automatic: 3 × B 16 A, C 10 A
Power Factor Correction P.F.C.		0.7

Output	WRA960-24	WRA960-48
Rated voltage output	DC 24 V	DC 48 V
Rated current output	40 A	20 A
Max. output current		–
Short-circuit current		–
Voltage trim range	22.5–28.5 V	47/56 V
Accuracy		1 %
Line regulation		±1 %
Load regulation		Single ±1 %, Parallel ±5 %
Rise time		1 s
Temperature coefficient		±0.03 % / °C
Ripple & Noise		80 mV
Hold up time		15 ms
Status indication DC ON LED green	≥17.6–19.4 V	≥37–43 V
Status indication DC LOW LED red	≤17.6–19.4 V	≤37–43 V
Parallel/redundant operation	max 2 devices with 92 % load current each, connection P and G for distributed current	

Efficiency	92 %	93 %
Low power loss	–	
Rated over load protection	Rated over load protection: 110 % –130 %	
Over voltage protection	125–137 %	125–142 %
Short circuit characteristics	Hiccup-mode	

General		
Switching frequency	approx. 52 kHz	
Insulation voltage input/output	AC 3.0 kV _{eff}	
Insulation voltage input / ground	AC 1.5 kV _{eff}	
Insulation voltage output / ground	–	
Insulation resistance at DC 500 V	100 MΩ	
Operation temperature range	-25 °C – 71 °C (derating)	
Derating	-3.5 % / °C starting at 61 °C	
Storage temperature range	-25 °C – 85 °C	

M.T.B.F.	352000 h	390000 h
Relative humidity	20–90% RH, non-condensing	
Dimensions (w × h × d) in mm	276.0 × 125.0 × 118.0	
Cooling	Natural air cooling, 25 mm distance on all sides	
Housing material	metal	
Shock resistance	–	
Vibration resistance	–	
Field installation	rail TS 35 (EN 50022)	
Application height	3000 m	
Installation position	vertical	
Protection class	IP 20	
IP rating	I (SELV, PELV)	
Overvoltage category	II	
Pollution degree	2	
Weight (kg/piece)	3.200	
Termination	Screw terminal: 0.5–10.0 mm ² , max. 0.62 Nm	
Approvals	UL: UL 508 listed, cUL: UL 60950-1 accepted, TÜV: EN 60950-1; CE: EN 61000-6-3 / EN 55022 Class B, EN 61000-3-2, EN 61000-3-3, EN 61000-6-2, EN 55024 Class I, Division 2, Groups A, B, C and D	

Monitoring		
DC ON Control (Rdy)	Normally open	–
Switching voltage	DC 60 V	–
Switching current	max. 300 mA	–
Switching capacity		–
Insulation voltage	DC 500 V	–

Power supply - Redundant module

Redundant module 20 A with 2 inputs Potential-free signalling contact and Status LED per input Over- and undervoltage control



Dimensions

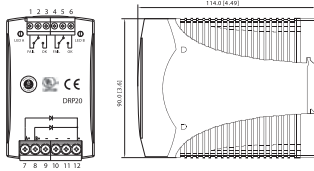

PIN assignment

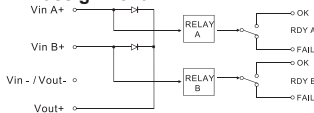

Use

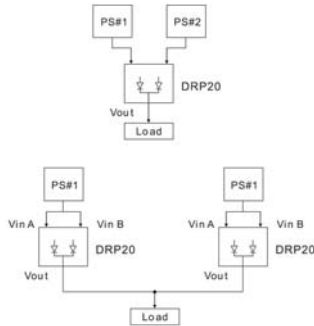

Description	Part-No.	Type	PU	
Screw terminal				
Output voltage/current	DC 24 V/ 20 A	722987	DRP20-24	1
Input				
DRP20-24				
Nominal voltage	DC 24 V			
Operation voltage range	DC 21–28 V			
Inputs	2			
Rated current	max. 20 A in total			
Internal fuse	–			
External fuse	–			
Output				
Rated voltage output	DC 24 V			
Rated current output	20 A			
Max. output current	30 A, 5 s, @ 24 V			
Voltage drop	0.5 V			
Inverse voltage	30 V			
Low power loss	Max. 10 W			
Status indication DC ON LED green	ON: DC input A or B OK / OFF: Error			
Rated over load protection	No			
Over voltage protection	No			
General				
Operation temperature range	-5 °C – 70 °C			
Derating	–			
Storage temperature range	-25 °C – 85 °C			
M.T.B.F.	659000 h			
Dimensions (w × h × d) in mm	54.0 × 90.0 × 114.0			
Cooling	Air convection			
Housing material	Plastic			
Field installation	rail TS 35 (EN 50022)			
Application height	4850 m			
Installation position	vertical			
Protection class	IP 20 (IEC529, EN60529)			
Overvoltage category	II			
Pollution degree	2			
Weight (kg/piece)	0.210			
Termination	Input: screw terminal: 0.2-4.0 mm ² Output: screw terminal: 0.2-6.0 mm ² Relay: screw terminal: 0.2–2.5 mm ²			
Approvals	UL, cUL: UL 508 listed, UL 60950-1 recognised CE: EN 55022 Class B, EN 55024 CE: EN 61000-4-2/3/4/6/8, EN 61204-3			
Monitoring				
DC ON Control (Rdy)	Changeover contact per input No error: input voltage >20 V or <30 V, connection 2(5) - 3(6) closed Error: input voltage <20 V or >30 V, connection 2(5) - 1(4) closed			
Switching voltage	AC 300 V / DC 150 V			
Switching current	AC/DC 1 A			
Switching capacity	300 VA / 30 W			
Insulation voltage	AC 100 V			

COMPACT Power Supplies



COMPACT Series

- One-, two- and three-phase
- 30 W to 2400 W
- Overload current 150 %, 5 sec
- Extremely compact
- Parallel operation
- Overload and short circuit protection
- Redundant operation
- Up to 95% efficiency
- Protection class 1
- UL Listed
- SEMI F47

Power supply · regulated, 40 W

Primary switchmode power supply, PFC, Single-phase, Class 2
Input: wide-range input AC 90–264 V, DC 120–370 V
Output: DC 24 V



Dimensions

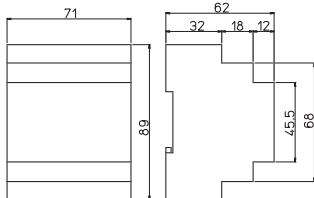

PIN assignment

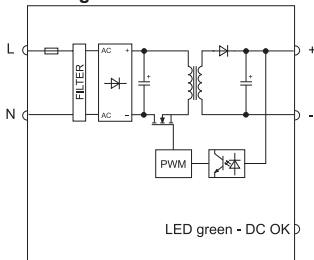

Derating

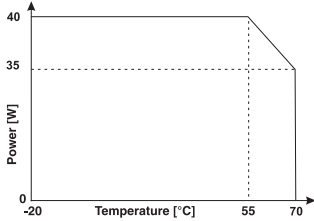

Redundant operation

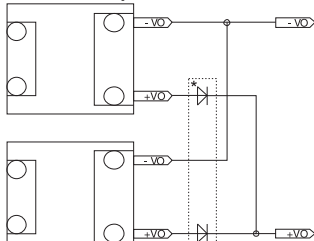

* Redundant Module 722987

Description	Part-No.	Type	PU
Screw terminal			
Output voltage/current	DC 24 V/ 1.2 A	722787	CPSF-1-40-24
			1
Input			
CPSF-1-40-24			
Nominal voltage		AC 115 / 230 V	
Operation voltage range		AC 90–264 V / DC 120–370 V (DC 300 V, UL508)	
Line frequency		47 – 63 Hz	
Rated current		U _i = AC 100 V: 0.90 A / U _i = AC 240 V: 0.50 A	
Inrush current		<30 A	
Internal fuse		T2 A / AC 250 V	
External fuse		Automatic: <4 A	
Power Factor Correction P.F.C.		>0.6	
Output			
Rated voltage output		DC 24 V	
Rated current output		2 A	
Max. output current		3.5 A @ 24 V	
Short-circuit current		–	
Voltage trim range		–	
Accuracy		±1%	
Line regulation		–	
Load regulation		<5 %	
Rise time		–	
Temperature coefficient		–	
Ripple & Noise		<50 mV pp	
Hold up time		>20 ms (AC 120 V); >60 ms (AC 240 V)	
Status indication DC ON LED green		yes	
Status indication DC LOW LED red		No	
Parallel/redundant operation		max. 2 devices / via external diodes	
Efficiency		>85 % (AC 120 V); > 87 % (AC 240 V)	
Low power loss		<6 W	
Rated over load protection		yes	
Over voltage protection		yes	
Short circuit characteristics		Hiccup-mode	
General			
Switching frequency		approx. 110 kHz	
Insulation voltage input/output		AC 3.0 kV _{eff}	
Insulation voltage input / ground		class 2, without PE	
Insulation voltage output / ground		class 2, without PE	
Insulation resistance at DC 500 V		– MΩ	
Operation temperature range		-20 °C – 70 °C (derating)	
Derating		>55°C: -0.35 W / °C	
Storage temperature range		-25 °C – 85 °C	
M.T.B.F.		750000 h to SN29500 / 250000 h to MIL Standard HDBK 217F	
Relative humidity		20–90% RH, non-condensing	
Dimensions (w × h × d) in mm		71.0 × 89.0 × 62.0	
Cooling		Natural air cooling, 10 mm distance right/left, 20 mm distance above/below	
Housing material		Noryl UL 94-0	
Shock resistance		–	
Vibration resistance		–	
Field installation		rail TS 35 (EN 50022)	
Application height		– m	
Installation position		vertical	
Protection class		IP 20 (IEC529, EN60529)	
IP rating		II (SELV, PELV)	
Overvoltage category		II	
Pollution degree		2	
Weight (kg/piece)		0.200	
Termination		Screw terminal: 0.2–2.5 mm ² , max. 0.56 Nm	
Approvals		UL, cUL: UL 508, IEC 950, EN 60950, UL 60950 CE: EN 61000-4-2/3/4/5/6/11, EN 61000-6-2, EN 601000-6-4, EN 50178, EN 61558, EN 61000-3-2, EN 50081-1, EN 50082-2, EN 55022 Class B, EN 55011B	
Monitoring			
DC ON Control (Rdy)		–	
Switching voltage		–	
Switching current		–	
Switching capacity		–	
Insulation voltage		–	

Power supply - regulated, 80 W

Primary switchmode power supply, PFC, Single-phase, Class 2
Input: wide-range input AC 90–264 V, DC 100–345 V
Output: DC 24 V, adjustable



Dimensions

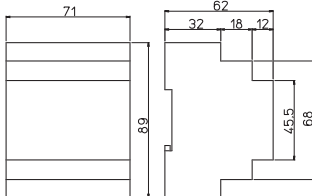

PIN assignment

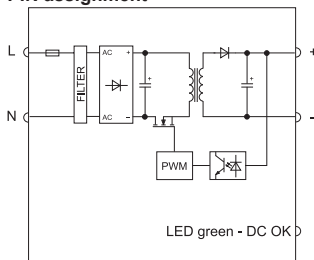

Derating

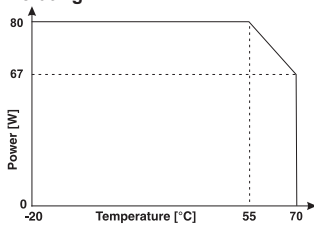

Redundant operation

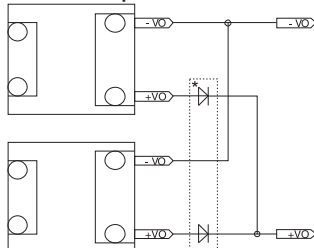

* Redundant Module 722987

Description	Part-No.	Type	PU
Screw terminal			
Output voltage/current	DC 24 V / 3 A	722789	CPSF-1-80-24
			1
Input			
CPSF-1-80-24			
Nominal voltage	AC 115 / 230 V		
Operation voltage range	AC 90–264 V / DC 100–345 V (DC 300 V, UL508)		
Line frequency	47 – 63 Hz		
Rated current	U _I = AC 100 V: 1.40 A / U _I = AC 240 V: 0.85 A		
Inrush current	<30 A		
Internal fuse	T2 A / AC 250 V		
External fuse	Mini-circuit breaker: C 4 A		
Power Factor Correction P.F.C.	>0.6		
Output			
Rated voltage output	DC 24 V		
Rated current output	3.3 A		
Max. output current	4 A @ 24 V		
Short-circuit current	20 A		
Voltage trim range	23.5/27.5 V		
Accuracy	–		
Line regulation	–		
Load regulation	<1 %		
Rise time	–		
Temperature coefficient	–		
Ripple & Noise	<50 mV pp		
Hold up time	>10 ms (AC 120 V); >30 ms (AC 240 V)		
Status indication DC ON LED green	yes		
Status indication DC LOW LED red	No		
Parallel/redundant operation	max. 2 devices / via external diodes		
Efficiency	>87 % (AC 120 V); > 89 % (AC 240 V)		
Low power loss	–		
Rated over load protection	yes		
Over voltage protection	yes		
Short circuit characteristics	Hiccup-mode		
General			
Switching frequency	approx. 70 kHz		
Insulation voltage input/output	AC 3.0 kV _{eff}		
Insulation voltage input / ground	class 2, without PE		
Insulation voltage output / ground	class 2, without PE		
Insulation resistance at DC 500 V	– MΩ		
Operation temperature range	–20 °C – 70 °C (derating) (55°C UL508)		
Derating	>55 °C: –0.9 W / °C		
Storage temperature range	–25 °C – 85 °C		
M.T.B.F.	750000 h to SN29500 / 250000 h to MIL Standard HDBK 217F		
Relative humidity	20–90% RH, non-condensing		
Dimensions (w × h × d) in mm	71.0 × 89.0 × 62.0		
Cooling	Natural air cooling, 10 mm distance right/left, 20 mm distance above/below		
Housing material	Noryl UL 94-0		
Shock resistance	–		
Vibration resistance	–		
Field installation	rail TS 35 (EN 50022)		
Application height	– m		
Installation position	vertical		
Protection class	IP 20 (IEC529, EN60529)		
IP rating	II (SELV, PELV)		
Overvoltage category	II		
Pollution degree	2		
Weight (kg/piece)	0.250		
Termination	Screw terminal: 0.2–2.5 mm ² , max. 0.56 Nm		
Approvals	UL, cUL: UL 508, IEC 950, EN 60950, UL 60950 CE: EN 61000-4-2/3/4/5/6/11, EN 61000-6-2, EN 601000-6-4, EN 50178, EN 61558, EN 61000-3-2, EN 50081-1, EN 50082-2, EN 55022 Class B, EN 55011B		
Monitoring			
DC ON Control (Rdy)	–		
Switching voltage	–		
Switching current	–		
Switching capacity	–		
Insulation voltage	–		

Power supply · regulated, 120 W

Primary switchmode power supply, PFC, Single-phase
Input: wide-range input AC 90–264 V, DC 110–345 V
Output: 24 V, adjustable



Dimensions

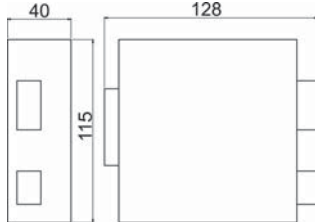

PIN assignment

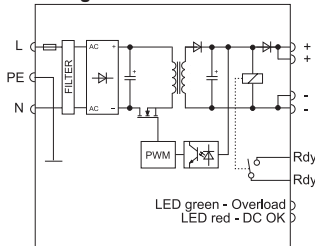

Derating

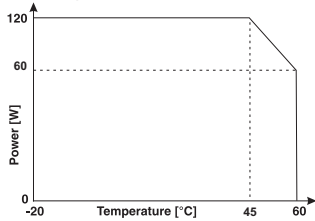

Parallel mode

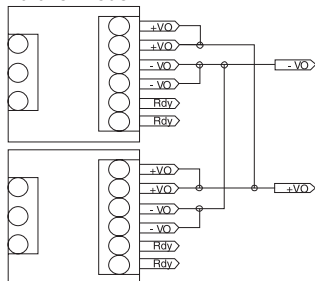

Description	Part-No.	Type	PU	
Screw terminal				
Output voltage/current	DC 24 V / 5 A	722783	CPSB1-120-24R	1
	DC 48 V / 2.5 A	722784	CPSB1-120-48R	1

Input	CPSB1-120-24R	CPSB1-120-48R
Nominal voltage	AC 120 V / 230 V	
Operation voltage range	AC 90–264 V / DC 110–345 V	
Line frequency	47 – 63 Hz	
Rated current	$U_i = AC 115 V: 1.9 A / U_i = AC 230 V: 1.1 A$	
Inrush current	<20 A	
Internal fuse	T3, 15 A / AC 250 V	
External fuse	Mini-circuit breaker: B 6 A, C 4 A	
Power Factor Correction P.F.C.	>0.65	

Output	CPSB1-120-24R	CPSB1-120-48R
Rated voltage output	DC 24 V	DC 48 V
Rated current output	5 A	2.5 A
Max. output current	9 A, 30 s, @ 24 V	4 A, 30 s, @ 24 V
Short-circuit current	15 A, 50 ms	
Voltage trim range	DC 23–27.5 V	DC 45–55 V

Accuracy	–	
Line regulation	–	
Load regulation	<1 %	
Rise time	–	
Temperature coefficient	–	
Ripple & Noise	<30 mV	
Hold up time	>16 ms (AC 120 V), >81 ms (AC 230 V)	
Status indication DC ON LED green	≥21.6 V	≥43.2 V
Status indication DC LOW LED red	≤21.6 V	≤43.2 V
Parallel/redundant operation	max. 2 devices / via internal diodes	
Efficiency	>86 %	
Low power loss	<20 W	
Rated over load protection	yes	
Over voltage protection	yes	
Short circuit characteristics	Hiccup-mode	

General	
Switching frequency	approx. 110 kHz
Insulation voltage input/output	AC 3.0 kV _{eff}
Insulation voltage input / ground	AC 1.5 kV _{eff}
Insulation voltage output / ground	AC 0.5 kV _{eff}
Insulation resistance at DC 500 V	– MΩ
Operation temperature range	–20 °C – 60 °C (derating)
Derating	>45 °C: –4 W / °C
Storage temperature range	–25 °C – 85 °C
M.T.B.F.	>500000 h to SN29500 / >150000 h to MIL standard HDBK 217F
Relative humidity	20–90% RH, non-condensing
Dimensions (w × h × d) in mm	40.0 × 115.0 × 128.0

Cooling	Natural air cooling, 10 mm distance right/left, 50 mm distance above/below
Housing material	Aluminum
Shock resistance	30 g 6 ms, 20 g 11 ms, 3 shocks / direction, 18 shocks in total, IEC60068-2-27:2008
Vibration resistance	5 – 17.8 Hz: ±1.6 mm, 17.8 – 500 Hz: 2 g 2 hours / axes X,Y,Z, IEC 60068-2-6:2007
Field installation	rail TS 35 (EN 50022)
Application height	– m
Installation position	vertical
Protection class	IP 20 (IEC529, EN60529)
IP rating	I (SELV, PELV)
Overvoltage category	II
Pollution degree	2
Weight (kg/piece)	0.400
Termination	Screw terminal: 0.2–2.5 mm ² - pluggable,max. 0.56 Nm
Approvals	UL, cUL: UL 508, IEC 950, EN 60950, UL 60950 CE: EN 61000-4-2/3/4/5/6/11, EN 61000-6-2, EN 601000-6-4, EN 50178, EN 61558, EN 50081-1, EN 50082-2, EN 55022 Class B

Monitoring	
DC ON Control (Rdy)	Normally open
Switching voltage	AC 300 V / DC 150 V
Switching current	AC/DC 1 A
Switching capacity	300 VA / 30 W
Insulation voltage	AC 500 V

Power supply - regulated, 120 W

Primary switched power supplies, PFC, 1/2-phase
Input: wide-range input AC 187–550 V, DC 270–725 V
Output: 24 V, adjustable

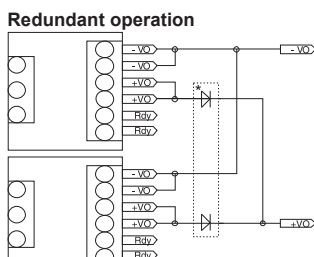
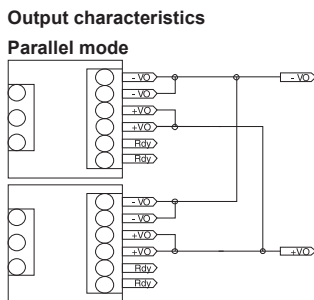
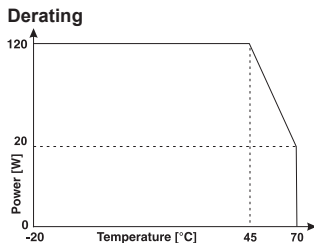
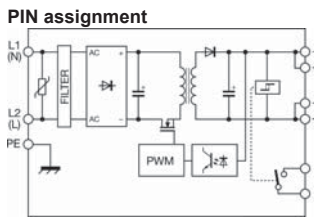
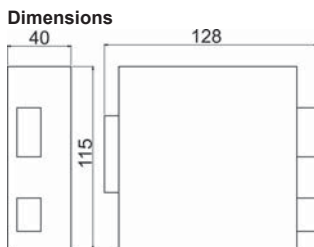

* Redundant Module 722987

Description	Part-No.	Type	PU	
Screw terminal, pluggable				
Output voltage/current	DC 24 V / 5 A	722995	CPSB2-120-24	1
Input				
CPSB2-120-24				
Nominal voltage	AC 200–500 V			
Operation voltage range	AC 187–550 V / DC 270–725 V			
Line frequency	47 – 63 Hz			
Rated current	U _i = AC 200 V: 1.4 A / U _i = AC 500 V: 0.7 A			
Inrush current	<20 A (AC 230 V), <40 A (AC 500 V)			
Internal fuse	–			
External fuse	Automatic: D 6 A, C 6 A / safety fuse: T 4 A (required)			
Power Factor Correction P.F.C.	>0.55			
Output				
Rated voltage output	DC 24 V			
Rated current output	5 A @ 45 °C			
Max. output current	>7.5 A, >30 sec			
Short-circuit current	>14 A, 400 ms			
Voltage trim range	23-27.5 V			
Accuracy	–			
Line regulation	–			
Load regulation	<1 %			
Rise time	9 ms (5–95 %) @ 400 V			
Temperature coefficient	–			
Ripple & Noise	<100 mV pp			
Hold up time	>20 ms (AC 120 V), >80 ms (AC 230 V)			
Status indication DC ON LED green	≥21.6 V			
Status indication DC LOW LED red	I _{out} > 110 % I _N			
Parallel/redundant operation	yes/via external decoupling diode			
Efficiency	>86 %			
Low power loss	<18 W			
Rated over load protection	yes			
Over voltage protection	U _{out} >36 V			
Short circuit characteristics	Hiccup-mode			
General				
Switching frequency	–			
Insulation voltage input/output	AC 3.0 kV _{eff}			
Insulation voltage input / ground	AC 2.0 kV _{eff}			
Insulation voltage output / ground	AC 0.5 kV _{eff}			
Insulation resistance at DC 500 V	– MΩ			
Operation temperature range	-20 °C – 70 °C (overtemperature protection)			
Derating	>45 °C: -4 W / °C			
Storage temperature range	-25 °C – 85 °C			
M.T.B.F.	>500000 h to SN29500 / >150000 h to MIL standard HDBK 217F			
Relative humidity	20–90% RH, non-condensing			
Dimensions (w × h × d) in mm	40.0 × 130.0 × 115.0			
Cooling	Air convection			
Housing material	Aluminum			
Shock resistance	30 g 6 ms, 20 g 11 ms, 3 shocks / direction, 18 shocks in total, IEC60068-2-27:2008			
Vibration resistance	5 – 17.8 Hz: ±1.6 mm, 17.8 – 500 Hz: 2 g 2 hours / axes X,Y,Z, IEC 60068-2-6:2007			
Field installation	rail TS 35 (EN 50022)			
Application height	2000 m			
Installation position	vertical			
Protection class	IP 20 (IEC529, EN60529)			
IP rating	I (SELV, PELV)			
Overvoltage category	II (IEC 664-1)			
Pollution degree	2			
Weight (kg/piece)	0.400			
Termination	Screw terminal: 0.2–2.5 mm ² (AWG 24–12) - pluggable			
Approvals	UL, cUL: UL 508, IEC 60950 CE: EN 60950, EN 61000-6-2 (2005), EN 60100-6-4 (2007), EN 61000-4-2/3/4/5/6/11, EN 61000-5-5			
Monitoring				
DC ON Control (Rdy)	yes			
Switching voltage	AC/DC 300 V / DC 150 V			
Switching current	AC/DC 1 A			
Switching capacity	300 VA / 30 W			
Insulation voltage	AC 500 V			

Power supply · regulated, 240 W

Primary switchmode power supply, PFC, Single-phase
Input: AC 90–132 V, AC 187–264 V, DC 270–345 V
Output: 24 V, adjustable



Dimensions

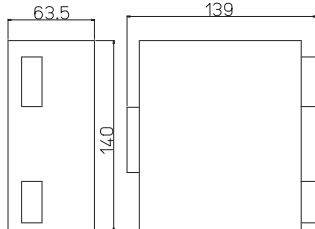

PIN assignment

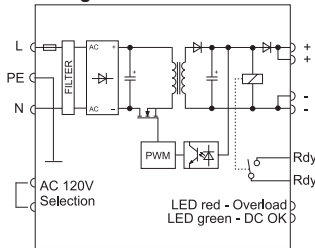

Derating

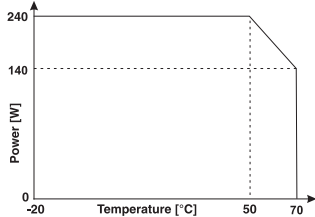

Parallel/redundant mode

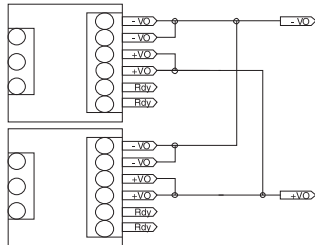

Description	Part-No.	Type	PU	
Screw terminal, pluggable				
Output voltage/current	DC 24 V; 10 A	722785	CPSB1-240-24R	1
	DC 48 V; 5 A	722786	CPSB1-240-48R	1
Input				
	CPSB1-240-24R		CPSB1-240-48R	
Nominal voltage	AC 120 / 230 V (manual)			
Operation voltage range	AC 90–132 V, AC 187–264 V, DC 270–345 V			
Line frequency	47 – 63 Hz			
Rated current	U _i = AC 115 V: 4 A / U _i = AC 230 V: 2 A			
Inrush current	U _i = AC 115 V: 30 A / U _i = AC 230 V: 35 A			
Internal fuse	T6, 3 A / AC 250 V			
External fuse	Mini-circuit breaker: C 10 A			
Power Factor Correction P.F.C.	>0.6			
Output				
Rated voltage output	DC 24 V	DC 48 V		
Rated current output	10 A	5 A		
Max. output current	13.5 A, 30 s, @ 24 V	6.9 A, 30 s, @ 24 V		
Short-circuit current	35 A, 150 ms	20 A, 160 ms		
Voltage trim range	23/27.5 V	45/55 V		
Accuracy	–			
Line regulation	–			
Load regulation	1 %			
Rise time	–			
Temperature coefficient	–			
Ripple & Noise	100 mV			
Hold up time	>80 ms (120 V), >90 ms (230 V)			
Status indication DC ON LED green	≥21.6 V	≥43.2 V		
Status indication DC LOW LED red	≤21.6 V	≤43.2 V		
Parallel/redundant operation	max. 2 devices / via internal diodes			
Efficiency	89 %	90 %		
Low power loss	<35 W	<34 W		
Rated over load protection	yes			
Over voltage protection	yes			
Short circuit characteristics	Hiccup-mode			
General				
Switching frequency	approx. 110 kHz			
Insulation voltage input/output	AC 3.0 kV _{eff}			
Insulation voltage input / ground	AC 1.5 kV _{eff}			
Insulation voltage output / ground	AC 0.5 kV _{eff}			
Insulation resistance at DC 500 V	– MΩ			
Operation temperature range	–20 °C – 70 °C (derating)			
Derating	>50 °C: –5 W / °C			
Storage temperature range	–25 °C – 85 °C			
M.T.B.F.	>500000 h to SN29500 / >150000 h to MIL standard HDBK 217F			
Relative humidity	20–90% RH, non-condensing			
Dimensions (w × h × d) in mm	63.5 × 140.0 × 139.0			
Cooling	Natural air cooling, 20 mm distance right/left, 100 mm distance above/below			
Housing material	Aluminum			
Shock resistance	30 g 6 ms, 20 g 11 ms, 3 shocks / direction, 18 shocks in total, IEC60068-2-27:2008			
Vibration resistance	5 – 17.8 Hz: ±1.6 mm, 17.8 – 500 Hz: 2 g 2 hours / axes X,Y,Z, IEC 60068-2-6:2007			
Field installation	rail TS 35 (EN 50022)			
Application height	– m			
Installation position	vertical			
Protection class	IP 20 (IEC529, EN60529)			
IP rating	I (SELV, PELV)			
Overvoltage category	III			
Pollution degree	2			
Weight (kg/piece)	0.720			
Termination	Screw terminal: 0.2–2.5 mm ² - pluggable,max. 0.56 Nm			
Approvals	UL, cUL: UL 508, IEC 950, EN 60950, UL 60950 CE: EN 61000-4-2/3/4/5/6/11, EN 61000-6-2, EN 601000-6-4, EN 50178, EN 61558, EN 50081-1, EN 50082-2, EN 55022 Class B			
Monitoring				
DC ON Control (Rdy)	Normally open			
Switching voltage	AC 300 V / DC 150 V			
Switching current	AC/DC 1 A			
Switching capacity	300 VA / 30 W			
Insulation voltage	AC 500 V			

Power supply - regulated, 240 W

Primary switched power supplies, PFC, 1/2/3-phase

Input: wide-range input AC 187–550 V, DC 250–725 V (UL: DC 300–500 V)

Output: 24 V, adjustable



Dimensions

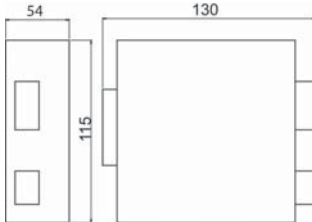

PIN assignment

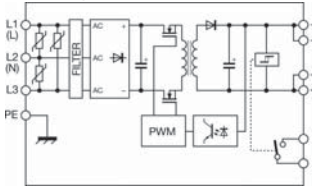

Derating

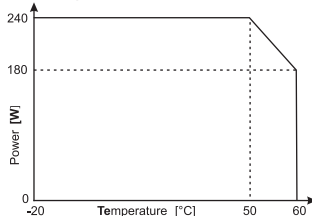

Output characteristics

Redundant operation

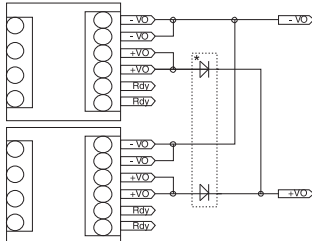

* Redundant Module 722987

Description	Part-No.	Type	PU
Screw terminal, pluggable			
Output voltage/current	DC 24 V/ 10 A	722996	CPSB-123-240-24
Input			
CPSB-123-240-24			
Nominal voltage	AC 200–500 V		
Operation voltage range	AC 187–550 V / DC 250–725 V (UL: DC 300–500 V)		
Line frequency	47 – 63 Hz		
Rated current	1-1/2-phase @ AC 220 V: 2.2 A, 1-1/2-phase @ AC 500 V: 1.1 A 3-phase @ AC 220 V: 1.5 A, 3-phase @ AC 500 V: 0.8 A		
Inrush current	<20 A (AC 230 V), <40 A (AC 500 V)		
Internal fuse	–		
External fuse	Automatic: D 4 A, C 6 A / safety fuse: T 6.3 A (required)		
Power Factor Correction P.F.C.	>0.60 @ AC 230 V, >0.5 @ AC 400 V		
Output			
Rated voltage output	DC 24 V		
Rated current output	10 A		
Max. output current	>15 A, 5 s		
Short-circuit current	38 A, 5 s		
Voltage trim range	23-27,5 V		
Accuracy	–		
Line regulation	–		
Load regulation	<1 %		
Rise time	14 ms (5–95 %) @ 400 V		
Temperature coefficient	–		
Ripple & Noise	<100 mV pp		
Hold up time	>15 ms (AC 230 V), >100 ms (AC 500 V)		
Status indication DC ON LED green	≥21.6 V		
Status indication DC LOW LED red	≤21.6 V		
Parallel/redundant operation	yes/with external decoupling diode		
Efficiency	>91 % @ AC 230 V, >92% @ AC 400 V		
Low power loss	<24 W @ AC 230 V, <21 W @ AC 400 V		
Rated over load protection	yes		
Over voltage protection	> DC 33 V		
Short circuit characteristics	Hiccup-mode		
General			
Switching frequency	–		
Insulation voltage input/output	AC 3.0 kV _{eff}		
Insulation voltage input / ground	AC 2.0 kV _{eff}		
Insulation voltage output / ground	AC 0.5 kV _{eff}		
Insulation resistance at DC 500 V	– MΩ		
Operation temperature range	-20 °C – 60 °C (overtemperature protection)		
Derating	-6 W/°C from +50 °C		
Storage temperature range	-25 °C – 85 °C		
M.T.B.F.	>500000 h to SN29500 / >150000 h to MIL standard HDBK 217F		
Relative humidity	20–90% RH, non-condensing		
Dimensions (w × h × d) in mm	54.0 × 130.0 × 115.0		
Cooling	Air convection 20 mm clearance right/left, 50 mm clearance up/down		
Housing material	Aluminum		
Shock resistance	30 g 6 ms, 20 g 11 ms, 3 shocks / direction, 18 shocks in total, IEC60068-2-27:2008		
Vibration resistance	5 – 17.8 Hz: ±1.6 mm, 17.8 – 500 Hz: 2 g 2 hours / axes X,Y,Z, IEC 60068-2-6:2007		
Field installation	rail TS 35 (EN 50022)		
Application height	2000 m		
Installation position	vertical		
Protection class	IP 20 (IEC529, EN60529)		
IP rating	I (SELV, PELV)		
Overtoltage category	II (IEC 664-1)		
Pollution degree	2		
Weight (kg/piece)	0.650		
Termination	Screw terminal: 0.2–2.5 mm ² (AWG 30–12) - pluggable		
Approvals	UL, cUL: UL 508, IEC 60950 CE: EN 60950, EN 61000-6-2 (2005), EN 60100-6-4 (2007), EN 61000-4-2/3/4/5/6/11, EN 61000-5-5 EN 55011 (conducted emission class B, radiated emission class A)		
Monitoring			
DC ON Control (Rdy)	Change over contact		
Switching voltage	DC 30 V		
Switching current	DC 1 A		
Switching capacity	30 W		
Insulation voltage	AC 500 V		

Power supply · regulated, 480 W

Primary switchmode power supply, PFC, Single-phase
Input: AC 90–132 V, AC 187–264 V
Output: 24 V, adjustable



Dimensions

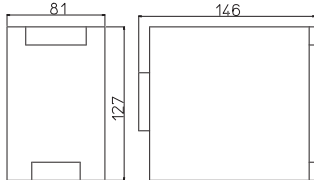

PIN assignment

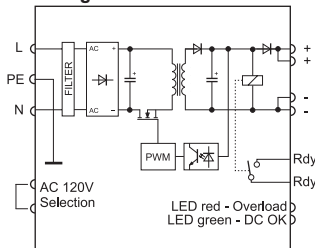

Derating

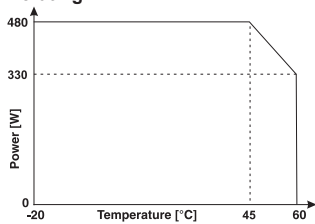

Parallel/redundant mode

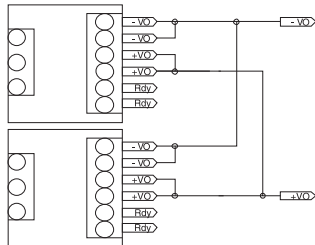

Description	Part-No.	Type	PU	
Screw terminal				
Output voltage/current	DC 24 V/ 20 A	722986	CPSB1-480-24R	1
	DC 48 V/ 10 A	722989	CPSB1-480-48R	1

Input	CPSB1-480-24R	CPSB1-480-48R
Nominal voltage	AC 120 V / AC 240 V	
Operation voltage range	AC 90–132 V / AC 187–264 V	
Line frequency	47 – 63 Hz	
Rated current	$U_1 = AC 120 V: 7.2 A / U_1 = AC 230 V: 4.3 A$	
Inrush current	<13 A	
Internal fuse	–	
External fuse	Automatic: C 16 A (required)	
Power Factor Correction P.F.C.	>0.6	

Output	CPSB1-480-24R	CPSB1-480-48R
Rated voltage output	DC 24 V	DC 48 V
Rated current output	20 A	10 A
Max. output current	30 A, 5 s, @ 24 V	15 A, 5 s, @ 48 V
Short-circuit current	30 A (>50 A Hiccup)	15 A (>40 A Hiccup)
Voltage trim range	23/28 V	45/55 V
Accuracy	–	
Line regulation	–	
Load regulation	<1 %	
Rise time	–	
Temperature coefficient	–	
Ripple & Noise	100 mV pp	
Hold up time	>35 ms (AC 240 V)	
Status indication DC ON LED green	$\geq 21.6 V$	$\geq 43.2 V$
Status indication DC LOW LED red	$\leq 21.6 V$	$\leq 43.2 V$
Parallel/redundant operation	max. 4 devices / via internal diodes	
Efficiency	>92 % (AC 240 V)	
Low power loss	<45 W (AC 230 V)	
Rated over load protection	yes	
Over voltage protection	yes	
Short circuit characteristics	Hiccup–mode / Constant current	

General	
Switching frequency	approx. 70 – 110 kHz
Insulation voltage input/output	AC 3.0 kV _{eff}
Insulation voltage input / ground	AC 2.0 kV _{eff}
Insulation voltage output / ground	AC 0.7 kV _{eff}
Insulation resistance at DC 500 V	– MΩ
Operation temperature range	–20 °C – 60 °C (derating)
Derating	>45 °C: –10 W / °C
Storage temperature range	–25 °C – 85 °C
M.T.B.F.	750000 h to SN29500 / 250000 h to MIL Standard HDBK 217F
Relative humidity	20–90% RH, non-condensing
Dimensions (w × h × d) in mm	81.0 × 127.0 × 146.0
Cooling	Natural air cooling, 10 mm distance right/left, 50 mm distance above/below
Housing material	Aluminum
Shock resistance	30 g 6 ms, 20 g 11 ms, 3 shocks / direction, 18 shocks in total, IEC60068-2-27:2008
Vibration resistance	5 – 17.8 Hz: $\pm 1.6 mm$, 17.8 – 500 Hz: 2 g 2 hours / axes X,Y,Z, IEC 60068-2-6:2007
Field installation	rail TS 35 (EN 50022)
Application height	– m
Installation position	vertical
Protection class	IP 20 (IEC529, EN60529)
IP rating	I (SELV, PELV)
Overvoltage category	II
Pollution degree	2
Weight (kg/piece)	1.100
Termination	Screw terminal: 0.2–6.0 mm ² , max. 0.62 Nm
Approvals	UL, cUL: UL 508, IEC 950, EN 60950 CE: EN 61000-4-2/3/4/5/6/11, EN 61000-6-2, EN 61000-6-4, EN 50178, EN 61558, EN 50081-1, EN 50082-2, EN 55022 Class B

Monitoring	
DC ON Control (Rdy)	Normally open
Switching voltage	AC 300 V / DC 150 V
Switching current	AC/DC 1 A
Switching capacity	300 VA / 30 W
Insulation voltage	AC 500 V

Power supply - regulated, 480 W

Primary switched power supplies, PFC, 1/2/3-phase

Input: wide-range input AC 187–550 V, DC 250–725 V (UL: DC 300–500 V)

Output: 24 V, adjustable



Dimensions

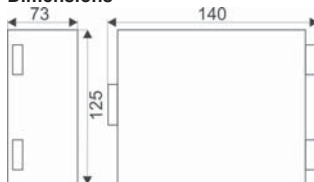

PIN assignment

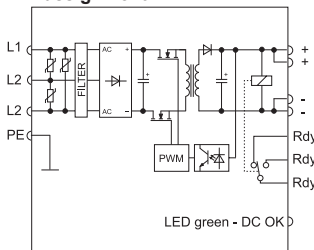

Derating

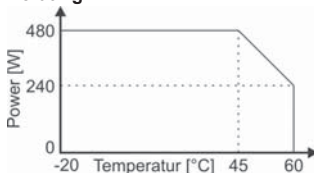

Redundant operation

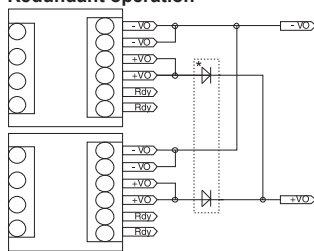

* Redundant Module 722987

Description	Part-No.	Type	PU	
Screw terminal, pluggable				
Output voltage/current	DC 24 V; 20 A	722801	CPSB-123-480-24	1
Input				
CPSB-123-480-24				
Nominal voltage	One-, two- and three-phase AC 200-500 V			
Operation voltage range	AC 187–550 V / DC 250–725 V (UL: DC 300–500 V)			
Line frequency	47 – 63 Hz			
Rated current	1-,2-phase @ AC 200 V: 2,9 A / 1-,2-phase @ AC 500 V: 1,3 A 3-phase @ AC 200 V: 1,8 A / 3-phase @ AC 500 V: 0,8 A			
Inrush current	U _i = AC 230 V: <20 A / U _i = AC 400 V: <40 A			
Internal fuse	–			
External fuse	Automatic: C 6 A, oder D 4 A (required)			
Power Factor Correction P.F.C.	U _i = AC 230 V: <0.95 A / U _i = AC 400 V: <0.92 A			
Output				
Rated voltage output	DC 24 V			
Rated current output	20 A			
Max. output current	28 A, 5 s			
Short-circuit current	50 A			
Voltage trim range	23-27,5 V			
Load regulation	<1 %			
Rise time	–			
Temperature coefficient	–			
Ripple & Noise	≤100 mV pp			
Hold up time	>20 ms			
Status indication DC ON LED green	≥21.6 V			
Status indication DC LOW LED red	I _{out} >1.1 I _N			
Parallel/redundant operation	yes/via external decoupling diode			
Efficiency	>92 %			
Low power loss	<21 W			
Over voltage protection	<DC 33 V			
Overtemperature protection	yes			
Short circuit characteristics	Hiccup-mode			
General				
Insulation voltage input/output	DC 4,2 kV			
Insulation voltage input / ground	DC 2.2 kV			
Insulation voltage output / ground	DC 0.75 kV			
Operation temperature range	-20 °C – 60 °C (derating)			
Derating	<45 °C: -16 W/°C			
Storage temperature range	-25 °C – 85 °C			
M.T.B.F.	>500000 h to SN29500 / >150000 h to MIL standard HDBK 217F			
Dimensions (w × h × d) in mm	73.0 × 125.0 × 140.0			
Cooling	Natural air cooling			
Housing material	Aluminum			
Shock resistance	30 g 6 ms, 20 g 11 ms, 3 shocks / direction, 18 shocks in total, IEC60068-2-27:2008			
Vibration resistance	5 – 17.8 Hz: ±1.6 mm, 17.8 – 500 Hz: 2 g 2 hours / axes X,Y,Z, IEC 60068-2-6:2007			
Field installation	rail TS 35 (EN 50022)			
Installation position	vertical			
Protection class	IP 20 (IEC529, EN60529)			
Overtoltage category	II			
Pollution degree	2			
Weight (kg/piece)	1.000			
Termination	Screw terminal: 0.2–2.5 mm ² (AWG 24–12) - pluggable			
Approvals	UL, cUL: UL 508C, IEC 950, EN 60950 CE: EN 61000-6-2, EN 61000-6-4, EN 55011, EN 6100-4-2 CE: EN 61000-4-3/4/5/6/11			
Monitoring				
DC ON Control (Rdy)	Normally open			
Switching voltage	AC/DC 30 V			
Switching current	AC/DC 1 A			
Switching capacity	30 VA / 30 W			
Insulation voltage	AC 500 V			

Power supply · regulated, 480 W, 3-phase

Primary switchmode power supply, PFC, 3-phase
Input: Wide range input AC 340 - 550 V
Output: 24 V, adjustable



Dimensions

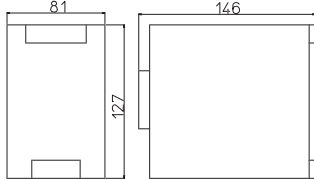

PIN assignment

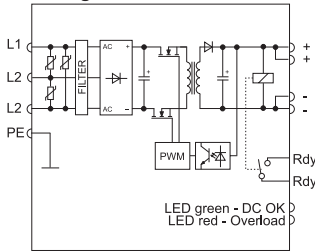

Derating

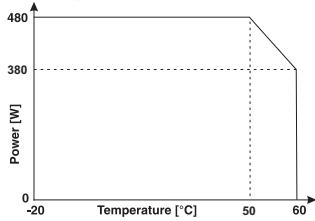

Redundant operation

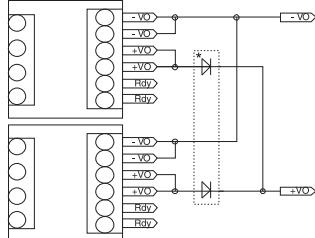

* Redundant Module 722987

Description	Part-No.	Type	PU	
Screw terminal				
Output voltage/current	DC 24 V / 20 A	722800	CPSB3-500-24	1
	DC 48 V / 10 A	722815	CPSB3-500-48	1

Input	CPSB3-500-24	CPSB3-500-48
Nominal voltage	3× AC 400–500 V	
Operation voltage range	3× AC 340–550 V	
Line frequency	47 – 63 Hz	
Rated current	U _I = AC 400 V: 1.3 A / U _I = AC 500 V: 1.1 A	
Inrush current	<50 A	
Internal fuse	–	
External fuse	Automatic: 3 × B 16 A, C 10 A (required)	
Power Factor Correction P.F.C.	>0.6	

Output	CPSB3-500-24	CPSB3-500-48
Rated voltage output	DC 24 V	DC 48 V
Rated current output	20 A	10 A
Max. output current	–	
Short-circuit current	30 A (>60 A Hiccup)	15 A
Voltage trim range	24/28 V	45-55 V
Accuracy	–	
Line regulation	–	
Load regulation	<1 %	
Rise time	–	
Temperature coefficient	–	
Ripple & Noise	100 mV pp	<100 mV pp
Hold up time	>20 ms (AC 400 V)	
Status indication DC ON LED green	≥21.6 V	
Status indication DC LOW LED red	≤21.6 V	
Parallel/redundant operation	max. 2 devices / via external diodes	max. 4 devices / via external diodes
Efficiency	>94 % (AC 400 V)	
Low power loss	<30 W (AC 380 V)	<15 W (AC 380 V)
Rated over load protection	yes	
Over voltage protection	yes	
Short circuit characteristics	Hiccup–mode / Constant current	

General		
Switching frequency	approx. 70 – 110 kHz	
Insulation voltage input/output	AC 3.0 kV _{eff}	
Insulation voltage input / ground	AC 2.0 kV _{eff}	
Insulation voltage output / ground	AC 1.0 kV _{eff}	
Insulation resistance at DC 500 V	– MΩ	
Operation temperature range	–20 °C – 60 °C (derating)	
Derating	>50 °C: –10 W / °C	
Storage temperature range	–25 °C – 85 °C	
M.T.B.F.	>500000 h to SN29500 / >150000 h to MIL standard HDBK 217F	
Relative humidity	20–90% RH, non-condensing	
Dimensions (w × h × d) in mm	81.0 × 127.0 × 146.0	
Cooling	Air convection 20 mm clearance right/left, 50 mm clearance up/down	
Housing material	Aluminum	
Shock resistance	30 g 6 ms, 20 g 11 ms, 3 shocks / direction, 18 shocks in total, IEC60068-2-27:2008	
Vibration resistance	5 – 17.8 Hz: ±1.6 mm, 17.8 – 500 Hz: 2 g 2 hours / axes X,Y,Z, IEC 60068-2-6:2007	
Field installation	Snaps on to TS 35 rail (EN 60175)	
Application height	– m	
Installation position	vertical	
Protection class	IP 20 (IEC529, EN60529)	
IP rating	I (SELV, PELV)	
Overvoltage category	II	
Pollution degree	2	
Weight (kg/piece)	1.200	
Termination	Screw terminal: 0.2–6.0 mm ² , max. 0.62 Nm	
Approvals	UL, cUL: UL 508, IEC 950, EN 60950 CE: EN 61000-4-2/3/4/5/6/11, EN 61000-6-2, EN 61000-6-4, EN 50178, EN 61558, EN 50081-1, EN 50082-2, EN 55022 Class B	

Monitoring		
DC ON Control (Rdy)	Normally open	
Switching voltage	AC 300 V / DC 150 V	
Switching current	AC/DC 1 A	
Switching capacity	300 VA / 30 W	
Insulation voltage	AC 500 V	

Power supply · regulated, 720 W, 3-phase

Primary switchmode power supply, PFC, 3-phase
Input: Wide range input AC 340 - 550 V
Output: 24 V, adjustable



Dimensions

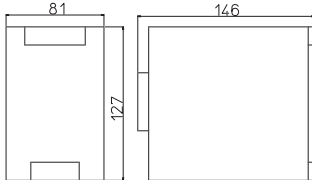

PIN assignment

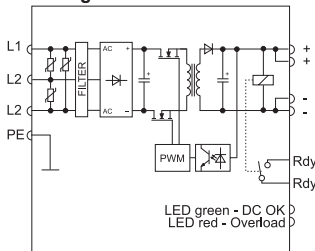

Parallel/redundant mode

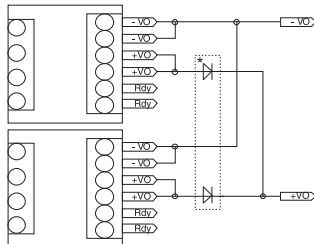

* Redundant Module 722999

Description	Part-No.	Type	PU	
Screw terminal				
Output voltage/current	DC 24 V/ 30 A	722802	CPSB3-720-24	1
	DC 48 V/ 15 A	722807	CPSB3-720-48	1

Input	CPSB3-720-24	CPSB3-720-48
Nominal voltage	3× AC 400–500 V	
Operation voltage range	3× AC 340–550 V	
Line frequency	47 – 63 Hz	
Rated current	U _i = AC 400 V: 1.9 A / U _i = AC 500 V: 1.7 A	
Inrush current	<50 A	
Internal fuse	–	
External fuse	Automatic: 3 × B 16 A, C 10 A (required)	
Power Factor Correction P.F.C.	>0.65	

Output	CPSB3-720-24	CPSB3-720-48
Rated voltage output	DC 24 V	DC 48 V
Rated current output	30 A	15 A
Max. output current	32 A	16.5 A
Short-circuit current	45 A (>80 A Hiccup)	22.5 A (>45 A Hiccup)
Voltage trim range	24/28 V	45/55 V
Accuracy	–	
Line regulation	–	
Load regulation	<1 %	
Rise time	–	
Temperature coefficient	–	
Ripple & Noise	<150 mV pp	<100 mV pp
Hold up time	>15 ms (AC 400 V)	
Status indication DC ON LED green	≥21.6 V	≥43.2 V
Status indication DC LOW LED red	≤21.6 V	≤43.2 V
Parallel/redundant operation	max. 2 devices / via external diodes	
Efficiency	>92 %	>94 %
Low power loss	<63 W	<46 W
Rated over load protection	> 90°C, auto-reset	
Over voltage protection	<33 V	<60 V
Short circuit characteristics	Hiccup-mode / Constant current	

General	
Switching frequency	approx. 70 – 110 kHz
Insulation voltage input/output	AC 3.0 kV _{eff}
Insulation voltage input / ground	AC 2.0 kV _{eff}
Insulation voltage output / ground	AC 1.0 kV _{eff}
Insulation resistance at DC 500 V	– MΩ
Operation temperature range	–20 °C – 60 °C
Derating	–
Storage temperature range	–25 °C – 85 °C
M.T.B.F.	>500000 h to SN29500 / >150000 h to MIL standard HDBK 217F
Relative humidity	20–90% RH, non-condensing
Dimensions (w × h × d) in mm	81.0 × 127.0 × 146.0
Cooling	Natural air cooling, forced cooling >50°C, 50 mm distance above/below
Housing material	Aluminum
Shock resistance	30 g 6 ms, 20 g 11 ms, 3 shocks / direction, 18 shocks in total, IEC60068-2-27:2008
Vibration resistance	5 – 17.8 Hz: ±1.6 mm, 17.8 – 500 Hz: 2 g 2 hours / axes X,Y,Z, IEC 60068-2-6:2007
Field installation	rail TS 35 (EN 50022)
Application height	– m
Installation position	vertical
Protection class	IP 20 (IEC529, EN60529)
IP rating	I (SELV, PELV)
Overvoltage category	II
Pollution degree	2
Weight (kg/piece)	1.200
Termination	Screw terminal: 0.2–6.0 mm ² , max. 0.62 Nm
Approvals	UL, cUL: UL 508, IEC 950, EN 60950 CE: EN 61000-4-2/3/4/5/6/11, EN 61000-6-2, EN 601000-6-4, EN 50178, EN 61558, EN 50081-1, EN 50082-2, EN 55022 Class B

Monitoring	
DC ON Control (Rdy)	Normally open
Switching voltage	AC 300 V / DC 150 V
Switching current	AC/DC 1 A
Switching capacity	300 VA / 30 W
Insulation voltage	AC 500 V

Power supply · regulated, 960 W, 3-phase

Primary switchmode power supply, PFC, 3-phase
Input: Wide range input AC 340 - 550 V
Output: 24 V / 48 V / 72 V



Dimensions

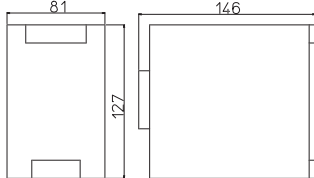

PIN assignment

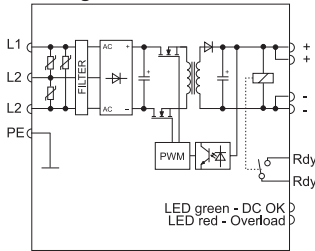

Derating

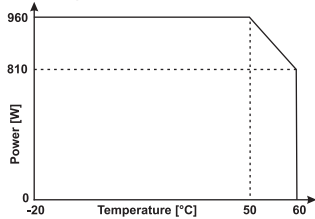

Redundant operation

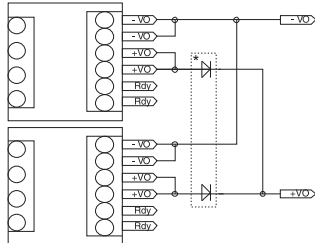

* Redundant Module 722999

Description	Part-No.	Type	PU	
Screw terminal				
Output voltage/current	DC 24 V / 40 A	722811	CPSB3-960-24	1
	DC 48 V / 20 A	722812	CPSB3-960-48	1
	DC 72 V / 13.3 A	722813	CPSB3-960-72	1
Input				
	CPSB3-960-24	CPSB3-960-48	CPSB3-960-72	
Nominal voltage		3× AC 400–500 V		
Operation voltage range		3× AC 340–550 V		
Line frequency		47 – 63 Hz		
Rated current	U _i = AC 400 V: 2.8 A / U _i = AC 500 V: 2.2 A			
Inrush current	<50 A			
Internal fuse	–			
External fuse	Automatic: 3 × B 16 A, C 10 A (required)			
Power Factor Correction P.F.C.	>0.7			
Output				
Rated voltage output	DC 24 V	DC 48 V	DC 72 V	
Rated current output	40 A	20 A	13.3 A	
Max. output current	44 A	21.5 A	14 A	
Short-circuit current	60 A (>90 A Hiccup)	30 A (>70 A Hiccup)	20 A (>30 A Hiccup)	
Voltage trim range	24/28 V	45/55 V	72/84 V	
Accuracy	–			
Line regulation	–			
Load regulation	<1 %			
Rise time	–			
Temperature coefficient	–			
Ripple & Noise	<100 mV		<300 mV	
Hold up time	>10 ms (AC 400 V); >15 ms (AC 500 V)			
Status indication DC ON LED green	≥21.6 V	≥43.2 V	≥64.8 V	
Status indication DC LOW LED red	≤21.6 V	≤43.2 V	≤64.8 V	
Parallel/redundant operation	max. 2 devices / via external diodes			
Efficiency	>91 %	>93 %	>94 %	
Low power loss	<95 W	<72 W	<62 W	
Rated over load protection	> 90°C, auto-reset			
Over voltage protection	<33 V	<60 V	<94 V	
Short circuit characteristics	Hiccup-mode / Constant current			
General				
Switching frequency	approx. 70 – 110 kHz			
Insulation voltage input/output	AC 3.0 kV _{eff}			
Insulation voltage input / ground	AC 2.0 kV _{eff}			
Insulation voltage output / ground	AC 1.0 kV _{eff}			
Insulation resistance at DC 500 V	– MΩ			
Operation temperature range	–20 °C – 60 °C (derating)			
Derating	>50 °C: -15 W / °C, UL 508: >45 °C: -15 W / °C			
Storage temperature range	–25 °C – 85 °C			
M.T.B.F.	>500000 h to SN29500 / >150000 h to MIL standard HDBK 217F			
Relative humidity	20–90% RH, non-condensing			
Dimensions (w × h × d) in mm	81.0 × 127.0 × 146.0			
Cooling	Natural air cooling, forced cooling >50°C, 50 mm distance above/below			
Housing material	Aluminum			
Shock resistance	30 g 6 ms, 20 g 11 ms, 3 shocks / direction, 18 shocks in total, IEC60068-2-27:2008			
Vibration resistance	5 – 17.8 Hz: ±1.6 mm, 17.8 – 500 Hz: 2 g 2 hours / axes X,Y,Z, IEC 60068-2-6:2007			
Field installation	rail TS 35 (EN 50022)			
Application height	– m			
Installation position	vertical			
Protection class	IP 20 (IEC529, EN60529)			
IP rating	I (SELV, PELV)			
Overvoltage category	II			
Pollution degree	2			
Weight (kg/piece)	1.200			
Termination	Screw terminal: 0.2–10.0 mm ² , max. 0.62 Nm		Screw terminal: 0.2–6.0 mm ² , max. 0.62 Nm	
Approvals				
	UL, cUL: UL 508, IEC 950, EN 60950			
	CE: EN 61000-4-2/3/4/5/6/11, EN 61000-6-2, EN 601000-6-4, EN 50178, EN 61558, EN 50081-1, EN 50082-2, EN 55022 Class B			
Monitoring				
DC ON Control (Rdy)	Normally open			
Switching voltage	AC 300 V / DC 150 V			
Switching current	AC/DC 1 A			
Switching capacity	300 VA / 30 W			
Insulation voltage	AC 500 V			

Power supply - Redundancy module

Redundant module 12 to 85 V, 50 A
Potential-free signalling contact
Status LED per input



Dimensions

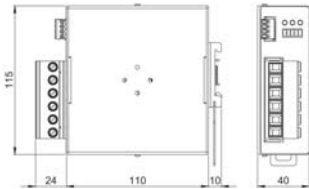

PIN assignment

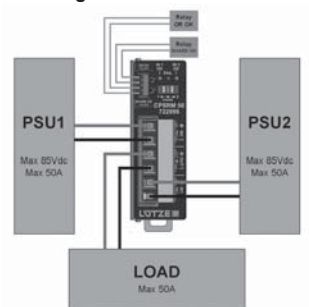

Use

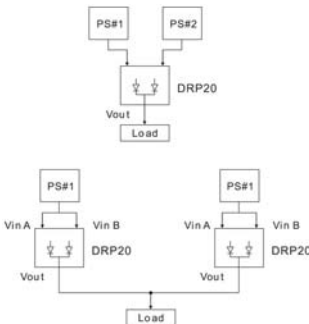

Description	Part-No.	Type	PU
Screw terminal			
Output voltage/current	DC 12 V–85 V/50 A	722999	CPSRM50
			1
Input			
CPSRM50			
Nominal voltage		–	
Operation voltage range		DC 12–85 V	
Inputs		2	
Rated current		max. 50 A per input	
Internal fuse		–	
External fuse		–	
Output			
Rated voltage output		–	
Rated current output		–	
Max. output current		300 A	
Voltage drop		<0.2 V	
Inverse voltage		–	
Low power loss		Max. 10 W	
No-load power		<1.5 W	
Status indication DC ON LED green		IN1, IN2 OK	
Status indication DC ON LED red		Redundancy error	
Overtemperature protection		No	
Over voltage protection		No	
General			
Operation temperature range		–20 °C – 50 °C	
Derating		–	
Storage temperature range		–25 °C – 85 °C	
M.T.B.F.		–	
Dimensions (w × h × d) in mm		40.0 × 115.0 × 110.0	
Cooling		Air convection	
Housing material		Aluminum	
Shock resistance		30 g 6 ms, 20 g 11 ms, 3 shocks / direction, 18 shocks in total, IEC60068-2-27:2008	
Vibration resistance		5 – 17.8 Hz: ±1.6 mm, 17.8 – 500 Hz: 2 g 2 hours / axes X,Y,Z, IEC 60068-2-6:2007	
Field installation		rail TS 35 (EN 50022)	
Application height		– m	
Installation position		vertical	
Protection class		IP 20 (IEC529, EN60529)	
Overvoltage category		II	
Pollution degree		2	
Weight (kg/piece)		0.200	
Termination		Input: pluggable screw connection: 0,2–16 mm ² Output: pluggable screw connection: 0,2–16 mm ² Relay: pluggable screw connection: 0,2–1,5 mm ²	
Approvals			
		UL, cUL: UL 508 listed, UL 60950-1 recognised CE: EN 55022 Class B, EN 55024 CE: EN 61000-4-2/3/4/6/8, EN 61204-3	
Monitoring			
DC ON Control (Rdy)		N/O contact	
Switching voltage		Ac 300 V/DC 24 V	
Switching current		AC/DC 1 A	
Switching capacity		300 VA / 30 W	
Insulation voltage		DC 100 V	

Power supply · regulated, 2400 W

Primary switchmode power supply, PFC, 3-phase

Input: Wide range input AC 340 - 550 V

Output: DC 24 V, 100 A / DC 48 V, 50 A



Range of functions

The new power compact series provides a number of additional adjustment options via function keys. The selected functions are shown on a display. In addition, the current output voltage and current are displayed for normal operation.

Input protection

- Active Surge suppressor and inrush limiter (ASSIL) as protection against overvoltages according to VDE 0160
- PFC error monitoring
- Phase monitoring with automatic reduction of the output power
- Automatic start/restart system for over- and undervoltages

Output protection

- Adjustable current limiting between $0.1 I_N$ and I_N
- Hiccup autoreset based on current limiting or maximum output voltage (150%)

Status display and signal

- In addition to an LED for "DC OK" and error displays, the devices have the following analog outputs 0–10 V and 4–20 mA as direct function of the load current
- Programmable relay contact with the functions
 - Output voltage/current,
 - Overload,
 - Overtemperature

Additional functions

- Temperature-compensated battery charging function
- Display and compensation of the voltage drop for long cables
- Remote On/Off of the output voltage
- DC 12 V auxiliary voltage
- Monitoring and control interface based on RS232 (optional)
- Integrated O-ring diode
- Load sharing in parallel operation
- Load current sharing

Description	Part-No.	Type	PU	
Screw terminal				
Output voltage/current	DC 24 V/100 A	722814	CPSB3-2400-24	1
	DC 48 V/50 A	722816	CPSB3-2400-48	1
Input				
	DC 24 V/100 A		DC 48 V/50 A	
Nominal voltage	3× AC 400–500 V			
Operation voltage range	AC 340 V–550 V/DC 520 V–750 V			
Line frequency	47 – 63 Hz			
Rated current	$U_i = AC 400 V: 4.5 A / U_i = AC 500 V: 3.5 A$			
Inrush current	<AC 10 A (active inrush current limitation)			
Internal fuse	–			
External fuse	Automatic: 3 × C 10 A (required)			
Power Factor Correction P.F.C.	>0.92			
Input protection	Surge protection according to VDE 0160, over/undervoltage (auto restart) Phase monitoring (reduced output power): PFC error			
Output				
Rated voltage output	DC 24 V		DC 48 V	
Rated current output	100 A		50 A	
Max. output current	>150 A, 5 s, with $U_{out} > 90\%$		>75 A, 5 s, with $U_{out} > 90\%$	
Short-circuit current	150 A, 5 s		75 A, 5 s	
Voltage trim range	DC 11.5–29 V		DC 23–56 V	
Load regulation	<1 %			
Rise time	< 4.5 S			
Temperature coefficient	–			
Ripple & Noise	<200 mV			
Hold up time	>10 ms (AC 400 V); >10 ms (AC 500 V)			
Status indication DC ON LED green	alphanumeric display			
Status indication DC LOW LED red	alphanumeric display			
Parallel/redundant operation	max. 4 devices			
Efficiency	>92 %			
Low power loss	<200 W			
Over voltage protection	>30 V			
Short circuit characteristics	adjustable: Hiccup, current limiting			
General				
Insulation voltage input/output	AC 3.0 kV _{eff}			
Insulation voltage input / ground	AC 1.5 kV _{eff}			
Insulation voltage output / ground	AC 0.5 kV _{eff}			
Operation temperature range	-20 °C – 60 °C (derating)			
Derating	>45 °C: -40 W/°C			
Storage temperature range	-25 °C – 85 °C			
M.T.B.F.	>500000 h to SN29500 / >150000 h to MIL standard HDBK 217F			
Dimensions (w × h × d) in mm	233.0 × 158.0 × 102.0			
Cooling	Natural air cooling, forced cooling >45 °C, 80 mm distance top/bottom, 10 mm side			
Housing material	Aluminium			
Shock resistance	30 g			
Vibration resistance	5 – 17,8 Hz: ±1,6 mm, 17,8 – 500 Hz: 2 g 2 Hours / Achsen X,Y,Z, IEC 60068-2-6:2007			
Field installation	rail TS 35 (EN 50022)			
Installation position	vertical			
Protection class	IP 20 (IEC529, EN60529)			
IP rating	I (SELV, PELV)			
Overvoltage category	II			
Pollution degree	2			
Weight (kg/piece)	2.800			
Termination	Screw connection: input 0.2–4.0 mm ² /output 0.2–35 mm ² /auxiliary 0.2–1.5 mm ²			
Approvals	Standards: UL 508, IEC 950, EN 60950, EN 55011 CE: EN 61000-4-5, Surge immunity level IV, VDE 0160 CE: EN 61000-4-2/3/4/5/6/11			
Monitoring				
DC ON Control (Rdy)	Relay, N/O contact active, adjustable, DCok: 90–110 % Uset, ACok: acc. input voltage range, overload Overtemperature range, charging complete			
Switching capacity	AC/DC 30 V, 1 A, 30 W			
Insulation voltage	AC 500 V			
Output current	galvanically isolated: 0–10 V and 4–20 mA			
Interface				
User Interface	LCD display 16 × 2 character, multi language, 4 keys (command and navigation)			
Auxiliary voltage output	galvanically isolated DC 12 V, 100 mA			
NTC	Temperature-controlled battery charging (mandatory)			

Power supply · regulated, 2400 W

Primary switchmode power supply, PFC, 3-phase
 Input: Wide range input AC 340 - 550 V
 Output: DC 24 V, 100 A / DC 48 V, 50 A

Dimensions

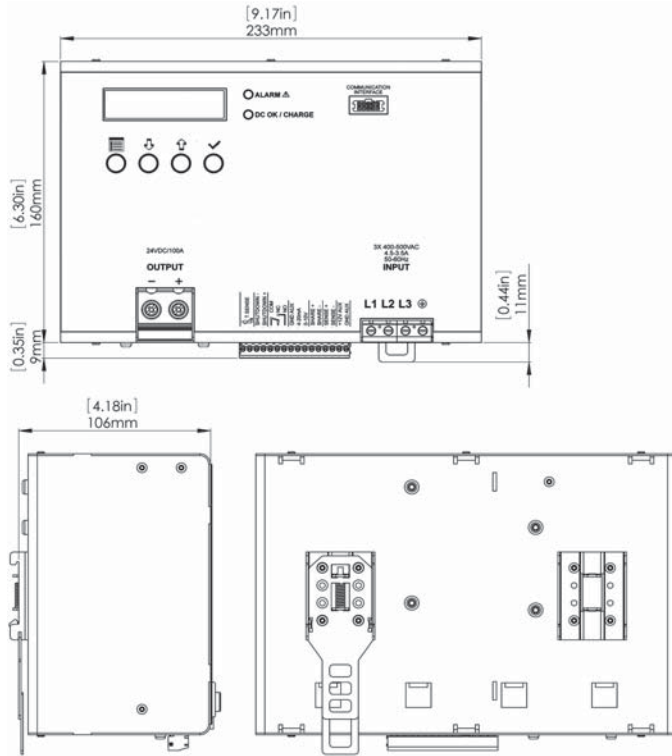

PIN assignment

- 1 Display
- 2 Control Keys
- 3 Output Connector
- 4 Auxiliary Connector
- 5 Input Connector
- 6 DIN Rail Fixing Clamp
- 7 Communication Interface
- 8 Status LEDs
- 9 Buzzer (Internal)

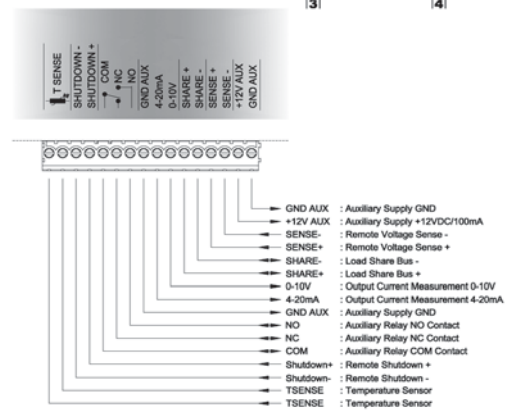
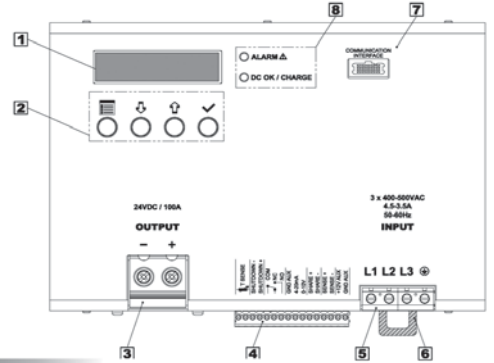

Serial operation

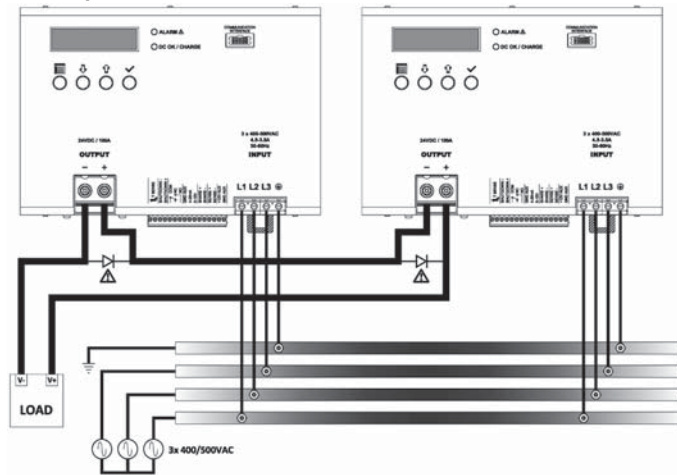

Parallel/redundant mode

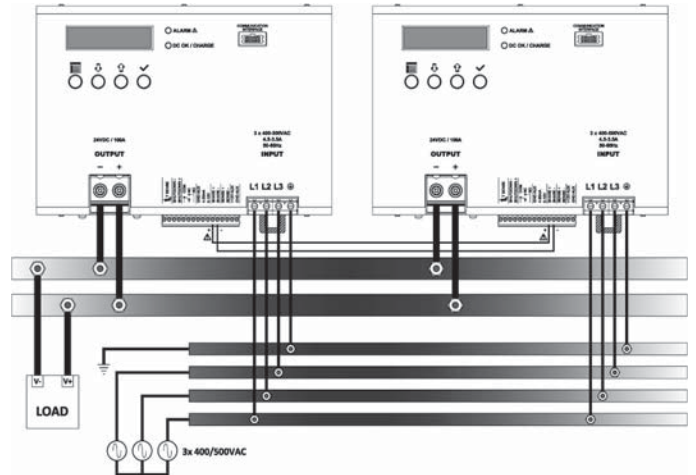

Charging operation

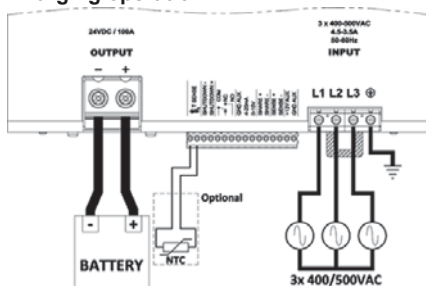

Output voltage in 0–10 V

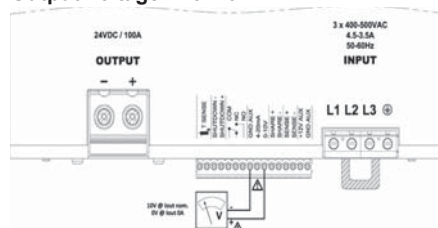

Output voltage in 4–20 mA

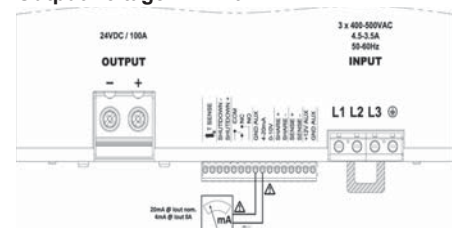

DC UPS Battery Management System - 240 W

Uninterrupted DC system voltage

DC UPS for lead batteries

Input: DC 24 V, Output: max. DC 10 A



Dimensions



Description	Part-No.	Type	PU
DC UPS 24 V	723110	CNUPS24	1
Note			
Comments	Suitable for power supply with settable output voltage Load mode with simultaneous charging Integrated battery fuse Deep discharging protection		
Input			
Input voltage	DC 26 - 28.5 V		
Input current	DC 3 – 20 mA		
Status Indication	LED green: PS Ok, LED red: Reverse polarity LED green: Batt. Ok, LED red: Batt. Low		
Configuration	via keys/LCD display or software Powermaster (free download Lütze web page)		
Low power loss	-		
Protection device Input	No		
Energy storage			
Memory type	chemical (lead based, Ni-MH / Ni-Cd, Li-ION / LiFePo ₄)		
Nominal battery voltage	DC 24 V		
max. charging current	DC 2 A or DC 4 A		
max. battery capacity	75%@26V, 85%@27V, 100%@28V		
Max. output current	10 A		
Switching time on memory medium	-		
Backup time	depends on battery and charging current		
Fuse for memory medium	Vehicle fuse 15 A / 42 V		
Deep discharge protection	18.5 V ±0.5 V		
Output			
Output voltage	DC 20 - 28 V		
Output current	DC 10 A max.		
Status Indication	LED yellow: Load Ok		
General			
Housing material	Aluminum		
Protection class	IP 20 acc. to EN 60529		
Dimensions (w × h × d) in mm	54.0 × 115.0 × 110.0		
Field installation	Mounting rail TS 35 acc. to IEC 60715		
Installation position	vertical, with 20 mm distance to other devices		
Termination	Connector with screws: 2.5 mm ² (AWG 24–12)		
Operation temperature range	-20 °C – 50 °C		
Storage temperature range	-20 °C – 85 °C		
Weight (kg/piece)	0.300		
Cooling	free convection		
Relative humidity	95% not condensing		
Overvoltage category	II		
Pollution degree	2 (IEC 664-1)		
Insulation voltage input / ground	0.5 kV @ 1 min		
Standards	UL 508, CE, EN 60950-1, EN 61000-6-2/4		
Monitoring			
Monitored function	Battery mode		
Number of channels	1		
Switching voltage	DC 24 V		
Switching current	DC 1 A		
Contact type	Change over contact		

DC UPS Battery Management System - 480 W

Uninterrupted DC system voltage

DC UPS for lead batteries, NiMH (NiCd), Li-ION (LiFePO₄)

Input: wide-range input DC 12 V, DC 24 V, output: max. DC 20 A

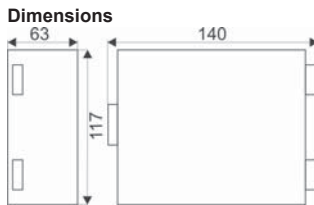

Description	Part-No.	Type	PU
DC UPS 12 V / 24 V	723100	CDCU20 12/24DC UPS	1
Note			
Comments	Monitoring via LCD display Suitable for DC12V and DC24V Suitable for lead batteries, Ni-MH, Li Digital control Battery charging current up to 5A Output current up to 20A Cold start automatic Configuration / monitoring also via software Remote On / Off		
Input			
Input voltage	DC 12 V or 24 V		
Input current	DC max. 20 A		
Status Indication	see monitoring		
Configuration	via keys/LCD display or software Powermaster (free download Lütze web page)		
Low power loss	<3 W		
Protection device Input	No		
Energy storage			
Memory type	chemical (lead based, Ni-MH / Ni-Cd, Li-ION / LiFePO ₄)		
Nominal battery voltage	DC 12 V or DC 24 V		
max. charging current	DC 5 A		
max. battery capacity	max. 150 Ah		
Max. output current	20 A, 35 A @ 5 sec.		
Switching time on memory medium	<5 µsec		
Backup time	Can be configured max. up to deep discharging protection		
Output			
Output voltage	DC 10 - 29 V		
Output current	DC 20 A, 35 A @ 5 sec		
Rated voltage output	-		
Status Indication	see monitoring		
General			
Housing material	Aluminum		
Protection class	IP 20		
Dimensions (w × h × d) in mm	63.0 × 117.0 × 140.0		
Field installation	Mounting rail TS 35 acc. to IEC 60715		
Installation position	vertical		
Termination	IN/Battery/Out : 6 pin connector 2.5mm ² , Grid dimensions 5.08 Auxiliary: 7 pin connector 0.5mm ² , Grid dimensions 2.54 Temperature sensor: 2 pin, friction lock, Grid dimensions 2 mm USB: Mini USB connector		
Max. power loss (Nominal operations)	<13 W		
Max. power loss (Battery mode)	<18 W		
Charging efficiency	>90 %		
Operation temperature range	-20 °C – 60 °C		
Storage temperature range	-20 °C – 85 °C		
Weight (kg/piece)	0.500		
Cooling	free convection		
Relative humidity	95% not condensing		
Overvoltage category	II		
Pollution degree	2 (IEC 664-1)		
Insulation voltage input / ground	0.5 kV @ 1 min		
Standards	UL 508, CE, EN 55011		
User Interface			
USB	Connection to PC		
Control Elements	4 keys (menu selection and programming)		
Status indication	LED red ON: System error, flashing: Battery mode		
LCD display	1.5 inch, colour, graphic		
Monitoring			
Monitored function	Coulomb counter, battery temperature, battery operating hours, no. of charging cycles		
Number of channels	2 (Function can be configured)		
Switching voltage	30 V		
Switching current	2 A		
Contact type	make contact		

DC UPS Battery Management System · Maintenance-free buffer module

Uninterrupted DC system voltage

Capacitive energy store

Input: wide-range input DC 12 V - DC 85 V, output: max. DC 20 A



Dimensions

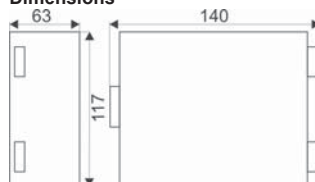

Description	Part-No.	Type	PU
Capacitive energy store	723120	CBU150U	1
Note			
Comments	Input voltage range DC 12 V to DC 85 V Automatic detection of DC supply Inexpensive design thanks to standard electrolyte capacitors Digital control Compact size		
Input			
Input voltage	DC 12 V / 24 V / 48 V / 72 V or automatic recognition		
Input current	DC max. 20 A		
Status Indication	LED green: selected voltage		
Configuration	Key: selection of input voltage		
Energy storage			
Memory type	capacitive		
Discharge time at I _{max}	12 V: 600 ms, 24 V: 300ms, 48 V: 150 ms, 72 V: 75 ms		
Output			
Output voltage	Input voltage: -1 V		
Output current	max. 20 A		
Ripple	<250 mV @ DC 24 V, 20 A		
Short circuit characteristics	enabled		
Protection device output	Over voltage protection, active		
Status Indication	green LED: DC OK, red LED : Overload		
General			
Housing material	Aluminum		
Protection class	IP 20		
Dimensions (w × h × d) in mm	63.0 × 140.0 × 117.0		
Field installation	Mounting rail TS 35 acc. to IEC 60715		
Installation position	vertical, with 20 mm distance to other devices		
Termination	Plug-in screw terminal 2.5mm ² (AWG24-12)		
Operation temperature range	-20 °C – 70 °C		
Storage temperature range	-20 °C – 85 °C		
Weight (kg/piece)	0.800		
Cooling	free convection		
Relative humidity	95% not condensing		
Insulation voltage input / ground	0.75 kV		
Standards	UL 508, CE, EN 55011		
Monitoring			
Number of channels	2 (Backup, RdyOn)		
Switching voltage	DC 12 V		
Switching current	DC 1 A		
Contact type	make contact		

DC UPS Battery Management System · Lead acid battery housing

Battery housing for holding two lead batteries 12 V / 1.2 Ah

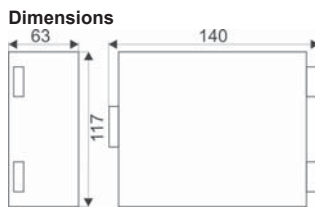

Description	Part-No.	Type	PU
Battery housing without battery	723115	CNBP30	1
Note			
Comments	Suitable for DC12V and DC24V applications Integrated self-healing fuse		
Energiespeicher			
Memory type	2× lead batteries DC 12 V / 1.2 Ah		
Batteriemasse max. (B×H×T) in mm	-		
max. charging current	600 mA @ DC 12 V, 300 mA @ DC 24 V		
max. battery capacity	-		
Max. output current	5 A @ DC 12 V, 3 A @ DC 24 V		
Switching time on memory medium	-		
Backup time	-		
Fuse for memory medium	15 A, automatic resetting		
Deep discharge protection	-		
General			
Housing material	Aluminum		
Protection class	IP 20 acc. to EN 60529		
Dimensions (w × h × d) in mm	54.0 × 115.0 × 110.0		
Field installation	Mounting rail TS 35 acc. to IEC 60715		
Installation position	vertical, with 20 mm distance to other devices		
Termination	Connector with screws: 2.5 mm ² (AWG 24–12)		
Operation temperature range	-20 °C – 40 °C		
Storage temperature range	-20 °C – 40 °C		
Configured weight (kg/unit) max.	1.2		
Cooling	free convection		
Relative humidity	95% not condensing		
Insulation voltage input / ground	0.5 kV @ 1 min		
Overvoltage category	II		
Pollution degree	2 (IEC 664-1)		
Standards	-		

Modular, flexible and safe: LOC

The intelligent LÜTZE Overload

Adjustable rated current
(1 A...10 A in 1 A Steps)

Adjustable characteristic
(fast- ... slow acting)

“Power-ON”-effect
to switch on capacitive loads

Single or centralized fault indication

Last status memorization

Spring terminals

Small device – width 8,1 mm

Response time independent
of temperature

Contact slots for each potential usable
for jumper combs

Solid state relay with current control
switching frequency up to 1 kHz

Contact slots for each potential usable for
jumper combs



C-Box / LOCC-Box-Net Current Control System

*Sky***BLUE**

Remote ON / OFF

Manual ON / OFF

Status indication “operation”, “fault”,
“90 % load” and “100 % load”

Adjustment cover accommodates
lock out tags

Flammability class
UL-94-V0; NFF I2,F2

Power distribution via direct
supply or supply set

Optional remote Gateway interface

UL 508 Listed

The picture shows 5 x LOCC-Box incl. supply set

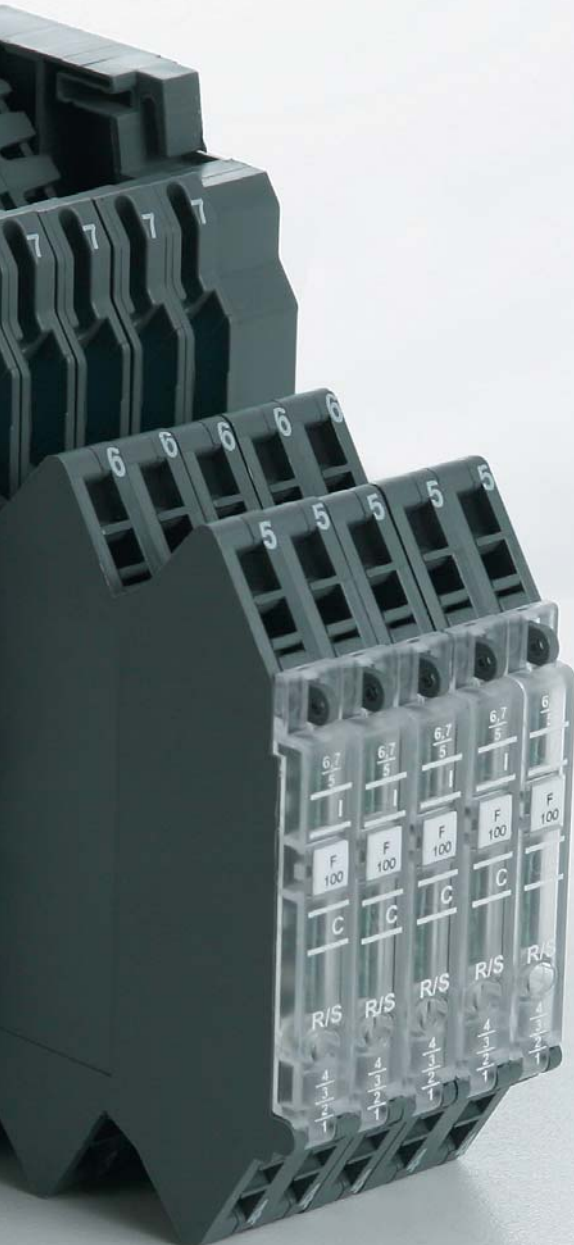

Intelligent current monitoring management system: LCOS-C

Flammability class
UL 94-V0

Bus coupler for all
conventional systems

Adjustable characteristics

Adjustable rated current

Manual On /Off

2-channel design

2-pole disconnection

"Power ON" effect

Saving of the last status

**Temperature-independent
response time**

Supply - also with
galvanic insulation

Clear labelling



and energy C



SkyBLUE

Intermediate in-feed option

Status output operation
failure, manual switch-off, 90 % capacity

Remote On/Off

**Modular expandable
data bus**

**Modular expandable
power bus**

**Integrated protection
against alignment**

**UL508,
GL approvals**

**Plug-in functional
assemblies**

Load monitoring · Microcompact LOCC-Box

Electronic load monitoring up to DC 10 A
 Single-channel design, Adjustable current range: DC 1 A – 10 A
 Adjustable characteristics, fast, medium-speed, slow 1, -2, -3



Dimensions

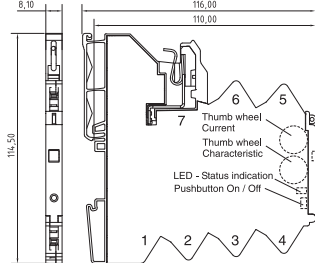

PIN assignment

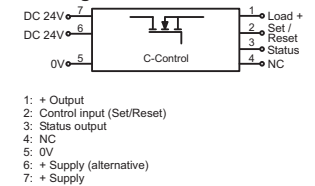

Signal output

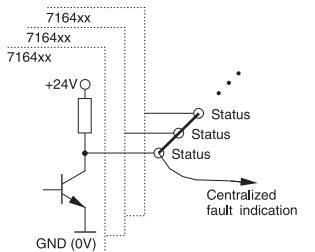
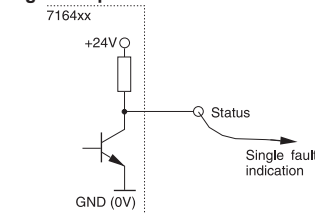

Description	Part-No.	Type	PU	
Spring terminal				
Nominal voltage	DC 12 / 24 V	716400	LOCC-Box-FB 7-6400	1
	DC 12 / 24 V	716401	LOCC-Box-FB 7-6401	1
	DC 12 / 24 V	716401.0050	LOCC-Box-FB 7-6401	50

Input	LOCC-Box-FB 7-6400	LOCC-Box-FB 7-6401
Nominal voltage	DC 12 / 24 V	
Operation voltage range	DC 10 V – 30 V	
Rated current	DC 10 A	
Supply current	DC 40 A over Cu-rails 10 × 3 mm	
Reverse voltage protection	internal electronics	
Termination	screwless disconnect slide	
Control input (Set / Reset)		
Signal level	DC 12 / 24 V (EN 61131)	
OFF	Pulse with falling edge >100 ms, <800 ms	
ON	Pulse with falling edge > 1 s	
Output		
Switching element	MosFet	
Output current	max. DC 10 A	
Voltage drop	<170 mV (10 A)	
Status Indication	LED green: Operating voltage present, no error LED red: Error in load circuit	
Switch-on capacity	10000 µF	
Current range	1 A – 10 A (adjustable via switch in 1 A steps)	
Characteristic	fast-acting (1), medium (2), slow 1 (3), slow 2 (4), slow 3 (5) see 'characteristic curves'	

Signal output	DC 12/24 V: operating voltage on standby, no error, DC 0 V: error, output switched off	DC 12/24 V: operating voltage on standby, no error, DC 0 V: error, output switched off and manual "OFF"
Signal level		

Switching element	Transistor, collector with pull-up resistance	
General		
Housing material	PA 6.6 (UL 94-V0; NFF I2, F2)	
Field installation	rail TS 35 (EN 60175)	
Protection class	IP 20	
Installation position	Optional	
Termination	Spring terminal 0.25–2.5 mm ²	
Operation temperature range	-25 °C – 50 °C	
Storage temperature range	-40 – 85 °C	
Dimensions (w × h × d) in mm	8.1 × 114.5 × 116.0	
Weight (kg/piece)	0.120	
Approvals	cULus, GL in preparation	
Standards	EN 60950-1; EN 61131-1,2; EN 61000; EN 60947-4-1; EN 55022	

Accessories	Color	Article number	Type	PU
0 V collective terminal		716420	LOCC Box-SK 7-6420	2
Supply terminal with cutout for copper rail to increase current		716421	LOCC Box-EKL 7-6421	2
Distance terminal without contact		716422	LOCC Box-DKL 7-6422	2
LOCC Box empty housing without terminal		716424	LOCC Box-DY 7-6424	2
Supply kit (supply and end terminals) 10 mm ²		716425	LOCC Box ES 7-6425	1
Supply kit (supply and end terminals) 16 mm ²		716447	LOCC Box ES 7-6477	1
Jumper comb, 8-pin, 6 A	white	716428	LOCC Box BKW 7-6428	5
Jumper comb, 8-pin, 6 A	red	716429	LOCC Box BKR 7-6429	5
Jumper comb, 8-pin, 6 A	blue	716430	LOCC Box BKB 7-6430	5
Jumper comb, 16-pin, 6 A	white	716438	LOCC Box BKW 7-6438	5
Jumper comb, 16-pin, 6 A	red	716439	LOCC Box BKB 7-6440	5
Jumper comb, 16-pin, 6 A	blue	716440	LOCC Box BKR 7-6439	5
Tag holder (quantity 200)	white (5×5 mm)	716431	LOCC Box BWZ 7-6431	1
Tag holder (quantity 200)	red (5×5 mm)	716432	LOCC Box BZR 7-6432	1
Tag holder (quantity 200)	blue (5×5 mm)	716433	LOCC Box BZB 7-6433	1
Tag holder (quantity 200)	yellow (5×5 mm)	716434	LOCC Box BZG 7-6434	1
Tag holder (quantity 120)	white (12×6 mm)	716441	LOCC Box BWZ 7-6441	1
Tag holder	white (39.3×5 mm)	716443	LOCC Box BWZ 7-6443	20
Cover for tag holder 716443	transparent	716444	LOCC Box-BAD 7-6444	20
A4 label sheets (quantity 240)	white	716445	LOCC Box-LEB 7-6445	10
Tag holder (quantity 50), printing 1–50	white	716446	LOCC Box BWZ 7-6446	1
Copper rail, 1 m		716426	LOCC Box CU 7-6426	1
CU rail cover, 1 m		716427	LOCC Box AD 7-6427	1

Load monitoring · Microcompact LOCC-Box

Electronic load monitoring up to DC 2 A

Single-channel design, Adjustable current range: DC 0.2 A – 2 A

Adjustable characteristics, fast, medium-speed, slow



Dimensions

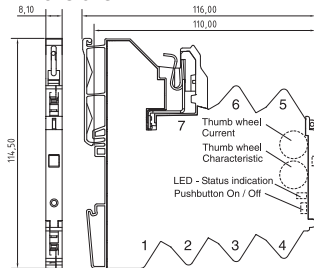

PIN assignment

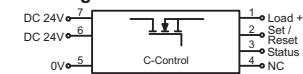

- 1: + Output
- 2: Control input (Set/Reset)
- 3: Status output
- 4: NC
- 5: 0V
- 6: + Supply (alternative)
- 7: + Supply

Signal output

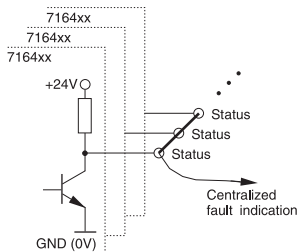
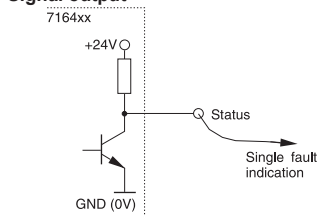

Description	Part-No.	Type	PU	
Spring terminal				
Nominal voltage	DC 12 / 24 V	716409	LOCC-Box-FB2A 7-6409	1
Input				
LOCC-Box-FB2A 7-6409				
Nominal voltage	DC 12 / 24 V			
Operation voltage range	DC 10 V – 32 V			
Rated current	DC 2 A			
Supply current	DC 40 A over Cu-rails 10 × 3 mm			
Reverse voltage protection	internal electronics			
Termination	screwless disconnect slide			
Control input (Set / Reset)				
Signal level	DC 12 / 24 V (EN 61131)			
OFF	Pulse with falling edge >100 ms, <800 ms			
ON	Pulse with falling edge > 1 s			
Output				
Switching element	MosFet			
Output current	max. DC 2 A			
Voltage drop	<140 mV (2 A)			
Status Indication	LED green: Operating voltage present, no error LED red: Error in load circuit			
Switch-on capacity	10000 µF			
Current range	0.2 A – 2 A (adjustable via switch in 0.2 A steps)			
Characteristic	fast (1), medium (2), slow 1 (3) see 'Characteristic curves'			
Current limitation	13.75 A			
Signal output				
Signal level	DC 12/24 V: operating voltage on standby, no error, DC 0 V: error, output switched off and manual "OFF"			
Switching element	Transistor, collector with pull-up resistance			
General				
Housing material	PA 6.6 (UL 94-V0; NFF I2, F2)			
Field installation	rail TS 35 (EN 60175)			
Protection class	IP 20			
Installation position	Optional			
Termination	Spring terminal 0.25–2.5 mm ²			
Operation temperature range	-25 °C – 50 °C			
Storage temperature range	-40 – 75 °C			
Dimensions (w × h × d) in mm	8.1 × 114.5 × 116.0			
Weight (kg/piece)	0.120			
Approvals	cULus, GL in preparation			
Standards	EN 60950-1; EN 61131-1,2; EN 61000; EN 60947-4-1; EN 55022			
Accessories				
0 V collective terminal	Color	Article number	Type	PU
Supply terminal with cutout for copper rail to increase current		716420	LOCC Box-SK 7-6420	2
Distance terminal without contact		716421	LOCC Box-EKL 7-6421	2
LOCC Box empty housing without terminal		716422	LOCC Box-DKL 7-6422	2
Supply kit (supply and end terminals) 10 mm ²		716424	LOCC Box-DY 7-6424	2
Supply kit (supply and end terminals) 16 mm ²		716425	LOCC Box ES 7-6425	1
Supply kit (supply and end terminals) 16 mm ²		716447	LOCC Box ES 7-6477	1
Jumper comb, 8-pin, 6 A	white	716428	LOCC Box BKW 7-6428	5
Jumper comb, 8-pin, 6 A	red	716429	LOCC Box BKR 7-6429	5
Jumper comb, 8-pin, 6 A	blue	716430	LOCC Box BKB 7-6430	5
Jumper comb, 16-pin, 6 A	white	716438	LOCC Box BKW 7-6438	5
Jumper comb, 16-pin, 6 A	red	716439	LOCC Box BKB 7-6440	5
Jumper comb, 16-pin, 6 A	blue	716440	LOCC Box BKR 7-6439	5
Tag holder (quantity 200)	white (5×5 mm)	716431	LOCC Box BZW 7-6431	1
Tag holder (quantity 200)	red (5×5 mm)	716432	LOCC Box BZR 7-6432	1
Tag holder (quantity 200)	blue (5×5 mm)	716433	LOCC Box BZB 7-6433	1
Tag holder (quantity 200)	yellow (5×5 mm)	716434	LOCC Box BKR 7-6434	1
Tag holder (quantity 120)	white (12×6 mm)	716441	LOCC Box BZW 7-6441	1
Tag holder	white (39.3×5 mm)	716443	LOCC Box BZW 7-6443	20
Cover for tag holder 716443	transparent	716444	LOCC Box-BAD 7-6444	20
A4 label sheets (quantity 240)	white	716445	LOCC Box-LEB 7-6445	10
Tag holder (quantity 50), printing 1–50	white	716446	LOCC Box BZW 7-6446	1
Copper rail, 1 m		716426	LOCC Box CU 7-6426	1
CU rail cover, 1 m		716427	LOCC Box AD 7-6427	1

Load monitoring · Microcompact LOCC-Box

Electronic load monitoring up DC 48 V to 6 A
 Single-channel design, Adjustable current range: DC 1 A – 6 A
 Adjustable characteristics, fast, medium-speed, slow 1, -2, -3



Dimensions

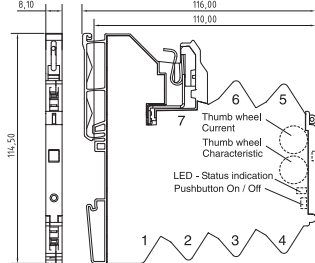

PIN assignment

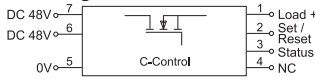

- 1: + Output
- 2: Control input (Set/Reset)
- 3: Status output
- 4: not used
- 5: 0V
- 6: + Supply (alternative)
- 7: + Supply

Signal output

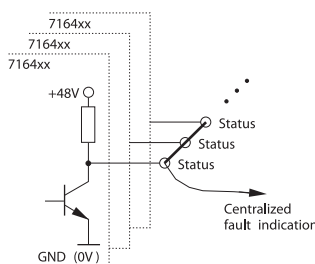
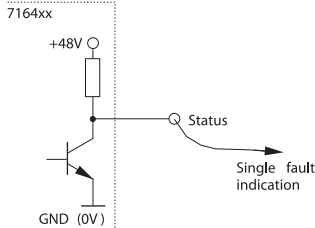

Description	Part-No.	Type	PU	
Spring terminal				
Nominal voltage	DC 48 V	716406	LOCC-Box-FB48 7-6406	1
Input				
LOCC-Box-FB48 7-6406				
Nominal voltage	DC 48 V			
Operation voltage range	DC 39 V – 58 V			
Rated current	DC 6 A			
Supply current	DC 40 A over Cu-rails 10 × 3 mm			
Reverse voltage protection	internal electronics			
Termination	screwless disconnect slide			
Control input (Set / Reset)				
Signal level	DC 48 V (EN 61131)			
OFF	Pulse with falling edge >100 ms, <800 ms			
ON	Pulse with falling edge > 1 s			
Output				
Switching element	MosFet			
Output current	max. DC 6 A			
Voltage drop	<85 mV (6 A)			
Status Indication	LED green: Operating voltage present, no error LED red: Error in load circuit			
Switch-on capacity	1000 µF			
Current range	1 A – 6 A (adjustable via switch in 1 A steps)			
Characteristic	fast-acting (1), medium (2), slow 1 (3), slow 2 (4), slow 3 (5) see 'characteristic curves'			
Current limitation	13.75 A			
Signal output				
Signal level	DC 48 V: operating voltage on standby, no error, DC 0 V: error, output switched off and manual "OFF"			
Switching element	Transistor, collector with pull-up resistance			
General				
Housing material	PA 6.6 (UL 94-V0; NFF I2, F2)			
Field installation	rail TS 35 (EN 60175)			
Protection class	IP 20			
Installation position	Optional			
Termination	Spring terminal 0.25–2.5 mm ²			
Operation temperature range	-25 °C – 50 °C			
Storage temperature range	-40 – 75 °C			
Dimensions (w × h × d) in mm	8.1 × 114.5 × 116.0			
Weight (kg/piece)	0.120			
Approvals	cULus in progress, GL in progress			
Standards	EN 60950-1; EN 61131-1,2; EN 61000; EN 60947-4-1; EN 55022			
Accessories				
0 V collective terminal	Color	Article number	Type	PU
Supply terminal with cutout for copper rail to increase current		716420	LOCC Box-SK 7-6420	2
Distance terminal without contact		716421	LOCC Box-EKL 7-6421	2
LOCC Box empty housing without terminal		716422	LOCC Box-DKL 7-6422	2
LOCC Box empty housing without terminal		716424	LOCC Box-DY 7-6424	2
Supply kit (supply and end terminals) 10 mm ²		716425	LOCC Box ES 7-6425	1
Supply kit (supply and end terminals) 16 mm ²		716447	LOCC Box ES 7-6477	1
Jumper comb, 8-pin, 6 A	white	716428	LOCC Box BKW 7-6428	5
Jumper comb, 8-pin, 6 A	red	716429	LOCC Box BKR 7-6429	5
Jumper comb, 8-pin, 6 A	blue	716430	LOCC Box BKB 7-6430	5
Jumper comb, 16-pin, 6 A	white	716438	LOCC Box BKW 7-6438	5
Jumper comb, 16-pin, 6 A	red	716439	LOCC Box BKR 7-6439	5
Jumper comb, 16-pin, 6 A	blue	716440	LOCC Box BKB 7-6440	5
Tag holder (quantity 200)	white (5×5 mm)	716431	LOCC Box BZW 7-6431	1
Tag holder (quantity 200)	red (5×5 mm)	716432	LOCC Box BZR 7-6432	1
Tag holder (quantity 200)	blue (5×5 mm)	716433	LOCC Box BZB 7-6433	1
Tag holder (quantity 200)	yellow (5×5 mm)	716434	LOCC Box BZG 7-6434	1
Tag holder (quantity 120)	white (12×6 mm)	716441	LOCC Box BZW 7-6441	1
Tag holder	white (39.3×5 mm)	716443	LOCC Box BZW 7-6443	20
Cover for tag holder 716443	transparent	716444	LOCC Box-BAD 7-6444	20
A4 label sheets (quantity 240)	white	716445	LOCC Box-LEB 7-6445	10
Tag holder (quantity 50), printing 1–50	white	716446	LOCC Box BZW 7-6446	1
Copper rail, 1 m		716426	LOCC Box CU 7-6426	1
CU rail cover, 1 m		716427	LOCC Box AD 7-6427	1

Load monitoring · Microcompact LOCC-Box-EC

Electronic load monitoring up to DC 10 A

Single channel version, fixed current range: DC 1 A - 10 A (see order code)

Fixed characteristic: fast-acting, medium-slow, slow 1, -2, -3 (see order code)



Dimensions

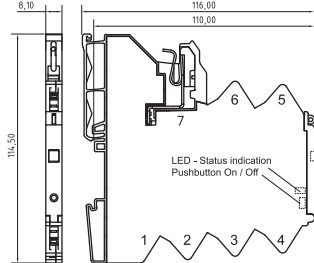

PIN assignment

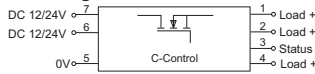

- 1: + Output
- 2: + Output
- 3: Status output
- 4: + Output
- 5: 0V
- 6: + Supply (alternative)
- 7: + Supply

Signal output

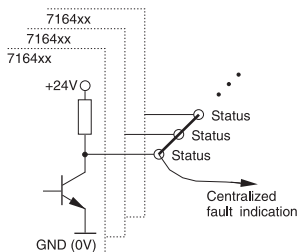
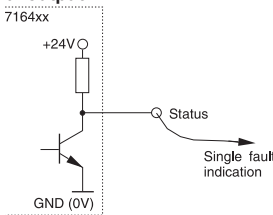

Order code

716407. 2 3 50		PU
Type		00 1 pc.
		50 50 pcs.
Current range	Characteristic	
1 1A	1 fast	
2 2A	2 medium	
3 3A	3 slow-1	
⋮	4 slow-2	
0 10A	5 slow-3	

Description	Part-No.	Type	PU	
Spring terminal				
Nominal voltage	DC 12 / 24 V	716407.xxxx	LOCC-Box-EC-I-C	
1				
Input				
LOCC-Box-EC-I-C				
Nominal voltage	DC 12 / 24 V			
Operation voltage range	DC 10 V – 30 V			
Rated current	DC 10 A			
Supply current	DC 40 A over Cu-rails 10 × 3 mm			
Reverse voltage protection	internal electronics			
Termination	screwless disconnect slide			
Control input (Set / Reset)				
Signal level	-			
OFF	-			
ON	-			
Output				
Switching element	MosFet			
Output current	max. DC 10 A			
Voltage drop	<170 mV (10 A)			
Status Indication	LED green: Operating voltage present, no error LED red: Error in load circuit			
Switch-on capacity	10000 µF			
Current range	1 A – 10 A (see order code)			
Characteristic	fast acting (1), medium (2), slow 1 (3), slow 2 (4), slow 3 (5) (see order code), see 'Characteristic curves'			
Signal output				
Signal level	DC 12/24 V: operating voltage on standby, no error, DC 0 V: error, output switched off and manual "OFF"			
Switching element	Transistor, collector with pull-up resistance			
General				
Housing material	PA 6.6 (UL 94-V0; NFF I2, F2)			
Field installation	rail TS 35 (EN 60175)			
Protection class	IP 20			
Installation position	Optional			
Termination	Spring terminal 0.25–2.5 mm ²			
Operation temperature range	-25 °C – 50 °C			
Storage temperature range	-40 – 85 °C			
Dimensions (w × h × d) in mm	8.1 × 114.5 × 116.0			
Weight (kg/piece)	0.120			
Approvals	cULus, GL in preparation			
Standards	EN 60950-1; EN 61131-1.2; EN 61000; EN 60947-4-1; EN 55022			
Accessories				
Color	Article number	Type	PU	
0 V collective terminal	716420	LOCC Box-SK 7-6420	2	
Supply terminal with cutout for copper rail to increase current	716421	LOCC Box-EKL 7-6421	2	
Distance terminal without contact	716422	LOCC Box-DKL 7-6422	2	
LOCC Box empty housing without terminal	716424	LOCC Box-DY 7-6424	2	
Supply kit (supply and end terminals) 10 mm ²	716425	LOCC Box ES 7-6425	1	
Supply kit (supply and end terminals) 16 mm ²	716447	LOCC Box ES 7-6477	1	
Jumper comb, 8-pin, 6 A	white	716428	LOCC Box BKW 7-6428	5
Jumper comb, 8-pin, 6 A	red	716429	LOCC Box BKR 7-6429	5
Jumper comb, 8-pin, 6 A	blue	716430	LOCC Box BKB 7-6430	5
Jumper comb, 16-pin, 6 A	white	716438	LOCC Box BKW 7-6438	5
Jumper comb, 16-pin, 6 A	red	716439	LOCC Box BKB 7-6440	5
Jumper comb, 16-pin, 6 A	blue	716440	LOCC Box BKR 7-6439	5
Tag holder (quantity 200)	white (5×5 mm)	716431	LOCC Box BZW 7-6431	1
Tag holder (quantity 200)	red (5×5 mm)	716432	LOCC Box BZR 7-6432	1
Tag holder (quantity 200)	blue (5×5 mm)	716433	LOCC Box BZB 7-6433	1
Tag holder (quantity 200)	yellow (5×5 mm)	716434	LOCC Box BZG 7-6434	1
Tag holder (quantity 120)	white (12×6 mm)	716441	LOCC Box BZW 7-6441	1
Tag holder	white (39.3×5 mm)	716443	LOCC Box BZW 7-6443	20
Cover for tag holder 716443	transparent	716444	LOCC Box-BAD 7-6444	20
A4 label sheets (quantity 240)	white	716445	LOCC Box-LEB 7-6445	10
Tag holder (quantity 50), printing 1–50	white	716446	LOCC Box BZW 7-6446	1
Copper rail, 1 m		716426	LOCC Box CU 7-6426	1
CU rail cover, 1 m		716427	LOCC Box AD 7-6427	1

Load monitoring · Microcompact LOCC-Box-EC

Electronic load monitoring up to DC 10 A

Single-channel design, Adjustable current range: DC 1 A – 10 A

Fixed characteristic: fast-acting, medium-slow, slow 1, -2, -3 (see order code)



Dimensions

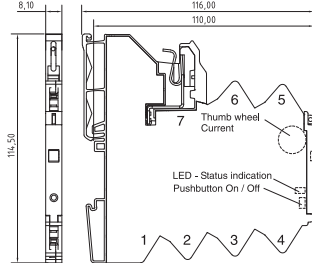

PIN assignment

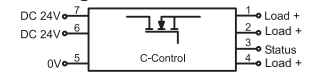

- 1: Load +
- 2: Load +
- 3: Status output
- 4: Load +
- 5: 0V
- 6: + Supply (alternative)
- 7: + Supply

Signal output

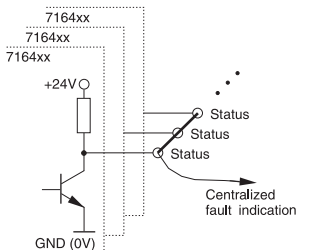
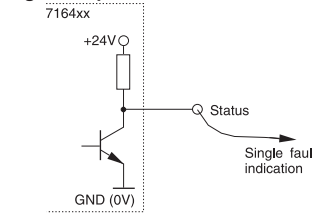

Order code

716412.03.50	
Type	PU
	00 1 pc.
	50 50 pcs.
Characteristic	
01	fast
02	medium
03	slow-1
04	slow-2
05	slow-3

Description	Part-No.	Type	PU
Spring terminal			
Nominal voltage	DC 12 / 24 V	716412.xxxx	LOCC-Box-EC-I-C
			1
Input			
LOCC-Box-EC-I-C			
Nominal voltage	DC 12 / 24 V		
Operation voltage range	DC 10 V – 30 V		
Rated current	DC 10 A		
Supply current	DC 40 A over Cu-rails 10 × 3 mm		
Reverse voltage protection	internal electronics		
Termination	screwless disconnect slide		
Control input (Set / Reset)			
Signal level	–		
OFF	–		
ON	–		
Output			
Switching element	MosFet		
Output current	max. DC 10 A		
Voltage drop	<170 mV (10 A)		
Status Indication	LED green: Operating voltage present, no error LED red: Error in load circuit		
Switch-on capacity	10000 µF		
Current range	1 A – 10 A (adjustable via switch in 1 A steps)		
Characteristic	fast acting (1), medium (2), slow 1 (3), slow 2 (4), slow 3 (5) (see order code), see 'Characteristic curves'		
Signal output			
Signal level	DC 12/24 V: operating voltage on standby, no error, DC 0 V: error, output switched off and manual "OFF"		
Switching element	Transistor, collector with pull-up resistance		
General			
Housing material	PA 6.6 (UL 94-V0; NFF I2, F2)		
Field installation	rail TS 35 (EN 60715)		
Protection class	IP 20		
Installation position	Optional		
Termination	Spring terminal 0.25–2.5 mm ²		
Operation temperature range	–25 °C – 50 °C		
Storage temperature range	–40 – 85 °C		
Dimensions (w × h × d) in mm	8.1 × 114.5 × 116.0		
Weight (kg/piece)	0.120		
Approvals	cULus in progress, GL in progress		
Standards	EN 60950-1; EN 61131-1,2; EN 61000; EN 60947-4-1; EN 55022		
Accessories			
	Color	Article number	Type PU
0 V collective terminal		716420	LOCC Box-SK 7-6420 2
Supply terminal with cutout for copper rail to increase current		716421	LOCC Box-EKL 7-6421 2
Distance terminal without contact		716422	LOCC Box-DKL 7-6422 2
LOCC Box empty housing without terminal		716424	LOCC Box-DY 7-6424 2
Supply kit (supply and end terminals) 10 mm ²		716425	LOCC Box ES 7-6425 1
Supply kit (supply and end terminals) 16 mm ²		716447	LOCC Box ES 7-6477 1
Jumper comb, 8-pin, 6 A	white	716428	LOCC Box BKW 7-6428 5
Jumper comb, 8-pin, 6 A	red	716429	LOCC Box BKR 7-6429 5
Jumper comb, 8-pin, 6 A	blue	716430	LOCC Box BKB 7-6430 5
Jumper comb, 16-pin, 6 A	white	716438	LOCC Box BKW 7-6438 5
Jumper comb, 16-pin, 6 A	red	716439	LOCC Box BKB 7-6440 5
Jumper comb, 16-pin, 6 A	blue	716440	LOCC Box BKR 7-6439 5
Tag holder (quantity 200)	white (5×5 mm)	716431	LOCC Box BZW 7-6431 1
Tag holder (quantity 200)	red (5×5 mm)	716432	LOCC Box BZR 7-6432 1
Tag holder (quantity 200)	blue (5×5 mm)	716433	LOCC Box BZB 7-6433 1
Tag holder (quantity 200)	yellow (5×5 mm)	716434	LOCC Box BZG 7-6434 1
Tag holder (quantity 120)	white (12×6 mm)	716441	LOCC Box BZW 7-6441 1
Tag holder	white (39.3×5 mm)	716443	LOCC Box BZW 7-6443 20
Cover for tag holder 716443	transparent	716444	LOCC Box-BAD 7-6444 20
A4 label sheets (quantity 240)	white	716445	LOCC Box-LEB 7-6445 10
Tag holder (quantity 50), printing 1–50	white	716446	LOCC Box BZW 7-6446 1
Copper rail, 1 m		716426	LOCC Box CU 7-6426 1
CU rail cover, 1 m		716427	LOCC Box AD 7-6427 1

Load monitoring · Microcompact LOCC-Box-SC

Electronic load monitoring up to DC 5 A
 Single-channel design, Adjustable current range: DC 1 A – 5 A
 Adjustable characteristics, fast, medium-speed, slow 1



Dimensions

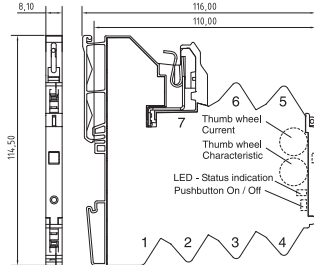

PIN assignment

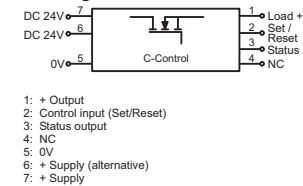

Signal output

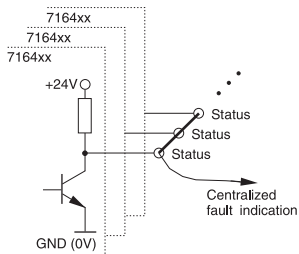
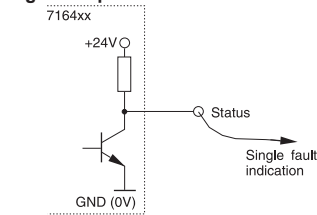

Description	Part-No.	Type	PU
Spring terminal			
Nominal voltage	DC 12 / 24 V	716408	LOCC-Box-SC 7-6408
			1
Input			
LOCC-Box-SC 7-6408			
Nominal voltage	DC 12 / 24 V		
Operation voltage range	DC 10 V – 30 V		
Rated current	DC 5 A		
Supply current	DC 40 A over Cu-rails 10 × 3 mm		
Reverse voltage protection	internal electronics		
Termination	screwless disconnect slide		
Control input (Set / Reset)			
Signal level	DC 12 / 24 V (EN 61131)		
OFF	Pulse with falling edge >100 ms, <800 ms		
ON	Pulse with falling edge > 1 s		
Output			
Switching element	MosFet		
Output current	max. DC 5 A		
Voltage drop	<85 mV (5 A)		
Status Indication	LED green: Operating voltage present, no error LED red: Error in load circuit		
Switch-on capacity	10000 µF		
Current range	1 A – 5 A (adjustable via switch in 1 A steps)		
Characteristic	fast (1), medium (2), slow 1 (3) see 'Characteristic curves'		
Signal output			
Signal level	DC 12/24 V: operating voltage on standby, no error, DC 0 V: error, output switched off and manual "OFF"		
Switching element	Transistor, collector with pull-up resistance		
General			
Housing material	PA 6.6 (UL 94-V0; NFF I2, F2)		
Field installation	rail TS 35 (EN 60175)		
Protection class	IP 20		
Installation position	Optional		
Termination	Spring terminal 0.25–2.5 mm ²		
Operation temperature range	-25 °C – 50 °C		
Storage temperature range	-40 – 85 °C		
Dimensions (w × h × d) in mm	8.1 × 114.5 × 116.0		
Weight (kg/piece)	0.120		
Approvals	cULus, GL in preparation		
Standards	EN 60950-1; EN 61131-1,2; EN 61000; EN 60947-4-1; EN 55022		
Accessories			
0 V collective terminal	Color	Article number	Type
Supply terminal with cutout for copper rail to increase current		716420	LOCC Box-SK 7-6420
Distance terminal without contact		716421	LOCC Box-EKL 7-6421
LOCC Box empty housing without terminal		716422	LOCC Box-DKL 7-6422
Supply kit (supply and end terminals) 10 mm ²		716424	LOCC Box-DY 7-6424
Supply kit (supply and end terminals) 16 mm ²		716425	LOCC Box ES 7-6425
Jumper comb, 8-pin, 6 A	white	716427	LOCC Box ES 7-6427
Jumper comb, 8-pin, 6 A	red	716428	LOCC Box BKW 7-6428
Jumper comb, 8-pin, 6 A	blue	716429	LOCC Box BKR 7-6429
Jumper comb, 16-pin, 6 A	white	716430	LOCC Box BKB 7-6430
Jumper comb, 16-pin, 6 A	red	716438	LOCC Box BKW 7-6438
Jumper comb, 16-pin, 6 A	blue	716439	LOCC Box BKB 7-6440
Jumper comb, 16-pin, 6 A	blue	716440	LOCC Box BKR 7-6439
Tag holder (quantity 200)	white (5×5 mm)	716431	LOCC Box BZW 7-6431
Tag holder (quantity 200)	red (5×5 mm)	716432	LOCC Box BZR 7-6432
Tag holder (quantity 200)	blue (5×5 mm)	716433	LOCC Box BZB 7-6433
Tag holder (quantity 200)	yellow (5×5 mm)	716434	LOCC Box BZG 7-6434
Tag holder (quantity 120)	white (12×6 mm)	716441	LOCC Box BZW 7-6441
Tag holder	white (39.3×5 mm)	716443	LOCC Box BZW 7-6443
Cover for tag holder 716443	transparent	716444	LOCC Box-BAD 7-6444
A4 label sheets (quantity 240)	white	716445	LOCC Box-LEB 7-6445
Tag holder (quantity 50), printing 1–50	white	716446	LOCC Box BZW 7-6446
Copper rail, 1 m		716426	LOCC Box CU 7-6426
CU rail cover, 1 m		716427	LOCC Box AD 7-6427

Load monitoring · Microcompact LOCC-Box Class 2

Electronic load monitoring up to DC 24 A - DC 4 A
Single channel version, settable current range, settable characteristic
with current limitation acc. to NEC class 2



Dimensions

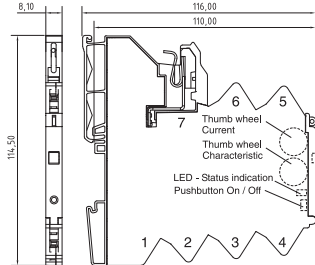

PIN assignment

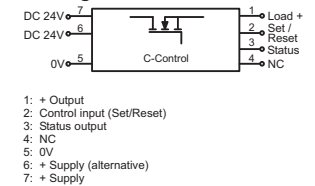

Signal output

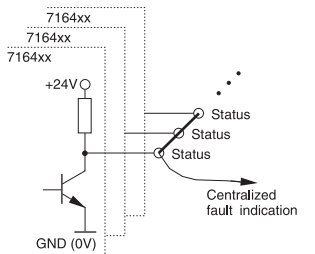
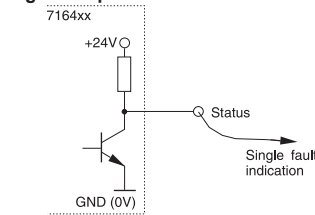

Description	Part-No.	Type	PU	
Spring terminal				
Nominal voltage	DC 12 / 24 V	716413	LOCC-Box-C2 7-6413	1
Input				
LOCC-Box-C2 7-6413				
Nominal voltage	DC 12 / 24 V			
Operation voltage range	DC 11 V – 30 V			
Rated current	DC 5 A			
Supply current	DC 40 A over Cu-rails 10 × 3 mm			
Reverse voltage protection	internal electronics			
Termination	screwless disconnect slide			
Control input (Set / Reset)				
Signal level	DC 24 V (EN 61131)			
OFF	Pulse with falling edge >100 ms, <800 ms			
ON	Pulse with falling edge > 1 s			
Output				
Switching element	MosFet			
Output current	max. DC 5 A			
Voltage drop	–			
Status Indication	LED green: Operating voltage present, no error LED red: Error in load circuit			
Switch-on capacity	4700 µF			
Current range	0.5 A – 4 A (can be set via switch in 0.5 A steps)			
Characteristic	fast (1), medium (2), slow 1 (3) see 'Characteristic curves'			
Signal output				
Signal level	DC 12/24 V: operating voltage on standby, no error, DC 0 V: error, output switched off and manual "OFF"			
Switching element	Transistor, collector with pull-up resistance			
General				
Housing material	PA 6.6 (UL 94-V0; NFF I2, F2)			
Field installation	rail TS 35 (EN 60175)			
Protection class	IP 20			
Installation position	Optional			
Termination	Spring terminal 0.25–2.5 mm ²			
Operation temperature range	–25 °C – 50 °C			
Storage temperature range	–40 – 75 °C			
Dimensions (w × h × d) in mm	8.1 × 114.5 × 116.0			
Weight (kg/piece)	0.120			
Approvals	cULus in progress, GL in progress, NEC class 2 in progress			
Standards	EN 60950-1; EN 61131-1,2; EN 61000; EN 60947-4-1; EN 55022			
Accessories				
0 V collective terminal	Color	Article number	Type	PU
Supply terminal with cutout for copper rail to increase current		716420	LOCC Box-SK 7-6420	2
Distance terminal without contact		716421	LOCC Box-EKL 7-6421	2
LOCC Box empty housing without terminal		716422	LOCC Box-DKL 7-6422	2
Supply kit (supply and end terminals) 10 mm ²		716424	LOCC Box-DY 7-6424	2
Supply kit (supply and end terminals) 16 mm ²		716425	LOCC Box ES 7-6425	1
Supply kit (supply and end terminals) 16 mm ²		716447	LOCC Box ES 7-6477	1
Jumper comb, 8-pin, 6 A	white	716428	LOCC Box BKW 7-6428	5
Jumper comb, 8-pin, 6 A	red	716429	LOCC Box BKR 7-6429	5
Jumper comb, 8-pin, 6 A	blue	716430	LOCC Box BKB 7-6430	5
Jumper comb, 16-pin, 6 A	white	716438	LOCC Box BKW 7-6438	5
Jumper comb, 16-pin, 6 A	red	716439	LOCC Box BKB 7-6440	5
Jumper comb, 16-pin, 6 A	blue	716440	LOCC Box BKR 7-6439	5
Tag holder (quantity 200)	white (5×5 mm)	716431	LOCC Box BZW 7-6431	1
Tag holder (quantity 200)	red (5×5 mm)	716432	LOCC Box BZR 7-6432	1
Tag holder (quantity 200)	blue (5×5 mm)	716433	LOCC Box BZB 7-6433	1
Tag holder (quantity 200)	yellow (5×5 mm)	716434	LOCC Box BZG 7-6434	1
Tag holder (quantity 120)	white (12×6 mm)	716441	LOCC Box BZW 7-6441	1
Tag holder	white (39.3×5 mm)	716443	LOCC Box BZW 7-6443	20
Cover for tag holder 716443	transparent	716444	LOCC Box-BAD 7-6444	20
A4 label sheets (quantity 240)	white	716445	LOCC Box-LEB 7-6445	10
Tag holder (quantity 50), printing 1–50	white	716446	LOCC Box BZW 7-6446	1
Copper rail, 1 m		716426	LOCC Box CU 7-6426	1
CU rail cover, 1 m		716427	LOCC Box AD 7-6427	1

Load monitoring · Microcompact LOCC Box-Net

Electronic load monitoring up to DC 10 A, with communication, parameterized
 Single-channel design, Adjustable current range: DC 1 A – 10 A
 Adjustable characteristics, fast, medium-speed, slow 1, -2, -3



Dimensions

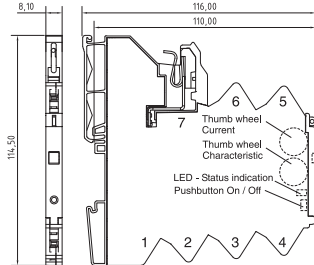

PIN assignment

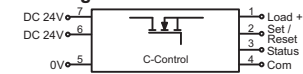

- 1: + Output
- 2: Control input (Set/Reset)
- 3: Status output
- 4: 1 Wire bus (Communication)
- 5: 0V
- 6: + Supply (alternative)
- 7: + Supply

Signal output

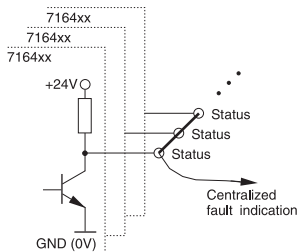
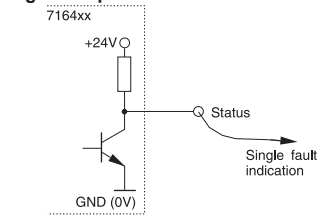

Description	Part-No.	Type	PU	
Spring terminal				
Nominal voltage	DC 12 / 24 V	716403	LOCC-Box-Net 7-6403	1
	DC 12 / 24 V	716404	LOCC-Box-Net 7-6404	1
Input				
	LOCC-Box-Net 7-6403		LOCC-Box-Net 7-6404	
Nominal voltage	DC 12 / 24 V			
Operation voltage range	DC 10 V – 32 V			
Rated current	DC 10 A			
Supply current	DC 40 A over Cu-rails 10 × 3 mm			
Reverse voltage protection	internal electronics			
Termination	screwless disconnect slide			
Control input (Set / Reset)				
Signal level	DC 12 / 24 V (EN 61131)			
OFF	Low level			
ON	High level (automatic reset)			
Output				
Switching element	MosFet			
Output current	max. DC 10 A			
Voltage drop	<170 mV (10 A)			
Status Indication	LED green: Operating voltage present, no error LED red: Error in load circuit			
Switch-on capacity	10000 µF			
Current range	1 A – 10 A (adjustable via switch in 1 A steps)			
Characteristic	fast acting (1), medium (2), slow 1 (3), slow 2 (4), slow 3 (5), can be configured (19) see 'Characteristic curves'			
Signal output				
Signal level	DC 12/24 V: Operating voltage present, no error; DC 0 V: error, output switched off, and manual "OFF" (parameterized)			
Switching element	Transistor, collector with pull-up resistance			
General				
Housing material	PA 6.6 (UL 94-V0; NFF I2, F2)			
Field installation	rail TS 35 (EN 60175)			
Protection class	IP 20			
Installation position	Optional			
Termination	Spring terminal 0.25–2.5 mm ²			
Operation temperature range	-25 °C – 50 °C			
Storage temperature range	-40 – 85 °C			
Dimensions (w × h × d) in mm	8.1 × 114.5 × 116.0			
Weight (kg/piece)	0.120			
Approvals	cULus, GL in preparation			
Standards	EN 60950-1; EN 61131-1,2; EN 61000; EN 60947-4-1; EN 55022			
Accessories				
	Color	Article number	Type	PU
0 V collective terminal		716420	LOCC Box-SK 7-6420	2
Supply terminal with cutout for copper rail to increase current		716421	LOCC Box-EKL 7-6421	2
Distance terminal without contact		716422	LOCC Box-DKL 7-6422	2
LOCC Box empty housing without terminal		716424	LOCC Box-DY 7-6424	2
Supply kit (supply and end terminals) 10 mm ²		716425	LOCC Box ES 7-6425	1
Supply kit (supply and end terminals) 16 mm ²		716447	LOCC Box ES 7-6477	1
Jumper comb, 8-pin, 6 A	white	716428	LOCC Box BKW 7-6428	5
Jumper comb, 8-pin, 6 A	red	716429	LOCC Box BKR 7-6429	5
Jumper comb, 8-pin, 6 A	blue	716430	LOCC Box BKB 7-6430	5
Jumper comb, 16-pin, 6 A	white	716438	LOCC Box BKW 7-6438	5
Jumper comb, 16-pin, 6 A	red	716439	LOCC Box BKB 7-6440	5
Jumper comb, 16-pin, 6 A	blue	716440	LOCC Box BKR 7-6439	5
Tag holder (quantity 200)	white (5×5 mm)	716431	LOCC Box BZW 7-6431	1
Tag holder (quantity 200)	red (5×5 mm)	716432	LOCC Box BZW 7-6432	1
Tag holder (quantity 200)	blue (5×5 mm)	716433	LOCC Box BZB 7-6433	1
Tag holder (quantity 200)	yellow (5×5 mm)	716434	LOCC Box BZG 7-6434	1
Tag holder (quantity 120)	white (12×6 mm)	716441	LOCC Box BZW 7-6441	1
Tag holder	white (39,3×5 mm)	716443	LOCC Box BZW 7-6443	20
Cover for tag holder 716443	transparent	716444	LOCC Box-BAD 7-6444	20
A4 label sheets (quantity 240)	white	716445	LOCC Box-LEB 7-6445	10
Tag holder (quantity 50), printing 1–50	white	716446	LOCC Box BZW 7-6446	1
Copper rail, 1 m		716426	LOCC Box CU 7-6426	1
CU rail cover, 1 m		716427	LOCC Box AD 7-6427	1

Load monitoring · Microcompact LOCC-Box-Net

Electronic load monitoring up to DC 10 A, with communication
 Single-channel design, programmable, Adjustable current range: DC 1 A – 10 A
 Adjustable characteristics, fast, medium-speed, slow 1, -2, -3



Dimensions

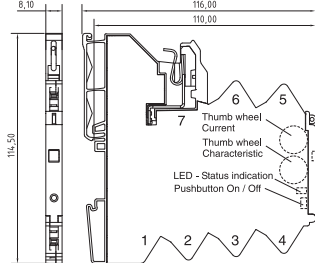

PIN assignment

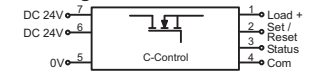

- 1: + Output
- 2: Control input (Set/Reset)
- 3: Status output
- 4: 1 Wire bus (Communication)
- 5: 0V
- 6: + Supply (alternative)
- 7: + Supply

Signal output

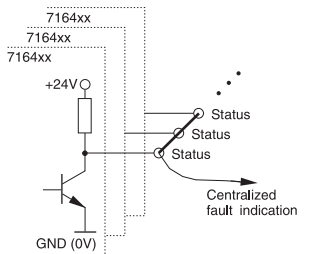
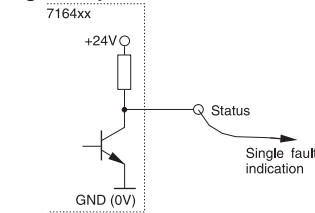

Description	Part-No.	Type	PU	
Spring terminal				
Nominal voltage	DC 12 / 24 V	716410	LOCC-Box-Net 7-6410	1
	DC 12 / 24 V	716410.0050	LOCC-Box-Net 7-6410	50

Input			
LOCC-Box-Net 7-6410			
Nominal voltage	DC 12 / 24 V		
Operation voltage range	DC 10 V – 30 V		
Rated current	DC 10 A		
Supply current	DC 40 A over Cu rail 10 × 3 mm		
Reverse voltage protection	internal electronics		
Termination	screwless disconnect slide		

Control input (Set / Reset)			
Signal level	DC 12 / 24 V (EN 61131)		
OFF	Pulse with falling edge >100 ms, <800 ms		
ON	Pulse with falling edge > 1 s		

Output			
Switching element	MosFet		
Output current	max. DC 10 A		
Voltage drop	<170 mV (10 A)		
Status Indication	LED green: Operating voltage present, no error LED red: Error in load circuit		
Switch-on capacity	10000 µF		
Current range	1 A – 10 A (adjustable via switch in 1 A steps)		
Characteristic	fast acting (1), medium (2), slow 1 (3), slow 2 (4), slow 3 (5), can be configured (19) see 'Characteristic curves'		

Signal output			
Signal level	DC 12/24 V: Operating voltage present, no error; DC 0 V: error, output switched off, and manual "OFF" (parameterized)		
Switching element	Transistor, collector with pull-up resistance		

General			
Housing material	PA 6.6 (UL 94-V0; NFF I2, F2)		
Field installation	rail TS 35 (EN 60175)		
Protection class	IP 20		
Installation position	Optional		
Termination	Spring terminal 0.25–2.5 mm ²		
Operation temperature range	-25 °C – 50 °C		
Storage temperature range	-40 – 85 °C		
Dimensions (w × h × d) in mm	8.1 × 114.5 × 116.0		
Weight (kg/piece)	0.120		
Approvals	cULus, GL in preparation		
Standards	EN 60950-1; EN 61131-1,2; EN 61000; EN 60947-4-1; EN 55022		

Accessories	Color	Article number	Type	PU
0 V collective terminal		716420	LOCC Box-SK 7-6420	2
Supply terminal with cutout for copper rail to increase current		716421	LOCC Box-EKL 7-6421	2
Distance terminal without contact		716422	LOCC Box-DKL 7-6422	2
LOCC Box empty housing without terminal		716424	LOCC Box-DY 7-6424	2
Supply kit (supply and end terminals) 10 mm ²		716425	LOCC Box ES 7-6425	1
Supply kit (supply and end terminals) 16 mm ²		716447	LOCC Box ES 7-6477	1
Jumper comb, 8-pin, 6 A	white	716428	LOCC Box BKW 7-6428	5
Jumper comb, 8-pin, 6 A	red	716429	LOCC Box BKR 7-6429	5
Jumper comb, 8-pin, 6 A	blue	716430	LOCC Box BKB 7-6430	5
Jumper comb, 16-pin, 6 A	white	716438	LOCC Box BKW 7-6438	5
Jumper comb, 16-pin, 6 A	red	716439	LOCC Box BKB 7-6440	5
Jumper comb, 16-pin, 6 A	blue	716440	LOCC Box BKR 7-6439	5
Tag holder (quantity 200)	white (5×5 mm)	716431	LOCC Box BZW 7-6431	1
Tag holder (quantity 200)	red (5×5 mm)	716432	LOCC Box BZR 7-6432	1
Tag holder (quantity 200)	blue (5×5 mm)	716433	LOCC Box BZB 7-6433	1
Tag holder (quantity 200)	yellow (5×5 mm)	716434	LOCC Box BZG 7-6434	1
Tag holder (quantity 120)	white (12×6 mm)	716441	LOCC Box BZW 7-6441	1
Tag holder	white (39.3×5 mm)	716443	LOCC Box BZW 7-6443	20
Cover for tag holder 716443	transparent	716444	LOCC Box-BAD 7-6444	20
A4 label sheets (quantity 240)	white	716445	LOCC Box-LEB 7-6445	10
Tag holder (quantity 50), printing 1–50	white	716446	LOCC Box BZW 7-6446	1
Copper rail, 1 m		716426	LOCC Box CU 7-6426	1
CU rail cover, 1 m		716427	LOCC Box AD 7-6427	1

Load monitoring · Microcompact LOCC Box-Net

Electronic load monitoring up to DC 10 A, with communication, without rotary switch
 Single-channel design, Adjustable current range: DC 1 A – 10 A
 Adjustable characteristic: fast, middle, slow 1, -2, -3 (see Software)



Dimensions

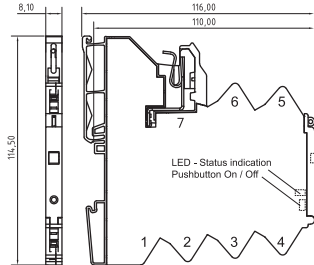

PIN assignment

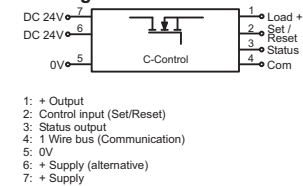

Signal output

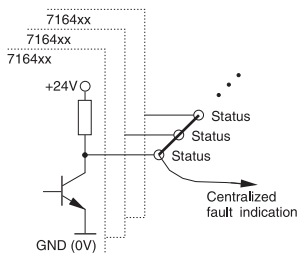
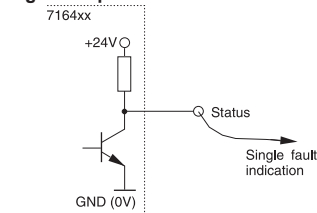

Description	Part-No.	Type	PU	
Nominal voltage	DC 12 / 24 V	716411	LOCC-Box-Net 7-6411	1
Input				
LOCC-Box-Net 7-6411				
Nominal voltage	DC 12 / 24 V			
Operation voltage range	DC 10 V – 32 V			
Rated current	DC 10 A			
Supply current	DC 40 A over Cu-rails 10 × 3 mm			
Reverse voltage protection	internal electronics			
Termination	screwless disconnect slide			
Control input (Set / Reset)				
Signal level	DC 12 / 24 V (EN 61131)			
OFF	Pulse with falling edge >100 ms, <800 ms			
ON	Pulse with falling edge > 1 s			
Output				
Switching element	MosFet			
Output current	max. DC 10 A			
Voltage drop	<170 mV (10 A)			
Status Indication	LED green: Operating voltage present, no error LED red: Error in load circuit			
Switch-on capacity	10000 µF			
Current range	1 A – 10 A (adjustable via software, EtherCAT, Profibus, CANopen)			
Characteristic	fast (1), middle (2), slow 1 (3), slow 2 (4), slow 3 (5), (adjustable via software, EtherCAT, Profibus, CANopen), see 'characteristic curves'			
Signal output				
Signal level	DC 12/24 V: Operating voltage present, no error; DC 0 V: error, output switched off, and manual "OFF" (parameterized)			
Switching element	Transistor, collector with pull-up resistance			
General				
Housing material	PA 6.6 (UL 94-V0; NFF I2, F2)			
Field installation	rail TS 35 (EN 60175)			
Protection class	IP 20			
Installation position	Optional			
Termination	Spring terminal 0.25–2.5 mm ²			
Operation temperature range	-25 °C – 50 °C			
Storage temperature range	-40 – 80 °C			
Dimensions (w × h × d) in mm	8.1 × 114.5 × 116.0			
Weight (kg/piece)	0.120			
Approvals	cULus, GL in preparation			
Standards	EN 60950-1; EN 61131-1,2; EN 61000; EN 60947-4-1; EN 55022			
Accessories				
0 V collective terminal	Color	Article number	Type	PU
Supply terminal with cutout for copper rail to increase current		716420	LOCC Box-SK 7-6420	2
Distance terminal without contact		716421	LOCC Box-EKL 7-6421	2
LOCC Box empty housing without terminal		716422	LOCC Box-DKL 7-6422	2
LOCC Box empty housing without terminal		716424	LOCC Box-DY 7-6424	2
Supply kit (supply and end terminals) 10 mm ²		716425	LOCC Box ES 7-6425	1
Supply kit (supply and end terminals) 16 mm ²		716447	LOCC Box ES 7-6477	1
Jumper comb, 8-pin, 6 A	white	716428	LOCC Box BKW 7-6428	5
Jumper comb, 8-pin, 6 A	red	716429	LOCC Box BKR 7-6429	5
Jumper comb, 8-pin, 6 A	blue	716430	LOCC Box BKB 7-6430	5
Jumper comb, 16-pin, 6 A	white	716438	LOCC Box BKW 7-6438	5
Jumper comb, 16-pin, 6 A	red	716439	LOCC Box BKB 7-6440	5
Jumper comb, 16-pin, 6 A	blue	716440	LOCC Box BKR 7-6439	5
Tag holder (quantity 200)	white (5×5 mm)	716431	LOCC Box BZW 7-6431	1
Tag holder (quantity 200)	red (5×5 mm)	716432	LOCC Box BZR 7-6432	1
Tag holder (quantity 200)	blue (5×5 mm)	716433	LOCC Box BZB 7-6433	1
Tag holder (quantity 200)	yellow (5×5 mm)	716434	LOCC Box BZG 7-6434	1
Tag holder (quantity 120)	white (12×6 mm)	716441	LOCC Box BZW 7-6441	1
Tag holder	white (39.3×5 mm)	716443	LOCC Box BZW 7-6443	20
Cover for tag holder 716443	transparent	716444	LOCC Box-BAD 7-6444	20
A4 label sheets (quantity 240)	white	716445	LOCC Box-LEB 7-6445	10
Tag holder (quantity 50), printing 1–50	white	716446	LOCC Box BZW 7-6446	1
Copper rail, 1 m		716426	LOCC Box CU 7-6426	1
CU rail cover, 1 m		716427	LOCC Box AD 7-6427	1

Load monitoring · Microcompact LOCC-Box-SC

Electronic load monitoring up to DC 5 A, with communication
 Single-channel design, Adjustable current range: DC 1 A – 5 A
 Adjustable characteristics, fast, medium-speed, slow 1



Dimensions

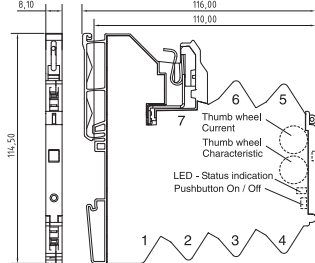

PIN assignment

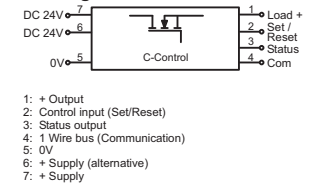

Signal output

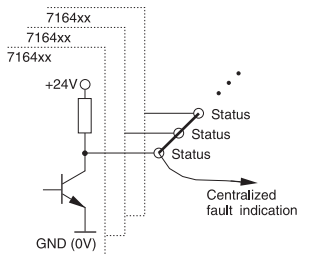
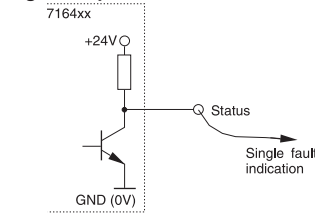

Description	Part-No.	Type	PU	
Spring terminal				
Nominal voltage	DC 12 / 24 V	716418	LOCC-Box-Net-SC 7-6418	1
Input				
LOCC-Box-Net-SC 7-6418				
Nominal voltage	DC 12 / 24 V			
Operation voltage range	DC 10 V – 30 V			
Rated current	DC 5 A			
Supply current	DC 40 A over Cu-rails 10 × 3 mm			
Reverse voltage protection	internal electronics			
Termination	screwless disconnect slide			
Control input (Set / Reset)				
Signal level	DC 12 / 24 V (EN 61131)			
OFF	Pulse with falling edge >100 ms, <800 ms			
ON	Pulse with falling edge > 1 s			
Output				
Switching element	MosFet			
Output current	max. DC 5 A			
Voltage drop	<85 mV (5 A)			
Status Indication	LED green: Operating voltage present, no error LED red: Error in load circuit			
Switch-on capacity	Optional µF			
Current range	1 A – 5 A (adjustable via switch in 1 A steps)			
Characteristic	fast (1), medium (2), slow 1 (3) see 'Characteristic curves'			
Signal output				
Signal level	DC 12/24 V: Operating voltage present, no error; DC 0 V: error, output switched off, and manual "OFF" (parameterized)			
Switching element	Transistor, collector with pull-up resistance			
General				
Housing material	PA 6.6 (UL 94-V0; NFF I2, F2)			
Field installation	rail TS 35 (EN 60175)			
Protection class	IP 20			
Installation position	Optional			
Termination	Spring terminal 0.25–2.5 mm ²			
Operation temperature range	-25 °C – 50 °C			
Storage temperature range	-40 – 85 °C			
Dimensions (w × h × d) in mm	8.1 × 114.5 × 116.0			
Weight (kg/piece)	0.120			
Approvals	cULus, GL in preparation			
Standards	EN 60950-1; EN 61131-1,2; EN 61000; EN 60947-4-1; EN 55022			
Accessories				
0 V collective terminal	Color	Article number	Type	PU
Supply terminal with cutout for copper rail to increase current		716420	LOCC Box-SK 7-6420	2
Distance terminal without contact		716421	LOCC Box-EKL 7-6421	2
LOCC Box empty housing without terminal		716422	LOCC Box-DKL 7-6422	2
LOCC Box empty housing without terminal		716424	LOCC Box-DY 7-6424	2
Supply kit (supply and end terminals) 10 mm ²		716425	LOCC Box ES 7-6425	1
Supply kit (supply and end terminals) 16 mm ²		716447	LOCC Box ES 7-6477	1
Jumper comb, 8-pin, 6 A	white	716428	LOCC Box BKW 7-6428	5
Jumper comb, 8-pin, 6 A	red	716429	LOCC Box BKR 7-6429	5
Jumper comb, 8-pin, 6 A	blue	716430	LOCC Box BKB 7-6430	5
Jumper comb, 16-pin, 6 A	white	716438	LOCC Box BKW 7-6438	5
Jumper comb, 16-pin, 6 A	red	716439	LOCC Box BKB 7-6440	5
Jumper comb, 16-pin, 6 A	blue	716440	LOCC Box BKR 7-6439	5
Tag holder (quantity 200)	white (5×5 mm)	716431	LOCC Box BZW 7-6431	1
Tag holder (quantity 200)	red (5×5 mm)	716432	LOCC Box BZR 7-6432	1
Tag holder (quantity 200)	blue (5×5 mm)	716433	LOCC Box BZB 7-6433	1
Tag holder (quantity 200)	yellow (5×5 mm)	716434	LOCC Box BZG 7-6434	1
Tag holder (quantity 120)	white (12×6 mm)	716441	LOCC Box BZW 7-6441	1
Tag holder	white (39.3×5 mm)	716443	LOCC Box BZW 7-6443	20
Cover for tag holder 716443	transparent	716444	LOCC Box-BAD 7-6444	20
A4 label sheets (quantity 240)	white	716445	LOCC Box-LEB 7-6445	10
Tag holder (quantity 50), printing 1–50	white	716446	LOCC Box BZW 7-6446	1
Copper rail, 1 m		716426	LOCC Box CU 7-6426	1
CU rail cover, 1 m		716427	LOCC Box AD 7-6427	1

Load monitoring · Microcompact LOCC-Box-Net Class 2

Electronic load monitoring up to DC 24 A - DC 4 A, with communication
Single channel version, settable current range, settable characteristic
with current limitation acc. to NEC class 2



Dimensions

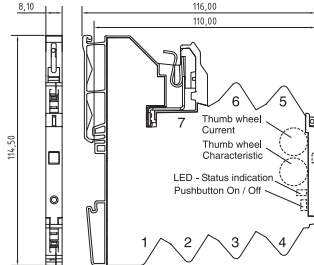

PIN assignment

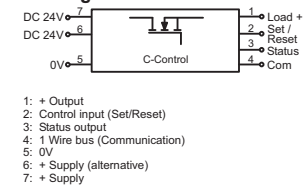

- 1: + Output
- 2: Control input (Set/Reset)
- 3: Status output
- 4: 1 Wire bus (Communication)
- 5: 0V
- 6: + Supply (alternative)
- 7: + Supply

Signal output

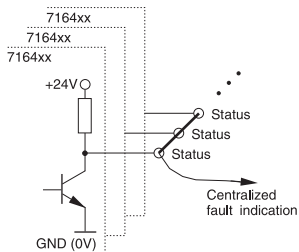
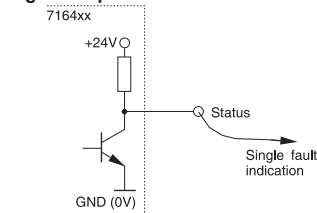

Description	Part-No.	Type	PU	
Spring terminal				
Nominal voltage	DC 12 / 24 V	716414	LOCC-Box-C2 NET 7-6414	1
Input				
LOCC-Box-C2 NET 7-6414				
Nominal voltage	DC 12 / 24 V			
Operation voltage range	DC 11 V – 30 V			
Rated current	DC 5 A			
Supply current	DC 40 A over Cu-rails 10 × 3 mm			
Reverse voltage protection	internal electronics			
Termination	screwless disconnect slide			
Control input (Set / Reset)				
Signal level	DC 24 V (EN 61131)			
OFF	Pulse with falling edge >100 ms, <800 ms			
ON	Pulse with falling edge > 1 s			
Output				
Switching element	MosFet			
Output current	max. DC 5 A			
Voltage drop	-			
Status Indication	LED green: Operating voltage present, no error LED red: Error in load circuit			
Switch-on capacity	4700 µF			
Current range	0.5 A – 4 A (can be set via switch in 0.5 A steps)			
Characteristic	fast (1), medium (2), slow 1 (3) see 'Characteristic curves'			
Signal output				
Signal level	DC 24 V: Operating voltage present, no error; DC 0 V: error, output switched off and manual "OFF"			
Switching element	Transistor, collector with pull-up resistance			
General				
Housing material	PA 6.6 (UL 94-V0; NFF I2, F2)			
Field installation	rail TS 35 (EN 60175)			
Protection class	IP 20			
Installation position	Optional			
Termination	Spring terminal 0.25–2.5 mm ²			
Operation temperature range	-25 °C – 50 °C			
Storage temperature range	-40 – 75 °C			
Dimensions (w × h × d) in mm	8.1 × 114.5 × 116.0			
Weight (kg/piece)	0.120			
Approvals	cULus in progress, GL in progress, NEC class 2 in progress			
Standards	EN 60950-1; EN 61131-1,2; EN 61000; EN 60947-4-1; EN 55022			

Accessories	Color	Article number	Type	PU
0 V collective terminal		716420	LOCC Box-SK 7-6420	2
Supply terminal with cutout for copper rail to increase current		716421	LOCC Box-EKL 7-6421	2
Distance terminal without contact		716422	LOCC Box-DKL 7-6422	2
LOCC Box empty housing without terminal		716424	LOCC Box-DY 7-6424	2
Supply kit (supply and end terminals) 10 mm ²		716425	LOCC Box ES 7-6425	1
Supply kit (supply and end terminals) 16 mm ²		716447	LOCC Box ES 7-6477	1
Jumper comb, 8-pin, 6 A	white	716428	LOCC Box BKW 7-6428	5
Jumper comb, 8-pin, 6 A	red	716429	LOCC Box BKR 7-6429	5
Jumper comb, 8-pin, 6 A	blue	716430	LOCC Box BKB 7-6430	5
Jumper comb, 16-pin, 6 A	white	716438	LOCC Box BKW 7-6438	5
Jumper comb, 16-pin, 6 A	red	716439	LOCC Box BKB 7-6440	5
Jumper comb, 16-pin, 6 A	blue	716440	LOCC Box BKR 7-6439	5
Tag holder (quantity 200)	white (5×5 mm)	716431	LOCC Box BZW 7-6431	1
Tag holder (quantity 200)	red (5×5 mm)	716432	LOCC Box BZR 7-6432	1
Tag holder (quantity 200)	blue (5×5 mm)	716433	LOCC Box BZB 7-6433	1
Tag holder (quantity 200)	yellow (5×5 mm)	716434	LOCC Box BZG 7-6434	1
Tag holder (quantity 120)	white (12×6 mm)	716441	LOCC Box BZW 7-6441	1
Tag holder	white (39.3×5 mm)	716443	LOCC Box BZW 7-6443	20
Cover for tag holder 716443	transparent	716444	LOCC Box-BAD 7-6444	20
A4 label sheets (quantity 240)	white	716445	LOCC Box-LEB 7-6445	10
Tag holder (quantity 50), printing 1–50	white	716446	LOCC Box BZW 7-6446	1
Copper rail, 1 m		716426	LOCC Box CU 7-6426	1
CU rail cover, 1 m		716427	LOCC Box AD 7-6427	1

Load monitoring · Microcompact gateway

Gateway for LOCC-Box-Net (716410)

Input: LOCCbus (LIN)

Output: USB, RS 232, CANopen



Dimensions

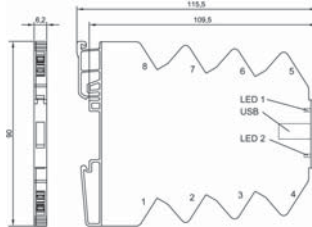

PIN assignment

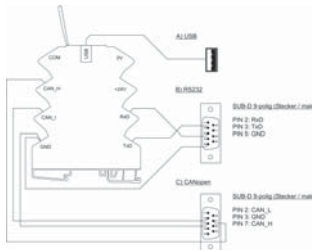

Description	Part-No.	Type	PU	
Spring terminal				
Nominal voltage	DC 12 / 24 V	716459	LOCC-Box-GW 7-6459	1
Input				
LOCC-Box-GW 7-6459				
Bus system	LOCCbus, basic LIN			
Access method	Single-Master - Multiple Slave			
Bus technology	Line			
Physical level	1-wire			
Participants	40, max. 254			
Bus length	max. 40 m			
Transfer rate	9600 Baud			
Data rate	8 Bit + fixed parity			
Transfer protocol	Modified multi-drop			
Output				
Bus system	USB 2.0 Full-Speed	RS232	CANopen	
Transfer rate	12 Mbit/s	600 – 11500 bit/s	10 – 1000 kbit/s	
General				
Nominal voltage	DC 12 / 24 V			
Operation voltage range	DC 10 V – 26.4 V			
Rated current	max. 50 mA			
Reverse voltage protection	Yes			
Status Indication	LED 1 green/red: USB, RS232, Firmware; LED 2 green/red: CANopen			
Insulation voltage	1.0 kV			
Housing material	PA 6.6 (UL 94-V0; NFF I2, F2)			
Field installation	rail TS 35 (EN 60175)			
Protection class	IP 20			
Installation position	Optional			
Termination	Spring terminal : 0.14 - 2.5 mm ² (with AE 1.5 mm ²)			
Operation temperature range	-20 °C – 60 °C			
Storage temperature range	-40 – 85 °C			
Dimensions (w × h × d) in mm	6.2 × 90.0 × 115.0			
Weight (kg/piece)	0.060			
Approvals	CE			
Standards	EN 60950-1, EN 61131-1, -2, EN 60898, EN 60947-4-1, EN 50081			
Accessories				
Tag holder 4×11 mm	Color	Article number	Type	PU
	white	681313	BZT 0411	100
Isolation plate		760809	TP 7-0809	5
Labels for laser printer A4 unpunched		681031	LEB - A4	1

Load monitoring · Gateway

Gateway for LOCC-Box-Net (716410)

Input: LOCCbus (LIN)

Output: USB, PROFINET-IO



Dimensions

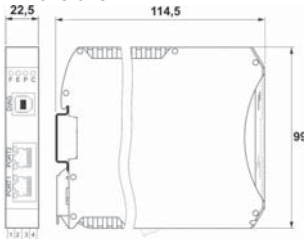

PIN assignment

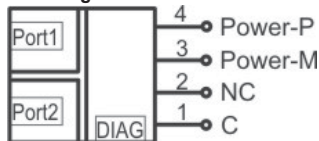

Description	Part-No.	Type	PU
Spring terminal			
Nominal voltage	DC 12 / 24 V	716457	LOCC-Box-GWPN 0-6457
Input			
Bus system	LOCCbus, basic LIN		
Access method	Single-Master - Multiple Slave		
Bus technology	Line		
Physical level	1-wire		
Participants	typ. 40, max. 100		
Bus length	max. 40 m		
Transfer rate	9600 Baud		
Data rate	8 Bit + fixed parity (Bit 9)		
Transfer protocol	Modified multi-drop		
Output			
Bus system	USB 2.0 Full-Speed	PROFINET-IO	
Transfer rate	12 Mbit/s	100 bit/s (IEE 802.3)	
Interface	USB connector, Type B	Port_1, Port_2, 2 × RJ-45 female with galvanic isolation and LEDs	
General			
Nominal voltage	DC 12 / 24 V		
Operation voltage range	10 – 32 V		
Rated current	120 mA @ 24 V		
Reverse voltage protection	Yes		
Status Indication	LED F, yellow - flashing: identification prompt (PROFINET) LED E, red - flashing: no connection (PROFINET) LED P, green - flashing: operating voltage is connected (POWER) LED C, green - flashing: data traffic with LOCC Box Net modules (LOCCbus) Link: yellow - 100Base/T-connection Activity green - valid connection, blanking: data traffic		
Insulation voltage	1.5 kV		
Housing material	PA (UL94-V0)		
Field installation	rail TS 35 (EN 60175)		
Protection class	IP 20		
Installation position	Optional		
Termination	Spring terminal : 0.14 - 2.5 mm ² (with AE 1.5 mm ²)		
Relative humidity	max. 90 % non-condensed		
Operation temperature range	-20 °C – 60 °C		
Storage temperature range	-40 – 85 °C		
Dimensions (w × h × d) in mm	22.5 × 99.0 × 114.5		
Weight (kg/piece)	0.130		
Approvals	CE		
Standards	EN 60950-1, EN 61131-1, -2, EN 60898, EN 60947-4-1, EN 50081		
Comments			
Screw terminal on request			

Use

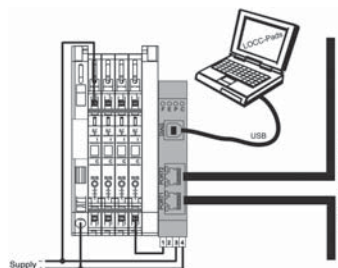

Load monitoring · Gateway

Gateway for LOCC-Box-Net (716410)

Input: LOCCbus (LIN)

Output: USB, PROFIBUS-DP



Dimensions

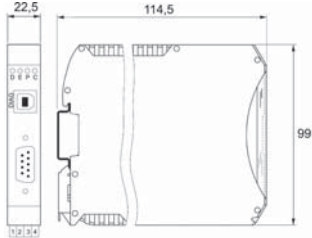

PIN assignment

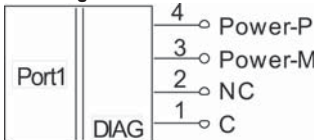

Description	Part-No.	Type	PU	
Spring terminal				
Nominal voltage	DC 12 / 24 V	716458	LOCC-Box-GWPB 0-6458	1
Input				
Bus system	LOCCbus, basic LIN			
Access method	Single-Master - Multiple Slave			
Bus technology	Line			
Physical level	1-wire			
Participants	typ. 40, max. 84			
Bus length	max. 40 m			
Transfer rate	9600 Baud			
Data rate	8 Bit + fixed parity (Bit 9)			
Transfer protocol	Modified multi-drop			
Output				
Bus system	USB 2.0 Full-Speed	PROFIBUS-DP		
Transfer rate	12 Mbit/s	max. 12 Mbit/s		
Interface	USB connector, Type B	Port_1, SUB-D 9pin with galvanic isolation		
General				
Nominal voltage	DC 12 / 24 V			
Operation voltage range	10 – 32 V			
Rated current	120 mA @ 24 V			
Reverse voltage protection	Yes			
Status Indication	LED D, green - on: data exchange via PROFIBUS-DP LED E, red - different flash codes for diagnosis of PROFIBUS-DP faults LED P, green - on: operating voltage is supplied (POWER) LED C, green - flashing: data traffic with LOCC-Box-Net modules (LOCCbus)			
Insulation voltage	1.5 kV			
Housing material	PA (UL94-V0)			
Field installation	rail TS 35 (EN 60175)			
Protection class	IP 20			
Installation position	Optional			
Termination	Spring terminal : 0.14 - 2.5 mm ² (with AE 1.5 mm ²)			
Relative humidity	max. 90 % non-condensed			
Operation temperature range	-20 °C – 60 °C			
Storage temperature range	-40 – 85 °C			
Dimensions (w × h × d) in mm	22.5 × 99.0 × 114.5			
Weight (kg/piece)	0.130			
Approvals	CE			
Standards	EN 60950-1, EN 61131-1, EN 61000, EN 60947-4-1, EN 50016			
Comments				
Screw terminal on request				

Use

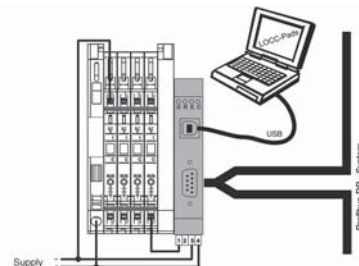

Load monitoring · Gateway

Gateway for LOCC-Box-Net (716410)

Input: LOCCbus (LIN)

Output: USB, EtherCAT



Dimensions

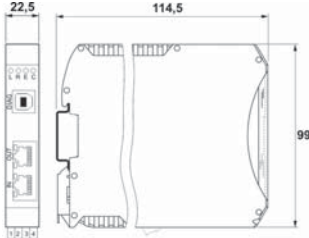

PIN assignment

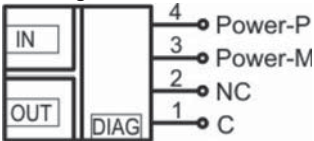

Description	Part-No.	Type	PU
Spring terminal			
Nominal voltage	DC 12 / 24 V	716456	LOCC-Box-GWEC 0-6456
1			
Input			
Bus system	LOCCbus, basic LIN		
Access method	Single-Master - Multiple Slave		
Bus technology	Line		
Physical level	1-wire		
Participants	typ. 40, max. 64		
Bus length	max. 40 m		
Transfer rate	9600 Baud		
Data rate	8 Bit + fixed parity (Bit 9)		
Transfer protocol	Modified multi-drop		
Output			
Bus system	USB 2.0 Full-Speed	EtherCAT	
Transfer rate	12 Mbit/s	100 bit/s (IEE 802.3)	
Interface	USB connector, Type B	IN, OUT, 2 × RJ-45 female with galvanic isolation and LEDs	
General			
Nominal voltage	DC 12 / 24 V		
Operation voltage range	10 – 32 V		
Rated current	55 mA @ 24 V		
Reverse voltage protection	Yes		
Status Indication	LED L, red - flashing: EEPROM error, EEPROM not loaded LED R, green - lit: ECT Run LED E, green - lit: ECT error LED C, green - flashing: data traffic with LOCC Box-Net modules (LOCCbus) link/activity: green - 100Base/T-connection, flashes with EtherCAT traffic Connect: yellow - speed LED, 100Base/T-connection		
Insulation voltage	1.5 kV		
Housing material	PA (UL94-V0)		
Field installation	rail TS 35 (EN 60175)		
Protection class	IP 20		
Installation position	Optional		
Termination	Spring terminal : 0.14 - 2.5 mm ² (with AE 1.5 mm ²)		
Relative humidity	max. 90 % non-condensed		
Operation temperature range	-20 °C – 60 °C		
Storage temperature range	-40 – 85 °C		
Dimensions (w × h × d) in mm	22.5 × 99.0 × 114.5		
Weight (kg/piece)	0.130		
Approvals	CE		
Standards	EN 60950-1, EN 61131-1, -2, EN 60898, EN 60947-4-1, EN 50081		
Comments			
Screw terminal on request			

Use

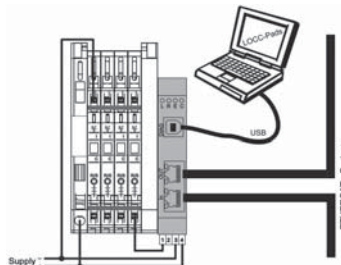

Load monitoring · Accessories

LOCC-Box supply set consisting of supply terminal and end block maximum total current 40 A



Dimensions Supply terminal

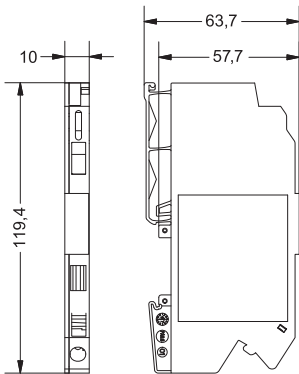

End block

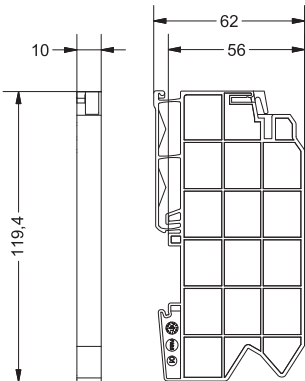

Description	Part-No.	Type	PU	
Nominal voltage	DC 12 / 24 V	716425	LOCC-Box-ES 7-6425	1
Input				
LOCC-Box-ES 7-6425				
Nominal voltage	DC 12 / 24 V			
Rated current	max. DC 40 A			
Reverse voltage protection	No			
Termination	Spring terminal : 0.33 – 10 mm ² (AWG 22–8) conductor connection cross section, single wire (solid): max. 10 mm ² conductor connection cross section, fine wire: max. 6 mm ² conductor connection cross section, fine wire with AEH: max. 6 mm ²			
Length of stripped insulation	12 mm			
Output				
Nominal voltage	DC 12 / 24 V			
Output current	max. DC 40 A			
Termination	screwless disconnect terminal			
Copper bus bar	3 × 10mm			
General				
Housing material	PA 6.6 (UL 94-V0; NFF I2, F2)			
Field installation	rail TS 35 (EN 60175)			
Protection class	IP 20			
Installation position	Optional			
Operation temperature range	-25 °C – 60 °C			
Storage temperature range	-40 – 85 °C			
Dimensions (w × h × d) in mm	10.0 × 119.4 × 63.7			
Weight (kg/piece)	0.035			
Approvals	cULus			
Standards	–			

Load monitoring · Accessories

LOCC Box supply terminal maximum total current 40 A



Dimensions

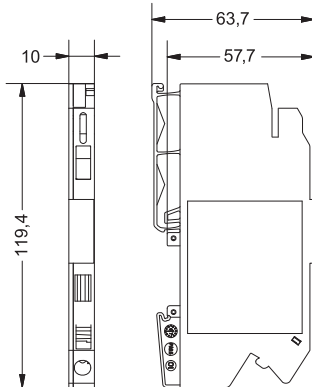

Description	Part-No.	Type	PU	
Nominal voltage	DC 12 / 24 V	716435	LOCC-Box-EKL 7-6435	2
Input				
LOCC-Box-EKL 7-6435				
Nominal voltage	DC 12 / 24 V			
Rated current	max. DC 40 A			
Reverse voltage protection	No			
Termination	Spring terminal : 0.33 – 10 mm ² (AWG 22–8) conductor connection cross section, single wire (solid): max. 10 mm ² conductor connection cross section, fine wire: max. 6 mm ² conductor connection cross section, fine wire with AEH: max. 6 mm ²			
Length of stripped insulation	12 mm			
Output				
Nominal voltage	DC 12 / 24 V			
Output current	max. DC 40 A			
Termination	screwless disconnect terminal			
Copper bus bar	3 × 10mm			
General				
Housing material	PA 6.6 (UL 94-V0; NFF I2, F2)			
Field installation	rail TS 35 (EN 60175)			
Protection class	IP 20			
Installation position	Optional			
Operation temperature range	-25 °C – 60 °C			
Storage temperature range	-40 – 85 °C			
Dimensions (w × h × d) in mm	10.0 × 119.4 × 63.7			
Weight (kg/piece)	0.035			
Approvals	cULus			
Standards	-			

Load monitoring · Accessories

LOCC Box end block



Dimensions

End block

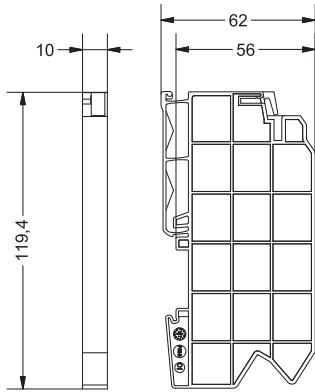

Description	Part-No.	Type	PU
Nominal voltage	716436	LOCC-Box-EB 7-6436	2
General			
Housing material	PA 6.6 (UL 94-V0; NFF I2, F2)		
Field installation	rail TS 35 (EN 60175)		
Protection class	IP 20		
Installation position	Optional		
Operation temperature range	-25 °C – 60 °C		
Storage temperature range	-40 – 85 °C		
Dimensions (w × h × d) in mm	10.0 × 119.4 × 62.0		
Weight (kg/piece)	0.010		
Approvals	cULus		
Standards	-		

Load monitoring - Accessories

LOCC-Box supply terminal Additional supply terminal for increased current maximum total current 40 A



Dimensions

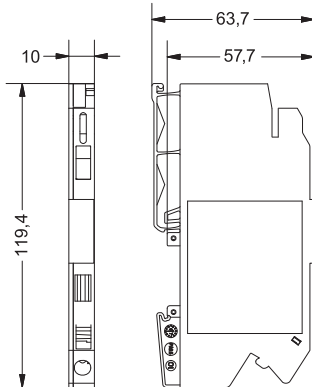

Use



Description	Part-No.	Type	PU	
Nominal voltage	DC 12 / 24 V	716421	LOCC-Box-EKL 7-6421	2
Input		LOCC-Box-EKL 7-6421		
Nominal voltage	DC 12 / 24 V			
Rated current	max. DC 40 A			
Reverse voltage protection	No			
Termination	Spring terminal : 0.33 – 10 mm ² (AWG 22–8) conductor connection cross section, single wire (solid): max. 10 mm ² conductor connection cross section, fine wire: max. 6 mm ² conductor connection cross section, fine wire with AEH: max. 6 mm ²			
Length of stripped insulation	12 mm			
Output				
Nominal voltage	DC 12 / 24 V			
Output current	max. DC 40 A			
Termination	screwless disconnect terminal			
Copper bus bar	3 × 10mm			
General				
Housing material	PA 6.6 (UL 94-V0; NFF I2, F2)			
Field installation	rail TS 35 (EN 60175)			
Protection class	IP 20			
Installation position	Optional			
Operation temperature range	-25 °C – 60 °C			
Storage temperature range	-40 – 85 °C			
Dimensions (w × h × d) in mm	10.0 × 119.4 × 63.7			
Weight (kg/piece)	0.035			
Approvals	cULus			
Standards	-			

Load monitoring · Accessories

LOCC-Box supply set consisting of supply terminal and end block maximum total current 40 A



Dimensions Supply terminal

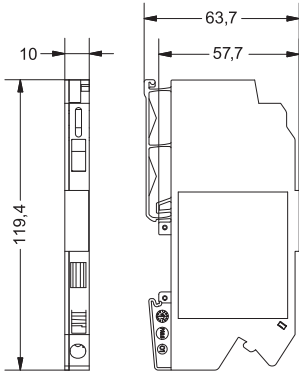

End block

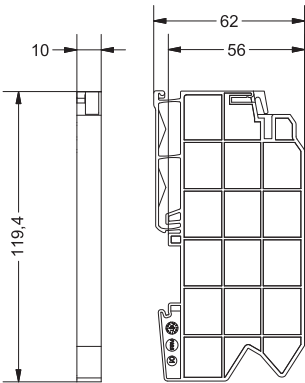

Description	Part-No.	Type	PU	
Nominal voltage	DC 12 / 24 V	716447	LOCC-Box-ES 7-6447	1
Input				
LOCC-Box-ES 7-6447				
Nominal voltage	DC 12 / 24 V			
Rated current	max. DC 40 A			
Reverse voltage protection	No			
Termination	Spring terminal : 0.33 – 16 mm ² (AWG 22–6) conductor connection cross section, single wire (solid): max. 16 mm ² conductor connection cross section, fine wire: max. 10 mm ² conductor connection cross section, fine wire with AEH: max. 10 mm ²			
Length of stripped insulation	12 mm			
Output				
Nominal voltage	DC 12 / 24 V			
Output current	max. DC 40 A			
Termination	screwless disconnect terminal			
Copper bus bar	3 × 10mm			
General				
Housing material	PA 6.6 (UL 94-V0; NFF I2, F2)			
Field installation	rail TS 35 (EN 60175)			
Protection class	IP 20			
Installation position	Optional			
Operation temperature range	-25 °C – 60 °C			
Storage temperature range	-40 – 85 °C			
Dimensions (w × h × d) in mm	10.0 × 119.4 × 63.7			
Weight (kg/piece)	–			
Approvals	cULus			
Standards	–			

Load monitoring · Accessories

0V Collective Terminal Single-channel design maximum total current 40 A



Dimensions

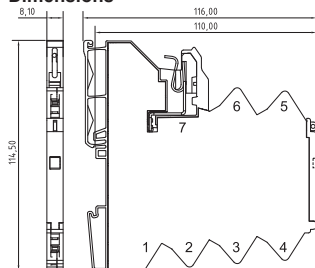

PIN assignment

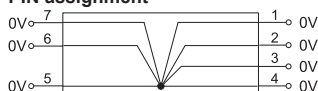

Description	Part-No.	Type	PU	
Nominal voltage	DC 12 / 24 V	716420	LOCC-Box-SK 7-6420	2
Input		LOCC-Box-SK 7-6420		
Nominal voltage	DC 12 / 24 V			
Rated current	6 × max. DC 10 A			
Reverse voltage protection	No			
Termination	Spring terminal: 0.25–2.5 mm ²			
Connection	1 – 6			
Output				
Output current	max. DC 40 A			
Voltage drop	–			
Termination	screwless disconnect terminal			
Connection	7			
General				
Housing material	PA 6.6 (UL 94-V0; NFF I2, F2)			
Field installation	rail TS 35 (EN 60175)			
Protection class	IP 20			
Installation position	Optional			
Operation temperature range	–25 °C – 60 °C			
Storage temperature range	–40 – 85 °C			
Dimensions (w × h × d) in mm	8.1 × 114.5 × 116.0			
Weight (kg/piece)	0.700			
Approvals	–			
Standards	–			

Load monitoring · Accessories

LOCC Box supply terminal LOCC Box supply terminal for power distribution maximum total current 40 A



Dimensions
Supply terminal

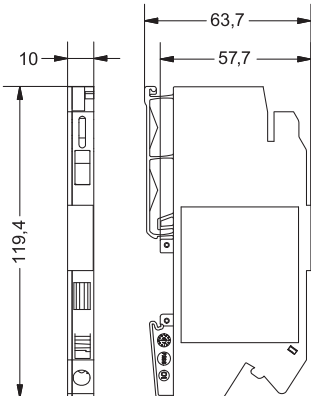
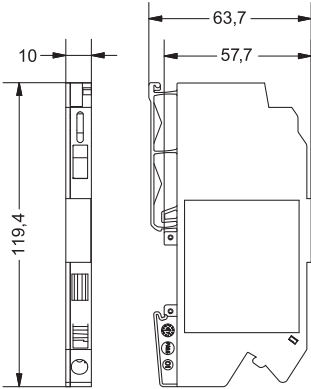

Description	Part-No.	Type	PU	
Nominal voltage	DC 12 / 24 V	716437	LOCC-Box-ES 7-6437	1
Input				
LOCC-Box-ES 7-6437				
Nominal voltage	DC 12 / 24 V			
Rated current	max. DC 40 A			
Reverse voltage protection	No			
Termination	Spring terminal : 0.33 – 10 mm ² (AWG 22–8) conductor connection cross section, single wire (solid): max. 10 mm ² conductor connection cross section, fine wire: max. 6 mm ² conductor connection cross section, fine wire with AEH: max. 6 mm ²			
Length of stripped insulation	12 mm			
Output				
Nominal voltage	DC 12 / 24 V			
Output current	max. DC 40 A			
Termination	screwless disconnect terminal			
Copper bus bar	3 × 10mm			
General				
Housing material	PA 6.6 (UL 94-V0; NFF I2, F2)			
Field installation	rail TS 35 (EN 60175)			
Protection class	IP 20			
Installation position	Optional			
Operation temperature range	-25 °C – 60 °C			
Storage temperature range	-40 – 85 °C			
Dimensions (w × h × d) in mm	10.0 × 119.4 × 63.7			
Weight (kg/piece)	0.035			
Approvals	cULus			
Standards	–			

LOCC-Pads • Monitoring software

LOCC-Pads*

Software for the parameterisation of the LOCC-Box-Net, as well as the analysis and diagnosis of DC 12 / 24 V circuits

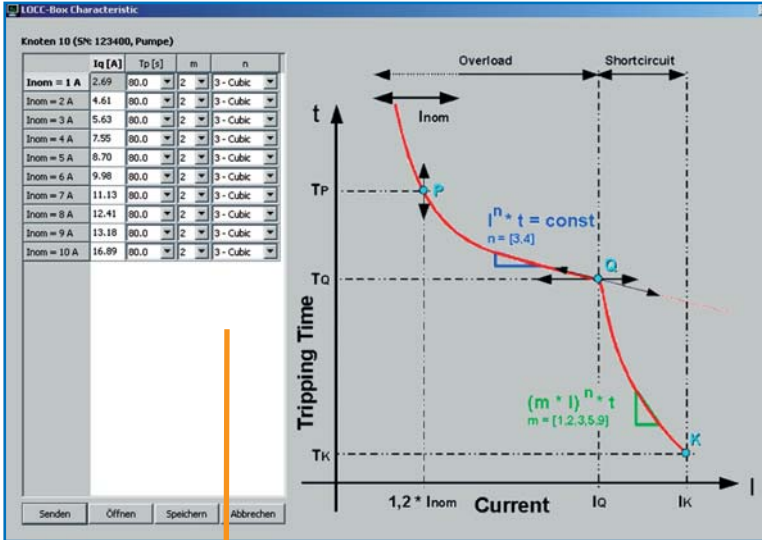

Adjustment parameters for the parameterisable characteristic No. 10



Displays the operating status, current range / characteristic, the load capacity of the characteristic, as well as the updated current and voltage values.

- COM Einstellung
- LOCC-Box Charakteristik
- LOCC-Box Module
- LOCC-Box Aufzeichnung
- LOCC-Box Einstellung
- LOCC-Box Gateway
- Firmware Download
- Sprache

Menu "Extra"

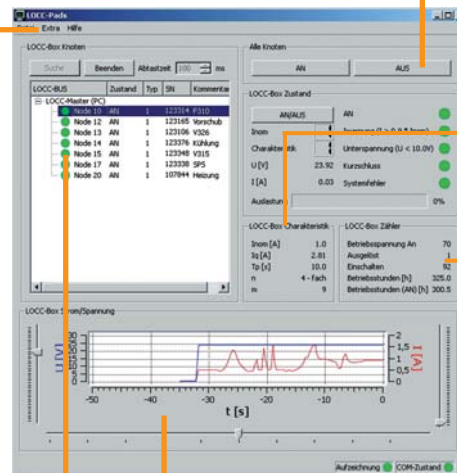

Overall view

Inom [A]	1.0
Iq [A]	2.81
Tp [s]	10.0
n	4 - fach
m	9

Displays the parameters of the selected characteristic curve.

Datum/Zeit	Knoten	Zustand	Fehler	I [A]	U [V]	Kommentar
2008-12-09 11:23:42						Aufzeichnung gestartet ...
2008-12-09 11:23:43	17	AN		0.06	23.92	SPS
2008-12-09 11:23:43	10	AN		0.06	23.61	Pumpe
2008-12-09 11:23:44	11	AN		0.03	23.92	L
2008-12-09 11:23:44	12	AN		0.06	23.77	Motor 1
2008-12-09 11:23:44	13	AN		0.06	23.46	V326
2008-12-09 11:23:45	14	AN		0.03	24.22	L
2008-12-09 11:23:45	15	AN		0.03	23.92	V315
2008-12-09 11:24:01	10	Ausgelöst	Kurzschluss	0.06	23.61	Pumpe
2008-12-09 11:24:07	10	AUS	Kurzschluss	0.00	0.00	Pumpe
2008-12-09 11:24:09	10	AN		0.06	23.61	Pumpe

Recording of all results such as "ON", "OFF" or "SHORT CIRCUIT" with date and time

Betriebsspannung An	42
Ausgelöst	39
Einschalten	142
Betriebsstunden [h]	144.0
Betriebsstunden (AN) [h]	108.5

Indicates the current meter readings of the selected module

LOCC-BUS	Zustand	Typ	SN	Kommentar
LOCC-Master (PC)				
Node 10	AN	1	123400	Pumpe
Node 11	AN	1	123314	L
Node 12	AN	1	123165	Motor 1
Node 13	AN	1	123106	V326
Node 14	AN	1	123376	L
Node 15	AN	1	123348	V315
Node 17	AN	1	123338	SPS

Overview of all connected modules

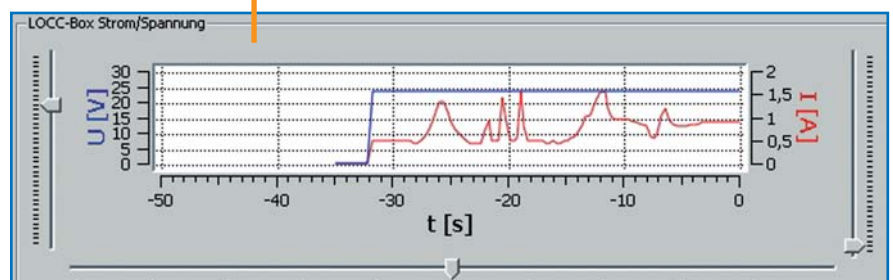

Plotter function for the selected module – current/voltage progression (analysis)

* in connection with a gateway (CANopen, EtherCAT, Profinet-IO, Profibus-DP)

Load monitoring · LCOS-CC

Electronic load monitoring up to DC 10 A

2-channel version, one-pole switching, DC 1 A – DC 10 A, characteristic can be set

Collective fault message: single/collective/90% message, Remote Control input



Dimensions

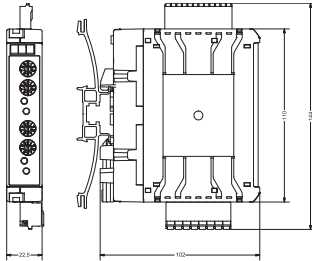

PIN assignment

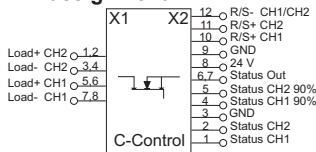

Description	Part-No.	Type	PU	
Screw terminal				
Nominal voltage	DC 24 V	779000.2111	LCOS-CC-2K-1P DC 24V	1
Push-In				
Nominal voltage	DC 24 V	779100.2111	LCOS-CC-2K-1P DC 24V	1
Note				
Included in the delivery	Plug-in terminals : RM5.08 and RM 3.50			
Not included in the delivery	Function carrier and other accessories, see „accessories“			
Input				
Nominal voltage	DC 24 V			
Operation voltage range	DC 20.4 V – 28.8 V			
Rated current	DC 10 A			
Supply current	DC 32 A via LCOS power bus			
Reverse voltage protection	internal electronics			
Control input (Set / Reset)				
Signal level	DC 24 V (EN 61131)			
OFF	Pulse with falling edge >100 ms, <800 ms			
ON	Pulse with falling edge > 1 s			
Galvanic insulation I/O	2.5 kV, 50 Hz, 1 min.			
Output				
Switching element	MosFet			
Output current	max. DC 10 A			
Voltage drop	<170 mV (10 A)			
Status Indication	LED green: operating voltage ON, no fault, green flashing: 90 % I _B red flashing: triggered, red: OFF			
Switch-on capacity	>10000 µF			
Current range	1 A – 10 A (adjustable via switch in 1 A steps)			
Characteristic	fast (1), middle (2), slow 1 (3), slow 2 (4), slow 3 (5), adjustable via switch, see 'characteristic curves'			
Signal output				
Switching element	Transistor in open collector version with Pull Up resistance			
Single channel message	(Status CH1, CH2) Acc. to IEC 61131-2: High level, no errors, low level, there are errors			
90 % of the rated current I _B	(Status 90 % CH1, CH2) Acc. to IEC 61131-2: High level <90 %, low level >90 %			
Insulation voltage	-			
centralised fault signalling	(Status Out) Single channel message 1+2, decoupled via diodes			
General				
Housing material	PA 6.6 (UL 94-V0; NFF I2, F2)			
Field installation	can be connected to LCOS function carrier 22.5 mm (accessories), DIN Rail mounting EN 60715			
Protection class	IP 20			
Installation position	Optional			
Vibration resistance	Vibration: EN 60068-2-6 Fc, Shock: EN 60068-2-27 Ea			
Climatic conditions	Acc. to EN 60721 Stationary use at weather protected locations			
Termination	X1: Load side: 8-pole measuring strip, CS 5,08 X2: Control side: 12-pole measuring strip, CS 3,5			
Operation temperature range	0 °C – 55 °C			
Storage temperature range	-40 – 70 °C			
Dimensions (w × h × d)	22.5 × 110.0 × 102.0 mm (including function carrier, without plug-in terminals on the side)			
Weight (kg/piece)	0.200			
Approvals	CE, UL601010UL2367			
Standards	EN 61131-2, EN 55016-1-2, EN 60529, EN 61000-6-2, EN 61000-6-4			

Load monitoring · LCOS-CC

Electronic load monitoring up to DC 10 A

1-channel version, two-pole switching, DC 1 A – DC 10 A can be set, characteristic can be set

Collective fault message: single/collective/90% message, Remote Control input per channel



Dimensions

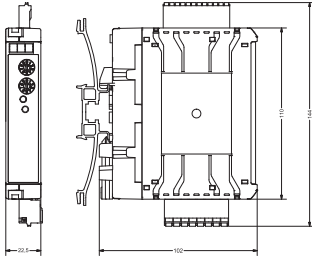

PIN assignment

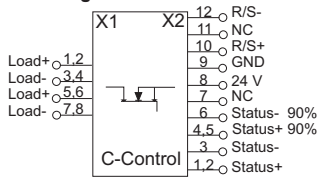

Description	Part-No.	Type	PU	
Screw terminal				
Nominal voltage	DC 24 V	779000.1211	LCOS-CC-1K-2P DC 24V	1
Push-In				
Nominal voltage	DC 24 V	779100.1211	LCOS-CC-1K-2P DC 24V	1
Note				
Included in the delivery	Plug-in terminals : RM5.08 and RM 3.50			
Not included in the delivery	Function carrier and other accessories, see „accessories“			
Input				
Nominal voltage	DC 24 V			
Operation voltage range	DC 20.4 – 28.8 V			
Rated current	DC 10 A			
Supply current	DC 32 A via LCOS power bus			
Reverse voltage protection	internal electronics			
Control input (Set / Reset)				
Signal level	DC 24 V (EN 61131)			
OFF	Pulse with falling edge >100 ms, <800 ms			
ON	Pulse with falling edge > 1 s			
Galvanic insulation I/O	2.5 kV, 50 Hz, 1 min.			
Output				
Switching element	MosFet and relay (galvanic separation both poles: 500 V)			
Output current	max. DC 10 A			
Voltage drop	<170 mV (10 A)			
Status Indication	LED green: operating voltage ON, no fault, green flashing: 90 % I _B red flashing: triggered, red: OFF			
Switch-on capacity	>10000 µF			
Current range	1 A – 10 A (adjustable via switch in 1 A steps)			
Characteristic	fast (1), middle (2), slow 1 (3), slow 2 (4), slow 3 (5), adjustable via switch, see 'characteristic curves'			
Signal output				
Switching element	One relay with 1 S per signal type			
Single channel message	(Status CH1, CH2) 1 N/O contact, AC/DC 250 V, 1 A Relay closed: error Relay open: no error			
90 % of the rated current I _B	(Status 90 % CH1, CH2) 1 N/O contact, AC/DC 250 V, 1 A Relay closed: >90 %, Relay open: <90 %			
Insulation voltage	2.5 kV, 50 Hz, 1 min.			
centralised fault signalling	-			
General				
Housing material	PA 6.6 (UL 94-V0; NFF I2, F2)			
Field installation	can be connected to LCOS function carrier 22.5 mm (accessories), DIN Rail mounting EN 60715			
Protection class	IP 20			
Installation position	Optional			
Vibration resistance	Vibration: EN 60068-2-6 Fc, Shock: EN 60068-2-27 Ea			
Climatic conditions	Acc. to EN 60721 Stationary use at weather protected locations			
Termination	X1: Load side: 8-pole measuring strip, CS 5,08 X2: Control side: 12-pole measuring strip, CS 3,5			
Operation temperature range	0 °C – 55 °C			
Storage temperature range	-40 – 70 °C			
Dimensions (w × h × d)	22.5 × 110.0 × 102.0 mm (including function carrier, without plug-in terminals on the side)			
Weight (kg/piece)	0.200			
Approvals	CE, UL601010UL2367			
Standards	EN 61131-2, EN 55016-1-2, EN 60529, EN 61000-6-2, EN 61000-6-4			

Modular housing system · LCOS Accessories

Construction width without supply: 22,5 mm
 Data bus 12-pole power bus AC/DC 500 V, 4×16 A
 Integrated PE contact

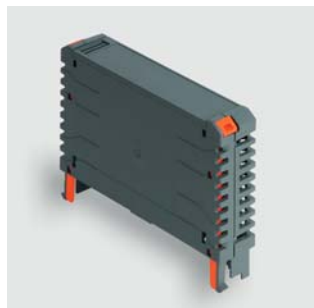

Description	Part-No.	Type	PU
Description	780100.225.1	LCOS-FGO-225-00/00/00-1	1
Function housing 22.5 mm, with cooling slits, closed front plate, no connection opening top/bottom	780100.225.2	LCOS-FGO-225-00/00/00-1	10
Function housing 22.5 mm, with cooling slits, closed front plate, connection opening top/bottom	780103.225.1	LCOS-FGO-225-01/00/01-1	1
Function housing 22.5 mm, with cooling slits, closed front plate, connection opening top/bottom	780103.225.2	LCOS-FGO-225-01/00/01-1	10
Function carrier 22.5 mm, cannot be expanded with modules, no PE direct contact	780200.225.1	LCOS-FT-NC-225-00-00-1	1
Function carrier 22.5 mm, cannot be expanded with modules, no PE direct contact	780200.225.2	LCOS-FT-NC-225-00-00-1	10
Function carrier 22.5 mm, cannot be expanded with modules, with PE direct contact	780201.225.1	LCOS-FT-PE-225-00-00-1	1
Function carrier 22.5 mm, cannot be expanded with modules, with PE direct contact	780201.225.2	LCOS-FT-PE-225-00-00-1	10
Function carrier 22.5 mm, can be expanded with modules, with PE direct contact	780331.225.1	LCOS-FT-PE-225-00-03-1	1
Function carrier 22.5 mm, can be expanded with modules, with PE direct contact	780331.225.2	LCOS-FT-PE-225-00-03-1	10
Function carrier 22.5 mm, can be expanded with modules, with PE direct contact, power module	780402.225.1	LCOS-FT-PE-225-0P-02-1	1
Function carrier 22.5 mm, can be expanded with modules, with PE direct contact, power module	780402.225.2	LCOS-FT-PE-225-0P-02-1	10
Function carrier 22.5 mm, can be expanded with modules, with PE direct contact, data and power module	780403.225.1	LCOS-FT-PE-225-DP-03-1	1
Function carrier 22.5 mm, can be expanded with modules, with PE direct contact, data and power module	780403.225.2	LCOS-FT-PE-225-DP-03-1	10

Modular housing system - LCOS Accessories

Construction width without supply: 35 mm
 Data bus 12-pole power bus AC/DC 500 V, 4×16 A
 Integrated PE contact



Description	Part-No.	Type	PU
Function housing 35 mm, with cooling slits, closed front plate, no connection opening top/bottom	780100.350.1	LCOS-FGO-350-00/00/00-1	1
Function housing 35 mm, with cooling slits, closed front plate, no connection opening top/bottom	780100.350.2	LCOS-FGO-350-00/00/00-1	10
Function housing 35 mm, with cooling slits, closed front plate, connection opening top/bottom	780103.350.1	LCOS-FGO-350-01/00/01-1	1
Function housing 35 mm, with cooling slits, closed front plate, connection opening top/bottom	780103.350.2	LCOS-FGO-350-01/00/01-1	10
Function carrier 35 mm, cannot be expanded with modules, no PE direct contact	780200.350.1	LCOS-FT-NC-350-00-00-1	1
Function carrier 35 mm, cannot be expanded with modules, no PE direct contact	780200.350.2	LCOS-FT-NC-350-00-00-1	10
Function carrier 35 mm, cannot be expanded with modules, no PE direct contact	780201.350.1	LCOS-FT-PE-350-00-00-1	1
Function carrier 35 mm, cannot be expanded with modules, no PE direct contact	780201.350.2	LCOS-FT-PE-350-00-00-1	10
Function carrier 35 mm, can be expanded with modules, with PE direct contact	780331.350.1	LCOS-FT-PE-350-00-03-1	1
Function carrier 35 mm, can be expanded with modules, with PE direct contact	780331.350.2	LCOS-FT-PE-350-00-03-1	10
Function carrier 35 mm, can be expanded with modules, with PE direct contact, power module	780402.350.1	LCOS-FT-PE-350-0P-02-1	1
Function carrier 35 mm, can be expanded with modules, with PE direct contact, power module	780402.350.2	LCOS-FT-PE-350-0P-02-1	10
Function carrier 35 mm, can be expanded with modules, with PE direct contact, data and power module	780403.350.1	LCOS-FT-PE-350-DP-03-1	1
Function carrier 35 mm, can be expanded with modules, with PE direct contact, data and power module	780403.350.2	LCOS-FT-PE-350-DP-03-1	10

Modular housing system · LCOS Accessories

Construction width with supply: 57,5 mm, 70 mm

Data bus 12-pole power bus AC/DC 500 V, 4×16 A

Integrated PE contact



Description	Part-No.	Type	PU
Function carrier 57.5 mm, with supply DC 24 V, no FBS, with PE direct contact, ready for connection	780700.575.1	LCOS-FTE-PE-575-NC-00-1	1
Function carrier 70 mm, with supply DC 24 V, no FBS, with PE direct contact, ready for connection	780700.700.1	LCOS-FTE-PE-700-NC-00-1	1
Function carrier 57.5 mm, with supply AC 240 V, no FBS, with PE direct contact, ready for connection	780701.575.1	LCOS-FTE-PE-575-NC-01-1	1
Function carrier 70 mm, with supply AC 240 V, no FBS, with PE direct contact, ready for connection	780701.700.1	LCOS-FTE-PE-700-NC-01-1	1
Function carrier 57.5 mm, with supply 3-phase AC 500 V, no FBS, with PE direct contact, ready for connection	780702.575.1	LCOS-FTE-PE-575-NC-02-1	1
Function carrier 70 mm, with supply 3-phase AC 500 V, no FBS, with PE direct contact, ready for connection	780702.700.1	LCOS-FTE-PE-700-NC-02-1	1

Modular housing system - LCOS Accessories

Accessories

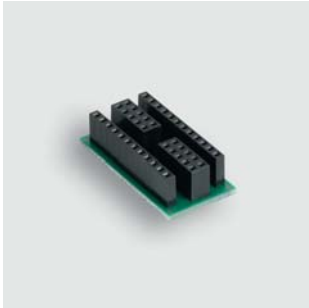

Description	Part-No.	Type	PU
Replace front plate, closed, function housing 22.5 mm	780600.225.3	LCOS-ZB-FPL-225-00-1	50
Replace front plate, closed, function housing 22.5 mm	780600.225.4	LCOS-ZB-FPL-225-00-1	100
Replace front plate, closed, function housing 35 mm	780600.350.3	LCOS-ZB-FPL-350-00-1	50
Replace front plate, closed, function housing 35 mm	780600.350.4	LCOS-ZB-FPL-350-00-1	100
Data module 22.5 mm	780900.225.2	LCOS-ZB-DM-225-12-00-1	10
Data module 22.5 mm	780900.225.3	LCOS-ZB-DM-225-12-00-1	50
Data module 35 mm	780900.350.2	LCOS-ZB-DM-350-12-00-1	10
Data module 35 mm	780900.350.3	LCOS-ZB-DM-350-12-00-1	50
Power module 22.5 mm	780910.225.2	LCOS-ZB-PM-225-00-1	10
Power module 22.5 mm	780910.225.3	LCOS-ZB-PM-225-00-1	50
Power module 35 mm	780910.350.2	LCOS-ZB-PM-350-00-1	10
Power module 35 mm	780910.350.3	LCOS-ZB-PM-350-00-1	50
Attachment screws data/power module	780991.000.4	LCOS-ZB-Schraube-00	100
Coding pins	780990.000.3	LCOS-ZB-Codier	50
Data bridge 12-pole, insulated	780960.012.2	LCOS-ZB-DB-12-00	10
Data bridge 12-pole, insulated	780960.012.3	LCOS-ZB-DB-12-00	50
Power bridge 1-pole, insulated	780961.001.2	LCOS-ZB-PB	10
Power bridge 1-pole, insulated	780961.001.3	LCOS-ZB-PB	50
PCB contact Power and PE, 10 A, 1-pole	780962.000.4	LCOS-ZB-LPK-00	100
PCB contact Power and PE, 10 A, 1-pole	780962.000.5	LCOS-ZB-LPK-00	500
PCB contact Power and PE, 10 A, 1-pole	780962.000.6	LCOS-ZB-LPK-00	1000
Labelling plates 5x5 mm, white, frame with 200 plates	780981.000.2	LCOS-ZB-BZS-white-00	10
Labelling plates 5x5 mm, red, frame with 200 plates	780982.000.2	LCOS-ZB-BZS-red-00	10
Labelling plates 5x5 mm, blue, frame with 200 plates	780983.000.2	LCOS-ZB-BZS-blue-00	10
Terminal black, CS 5.08, 8-pole, 2.5 mm ² Push-in, 1-8 printed	780922.000.2	LCOS-ZB_KL_FS-508-25-8-black	10
Terminal black, CS 3.50, 12-pole, 1.5 mm ² Push-in, 1-12 printed	780921.000.2	LCOS-ZB-KL_FS-350-15-12-black	10
Laboratory printed circuit board (PCB) FR4, 1.5 mm	780963.000.2	LCOS-ZB-EB-00-L	10

LCOS-CC • Characteristic Curves

All device variants incorporate the same characteristics

1-10 A (6A)

Switch position 1: Characteristic fast

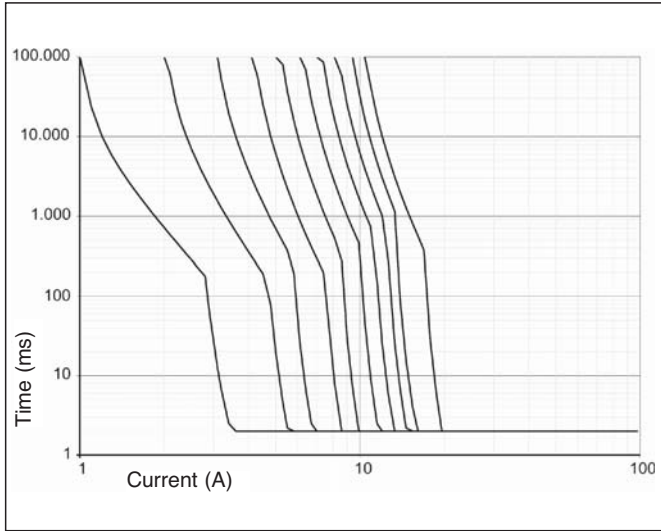

Switch position 2: Characteristic medium

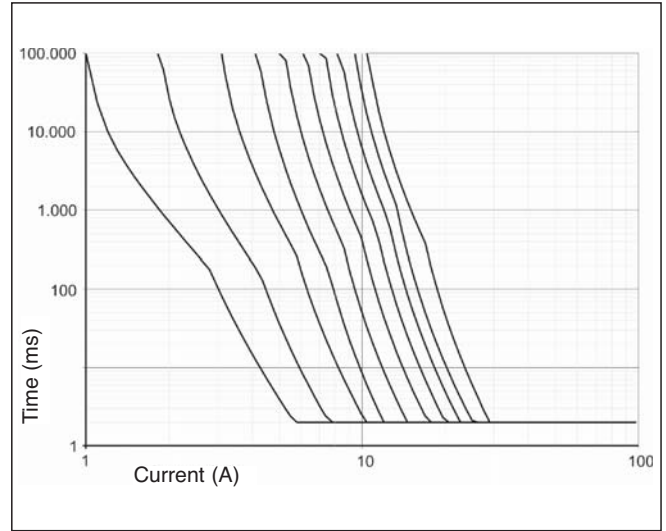

Switch position 3: Characteristic slow-1

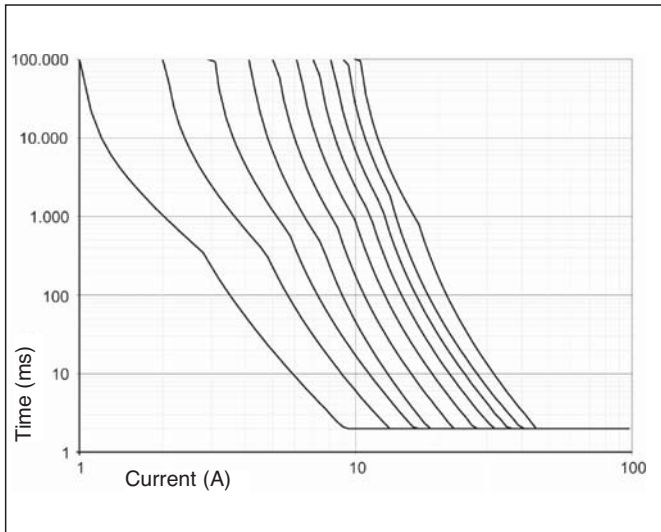

Switch position 4: Characteristic slow-2

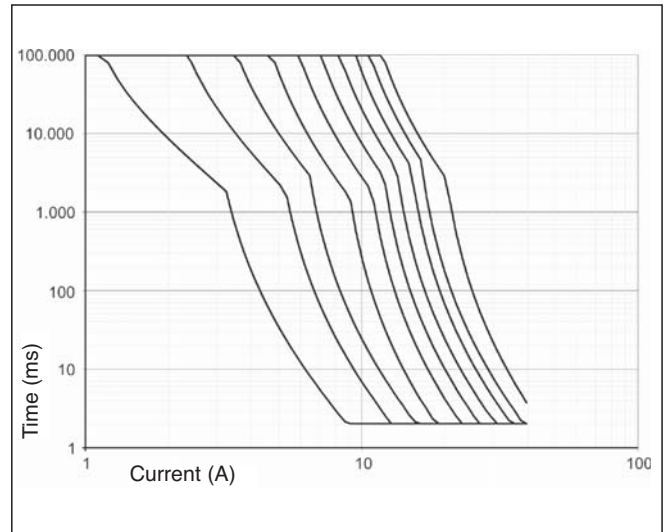

Switch position 5: Characteristic slow-3

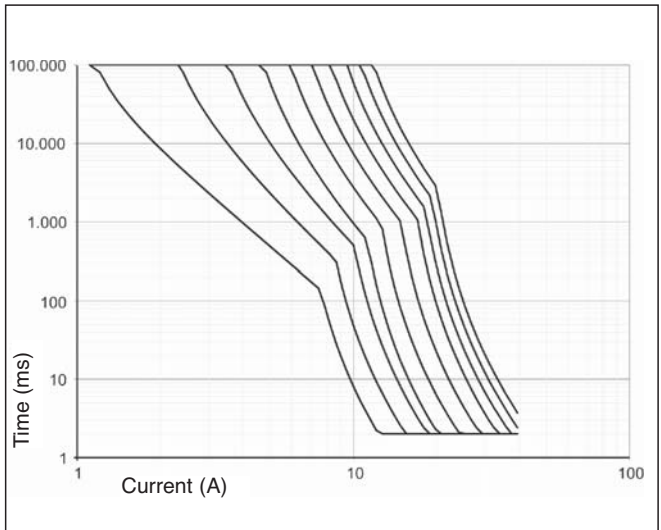

LCOS-CC • Characteristic Curves

Characteristic Curves 0-2 A

Switch position 1: Characteristic fast

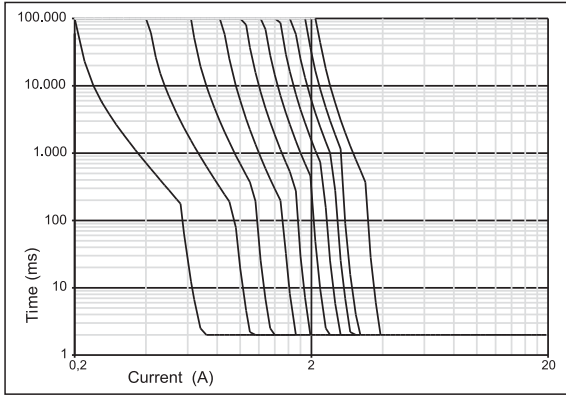

Switch position 2: Characteristic medium

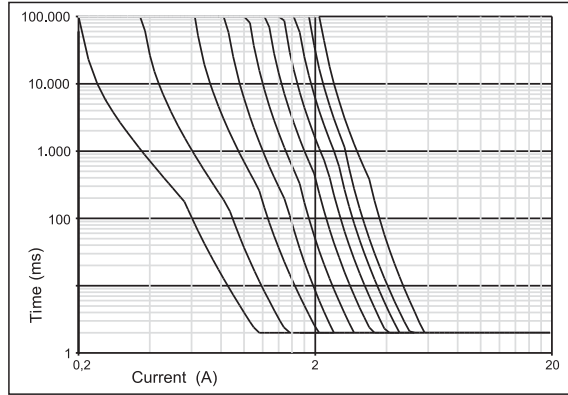

Switch position 3: Characteristic slow

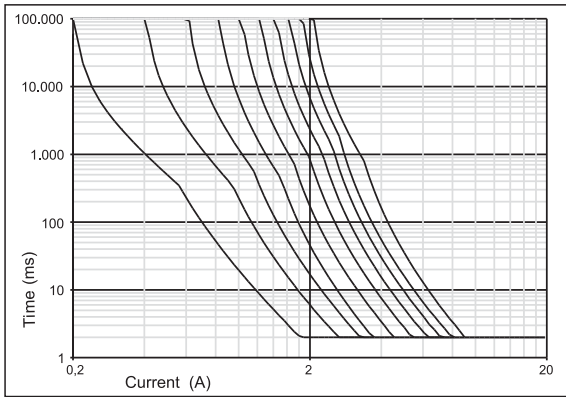

Characteristic Curves NEC Class 2

Switch position 1: Characteristic fast

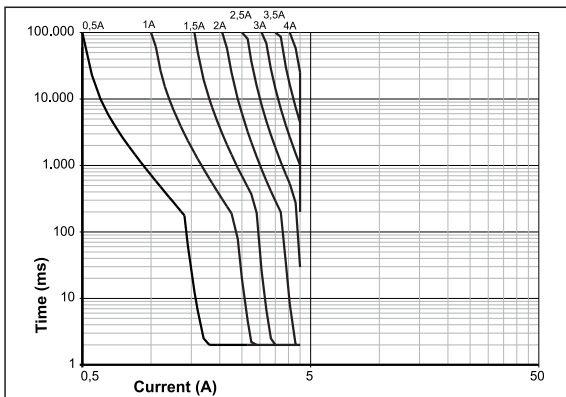

Switch position 2: Characteristic medium

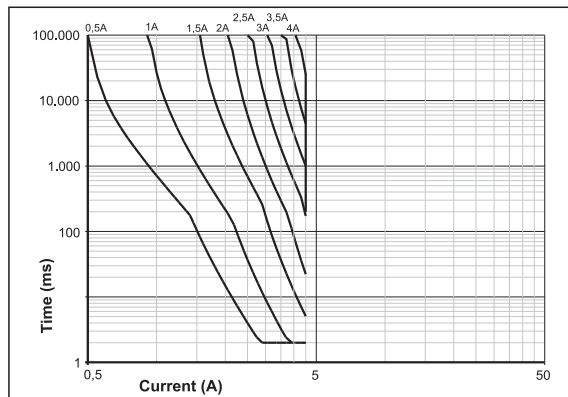

Switch position 3: Characteristic slow

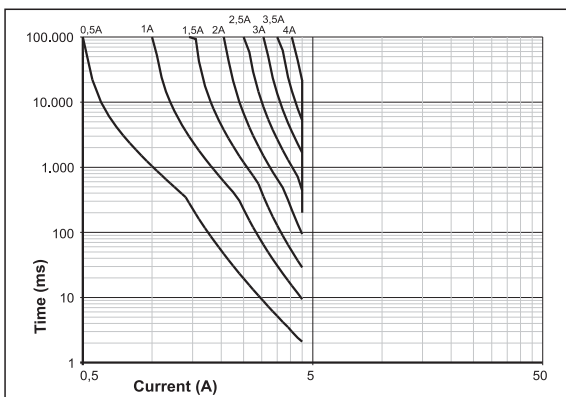

Load monitoring - Varioprint fuse module

AC/DC Load monitoring with fuse (5 × 20 mm)

Monitoring circuits 2.5 A und 6.3 A

Group signal using potential-free relay contact (only 716123)



Dimensions

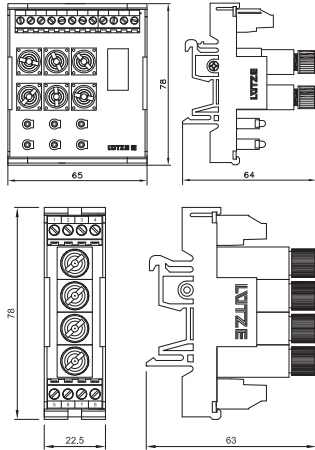

PIN assignment

716123

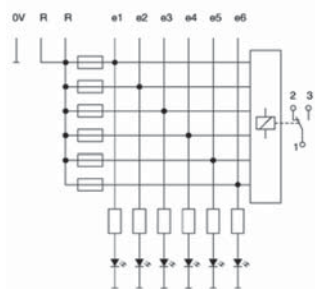

710820

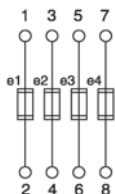

Description	Part-No.	Type	PU
Load monitoring 6×2.5 A			
Termination	716123	SIPE-6LED-6123	1
Load monitoring 4×6.3 A			
Termination	710820	SIPE-4/E 250V	2
Input			
	716123	710820	
Nominal voltage	DC 24 V	AC/DC 230 V	
Input voltage range	16.8 – 30.0 V	0.0 – 250.0 V	
Rated current	6 × DC 2.5 A	4 × DC 6.3 A	
Fuse	Glass tube 5x20 mm, not included in delivery		
Resistor	<0.1 Ω		
Status Indication	–		
Rated insulation voltage (EN 50178)	150 V	300 V	
Pollution degree	2		
Overvoltage category	I		
Signal circuit			
Switching element	Relay		
Contact type	1 change over contact		
Min. switching voltage	AC/DC 17 V		
Max. switching voltage	AC/DC 250 V		
Min. switching current	AC/DC 0.10 mA		
Max. switching current	AC/DC 3 A		
Switch-on delay	8 ms		
Switch-off delay	8 ms		
Switching capacity	max. 1250 VA		
Contact material	AgNi		
Mechanical service life	2 × 10 ⁷ operations		
Rated insulation voltage (EN 40178)	250 V		
Clearance/creep. dist. (control/load side)	>2 mm		
General			
Form	Varioprint		
Protection class	IP 20		
Field installation	rail TS 35 (EN 50022)		
Insulation voltage input/output	–		
Safe isolation	–		
Operation temperature range	-20 – + 60 °C		
Storage temperature range	-25 – 80 °C		
Dimensions (w × h × d)	65.0 × 77.0 × 63.0 mm	22.5 × 77.0 × 63.0 mm	
Weight (kg/piece)	0.116	0.070	
Approvals	–		
Termination	Screw terminal: 0.25–2.5 mm ²		

Accessories	Article number	Description	PU
Identification unit	710799		100

Power supply · DC/DC converter

DC/DC converter, 1-channel

Input: DC 24 V

Output: DC 24 V / 10 V / 9 V / 5 V



Dimensions

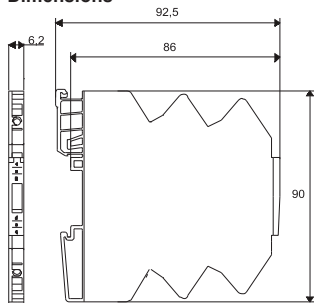

PIN assignment

762185/762186

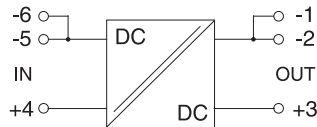

762184/762084, 762187/762188

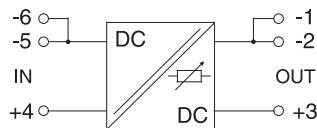

Description	Part-No.	Type	PU	
Screw terminal				
Output voltage/current	DC 24 V, 30 mA	762185	CV 7-2185 DC24V/24V	1
	DC 10 V, 100 mA	762184	CV 7-2184 DC24V/10V	1
	DC 5 V, 150 mA	762187	CV 7-2187 DC24V/5/9	1
Spring terminal				
Output voltage/current	DC 24 V, 30 mA	762186	CV 7-2186 DC24V/24V	1
	DC 10 V, 100 mA	762084	CV 7-2084 DC24V/10V	1
	DC 5 V, 150 mA	762188	CV 7-2188 DC24V/5/9	1

Input	762185/762186	762184/762084	762187/762188
Nominal voltage	DC 24 V		
Operation voltage range	DC 16.8–30 V		
Rated current	21.5 mA	14 mA	15 mA
Inrush current	–		
Internal fuse	–		
External fuse	–		
Power Factor Correction P.F.C.	–		
Status Indication	– LED		
Short-circuit current	<250 mA		
Output	DC 24 V	DC 10 V	DC 5 V / 9 V
Rated voltage output	DC 24 V	DC 10 V	DC 5 V / 9 V
Rated current output	30 mA	100 mA	100 mA / 100 mA
Configuration	– via DIP switch (see instruction leaflet)		
Max. output current	–		
Short-circuit current	<900 mA		
Voltage trim range	–	±1.0 V via potentiometer	±0.5 V / ±1.0 V via potentiometer

Load regulation	<1 %		
Rise time	<20 ms	<10 ms	
Ripple & Noise	<20 mV _{eff}	<10 mV _{eff}	
Temperature coefficient	–		
Hold up time	–		
Parallel/redundant operation	No		
Low power loss	–		
Over voltage protection	–		
Overtemperature protection	–		
Short circuit characteristics	Current limit		

General			
Insulation voltage input/output	1.5 kV _{eff}	0.5 kV _{eff}	1.5kV _{eff}
Rated insulation voltage (EN 50178)	50 V		
Derating	–		
Operation temperature range	–25 °C – 60 °C		
Storage temperature range	–40 °C – 85 °C		
M.T.B.F.	–		
Dimensions (w × h × d)	6.2 × 90.0 × 92.5 mm		
Cooling	Air convection		
Housing material	PA		
Field installation	can be snapped onto top-hat rail TS 35 (EN 60715)		
Application height	–		
Installation position	Optional		
Protection class	IP 20 (IEC 529, EN 60529)		
IP rating	–		
Overvoltage category	I		
Pollution degree	2		
Weight (kg/piece)	0.040		
Termination	Screw terminal: 0.14–1.5 mm ²		

Approvals	–						
Accessories	Color	2-pole	3-pole	4-pole	8-pole	16-pole	PU
6 A jumper comb	red	762802	762805	762812	762822	762832	10
6 A jumper comb	white	762803	762806	762813	762823	762833	10
6 A jumper comb	blue	762804	762807	762814	762824	762834	10

Accessories	Color	Article number	Type	PU
Tag holder 4×11 mm	white	681313	BZT-0411	100
Isolation plate		760809	TP 7-0809	10
Labels for laser printer A4 unpunched		681031	LEB-A4	1

Article number index

Part-No.	Page	Part-No.	Page	Part-No.	Page	Part-No.	Page	Part-No.	Page	Part-No.	Page
710820	96	722805	38	780331.350.2	91						
716123	96	722806	39	780402.225.1	90						
716400	64	722807	51	780402.225.2	90						
716401	64	722808	36	780402.350.1	91						
716401.0050	64	722809	38	780402.350.2	91						
716403	71	722810	39	780403.225.1	90						
716404	71	722811	52	780403.225.2	90						
716406	66	722812	52	780403.350.1	91						
716407.xxxx	67	722813	52	780403.350.2	91						
716408	69	722814	54	780600.225.3	93						
716409	65	722815	50	780600.225.4	93						
716410	72	722816	54	780600.350.3	93						
716410.0050	72	722986	48	780600.350.4	93						
716411	73	722987	40	780700.575.1	92						
716412.xxxx	68	722989	48	780700.700.1	92						
716413	70	722995	45	780701.575.1	92						
716414	75	722996	47	780701.700.1	92						
716418	74	722999	53	780702.575.1	92						
716420	85	723100	57	780702.700.1	92						
716421	83	723110	56	780900.225.2	93						
716425	80	723115	59	780900.225.3	93						
716435	81	723120	58	780900.350.2	93						
716436	82	728753	27	780900.350.3	93						
716437	86	728754	29	780910.225.2	93						
716456	79	728758	32	780910.225.3	93						
716457	77	728761	22	780910.350.2	93						
716458	78	728762	24	780910.350.3	93						
716459	76	728763	27	780921.000.2	93						
722751	23	728764	28	780922.000.2	93						
722752	25	728766	22	780960.012.2	93						
722753	26	728768	27	780960.012.3	93						
722754	30	728769	29	780961.001.2	93						
722757	31	728775	27	780961.001.3	93						
722758	32	728776	29	780962.000.4	93						
722759	34	762084	97	780962.000.5	93						
722761	23	762184	97	780962.000.6	93						
722762	24	762185	97	780981.000.2	93						
722763	26	762186	97	780982.000.2	93						
722764	28	762187	97	780983.000.2	93						
722766	23	762188	97	780990.000.3	93						
722767	25	779000.1211	89	780991.000.4	93						
722768	26	779000.2111	88								
722769	30	779001.1413	19								
722770	32	779101.1413	19								
722773	23	779100.1211	89								
722774	25	779100.2111	88								
722775	26	780100.225.1	90								
722776	30	780100.225.2	90								
722777	32	780100.350.1	91								
722778	34	780100.350.2	91								
722779	37	780103.225.1	90								
722781	34	780103.225.2	90								
722781.1000	35	780103.350.1	91								
722782	37	780103.350.2	91								
722783	44	780200.225.1	90								
722784	44	780200.225.2	90								
722785	46	780200.350.1	91								
722786	46	780200.350.2	91								
722787	42	780201.225.1	90								
722789	43	780201.225.2	90								
722800	50	780201.350.1	91								
722801	49	780201.350.2	91								
722802	51	780331.225.1	90								
722803	33	780331.225.2	90								
722804		780331.350.1	91								

Copyright

Protected trademarks and trade names are not always labelled as such in this publication. This does not mean they are free names as defined in the trademark and brand mark law. Publication does not imply that the descriptions or pictures used are free from rights of third parties. The information is published without regard to possible patent protection. Trade names are used without any guarantee that they can be used freely. In putting together text, pictures and data, we proceeded with the greatest care. Despite this, the possibility of errors cannot be completely excluded. We therefore reject any legal responsibility or liability. We are, of course, grateful for any recommendations for improvement or information useful for making corrections or establishing the truth. But the author does not assume any responsibility for the content of these documents.



RoHS

Germany
 Friedrich Lütze GmbH
 Postfach 12 24 (PLZ 71366)
 Bruckwiesenstrasse 17-19
 D-71384 Weinstadt
 Tel.: +49 7151 6053-0
 Fax: +49 7151 6053-277(-288)
 info@luetze.de



- Cables**
- Cable assemblies**
- Cable fittings**
- LSC Wiring System**
- Module and Interface Technology**
- Ethernet Connectivity**
- Suppression Technology**
- Power Supplies**
- Railway Technology**

United Kingdom
 LÜTZE Ltd.
 Unit 3 Sandy Hill Park
 Sandy Way, Amington
 Tamworth, Staffs, B77 4DU
 Tel.: +44 1827 31333-0
 Fax: +44 1827 31333-2
 sales.gb@luetze.co.uk

USA
 LUTZE INC.
 13330 South Ridge Drive
 Charlotte, NC 28273
 Tel.: +1 704 504-0222
 Fax: +1 704 504-0223
 info@luetze.com

Austria
 LÜTZE Elektrotechnische
 Erzeugnisse Ges.m.b.H.
 office@luetze.at

Switzerland
 LÜTZE AG
 info@luetze.ch

France
 LUTZE SAS
 lutze@lutze.fr

Spain
 LUTZE, S.L.
 info@luetze.es

China
 Luetze Trading (Shanghai) Co.Ltd.
 info@luetze.cn

