

Linking your system



Flow sensors



EMA's electronic flow sensors operate in accordance with theory of thermo-diffusion that the sensors are using a physical principle, flowing mediums absorption and heat transportation. There are two thermistors and one heater in the probes. This heat cause an increase in temperature in certain areas, and the increased part is detected by one probe of them. As long as the mediums passes by, the probe can cool down which is again detected by the thermistors. Absorption rate are put into relation to a rate of flow which is indicated on the unit. Flow direction and position of sensor do not matter because the unit works without mechanical parts.

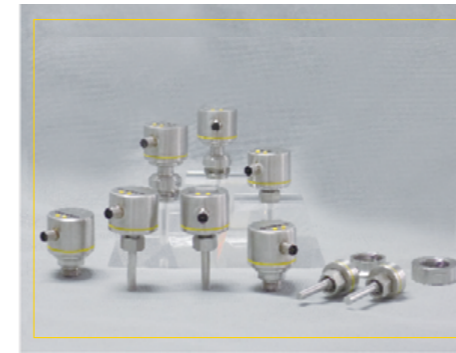

Features

FL series is an electronic device designed for monitoring a certain rate. Without mechanical components, this guarantees a reliable monitoring even in case of complex mediums over a long period. The purpose of FL series is to output a signal when the flow rate reaches the set-up range. Through control calculation, FL series can proceed to warn or activate the chain of protection system in order to protect the key equipments and to avoid unexpected damage in production. It can not only successfully reduce the possibility of breakdown and the cost of maintenance, but also keep the countless reliability of operational safety and of economic benefits. FL series is provide stable and steady service and are useable in hazardous areas by adapting to the theory of thermo-diffusion. It can be inserted into the tube or the container and set up the flow rate to an expected value. FL series is an electronic flow sensor meant for modern industry. It is applied widely in highly developed countries and has surpassed traditional flow switches.

Electric flow sensor is more stable and durable than traditional mechanical switch

Mechanical Flow Switches



✘ Detect the flow mediums by the swing amplitude of the mechanical paddles or probes.



✘ No matter of paddles or probes, the detection will be affected by the low sensitivity due to the rusty probes under a long-term operation.



✘ Serious rustiness even causes the break of paddles or probes, and then falling probes may clog up the pipes or damage the machines. It not only makes the mechanical flow switches operate falsely, but also face the derivative problems on the maintenance of pipe system and of machines.

Smart Flow Sensors



✔ Equipped with a mini probe, FL series does not effect the flow of mediums while detecting the flow rate.

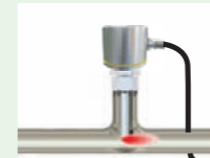

✔ The unit is also usable for applications with a slow rate of flow which causes a slow dissipation in temperature at the probe. On the contrary, fast rates of flow can also be detected very easily up to a maximum rate of flow.

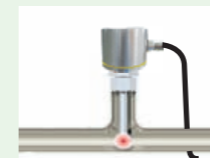

✔ Using stainless steel for the probe means no rust and more accurate readings.

Flow + Temperature Sensor

Flow + Temperature Sensor is the most progressive technique and is created exclusively to satisfy the demands of customers. It perfectly combines temperature sensor and flow sensor in one unit. The LED bar can display indication of the temperature and flow range as well as output warning signals separately. With features such as high precision, usage of very small space, user-friendly handling and impressive design it can be applied in all industries. Those deal with electricity, sewage disposal, petroleum, chemical engineering, metallurgy, glass, coolant system, machinery production and more.



- 1 Unique design in the world, programmable smart flow + temperature sensor
- 2 Users can set the range and switch point of flow rate and temperature through the buttons
- 3 Interactive visualization interface make it easier to monitor on-site
- 4 Built-in high precision sensor chip, widely used in detecting gas and liquid
- 5 Overload, short-circuit and reverse polarity power protection
- 6 Stainless steel housing

Installation

1. It is strongly suggested to install the sensor in the sides while installing it in the horizontal pipe.(Fig.1)
- It is supposed to clear up the sediments while installing the sensor in the bottom of the pipe.
- It is supposed to pay attention to the medium occupied the pipe while installing the sensor in the top of the pipe.
2. Please install the sensor in the place which the medium flows upward while installing it in the vertical pipe.(Fig.2)

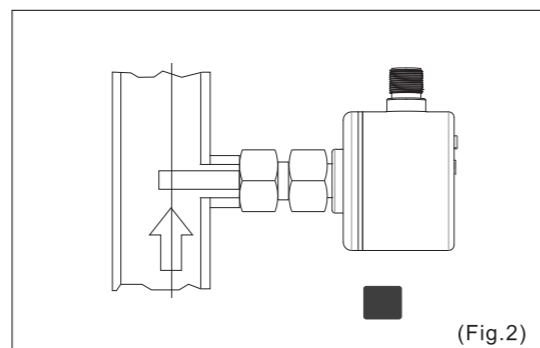
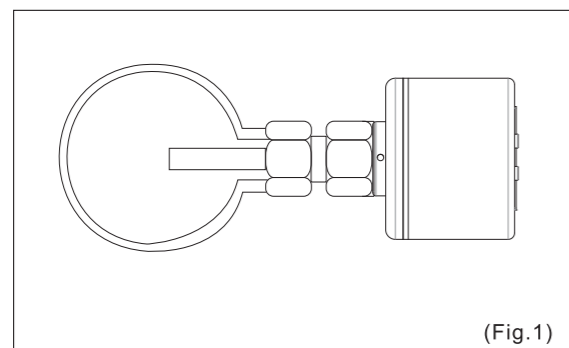

Avoiding damage, the user should watch out for the minimum distance between the sensor and the curve, the valve and the cross section which changes.(Fig.3):

- Entrance (A) min.5xD
- Exit (B) min.3xD
- Diameter of the pipeline(D)

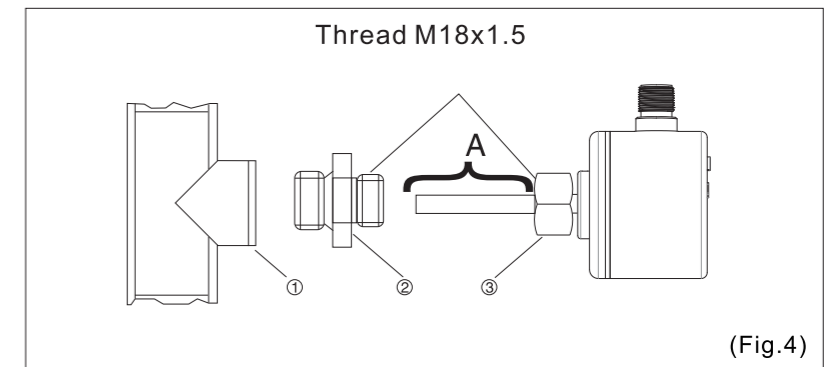
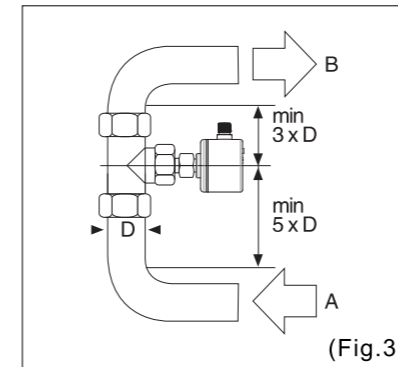

1. To screw the nut smoothly, please add the lubricant on the nut ③ and the threads. (Fig.4)
Notice: It is disallowed to add lubricant on the sensor probe(A).
2. Screw a suitable adapter ② to the joint ①. (Fig.4)
3. Insert the sensor to the adapter and then screw the nut ③ (The biggest screwing torque: 50Nm). (Fig.4)

The depth of insertion: The minimum depth inserting to the pipeline is 12mm. To insure the correct depth, the user can use an adapter ②(Accessory; optional order).
Notice: The probe of sensor is not allowed to contact the wall of the pipe.

Menu setting and indication status

Control panel

Potentiometer type

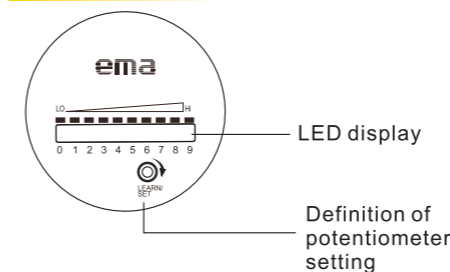

Definition of potentiometer setting

SP setting:
Rotate in clockwise direction, LED increase
Rotate in anticlockwise direction, LED decrease

Display function (Operation mode)

	Overflow flow (LED flashes)
	SP setting (LED 1 display)
	Current flow in display range (LED bar green)
	Exceed flow range (LED full display)

LED = Red LED = Green

Smart type

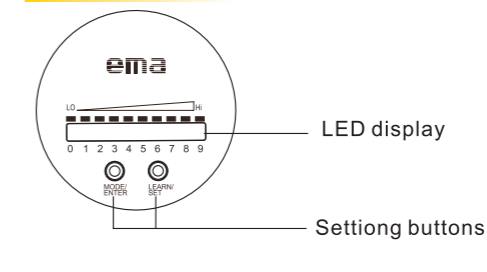

Button definition

MODE / ENTER: Selection / Confirmation
Learn/Set: Adjust to the biggest / smallest flow; value setting(Keep pressing button to scroll the display; Press button once to increase the value progressive.)

Display (Operation)

	In the display range (LED bar Green)
	Over the flow range (LED 9 Flash)
	Current is too low (LED 0 Flash)

Switching point display (SP) :
LED Orange: Flow>SP; LED Red: Flow<SP

Flow+Temp. type

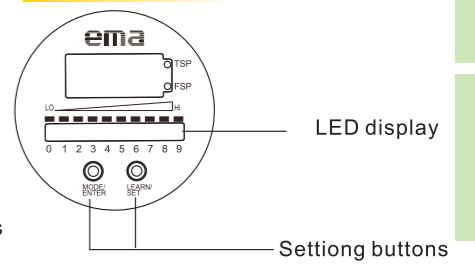

Button definition

MODE/ENTER: Selection / Confirmation
LEARN/SET: Adjust the setting rate of flow/value, the temperature SP (display, output, calibration of temperature, flow SP, and remote enable function.)

Display (Operation)

	In the display range (LED bar Green)
	Over the flow range (LED 9 Flash)
	Current is too low (LED 0 Flash)

Switching point display (SP) :
LED Orange: Flow>SP; LED Red: Flow<SP

Flow Sensors

Pressure Sensors

Temperature Sensors



- Programmable flow sensor. User can set the flow range and switch point via buttons easily
- Sensible substance: gas, liquids
- Power protection: overload, shortcircuit, reverse polarity
- Medium temperature: -25°C~80°C
- Robust housing/probe stainless steel 316L
- Protection: IP68



Accessories:

Type	Connector Order No.						Drawing No.
	C	02	I	5	C	12	I : E3U11
	C: Cable	Length 02: 2M 05: 5M 10: 10M	Connector I: Straight L: Angled	Pole 4: 4 5: 5	Material R: PUR C: PVC S: PVC Shielded wire	Size 12: M12	L : E3U12

Order No.	US0001	US0002	US0003	US0007	US0009	US0023
Type						
	M18 x 1.5 – M12 x 1	M18 x 1.5 – G1/4"	M18 x 1.5 – G1/2"	M18 x 1.5 – Ø24mm	M18 x 1.5 – M18 x 1.5	M18 x 1.5 – G1/4"
Drawing No.	E3U01	E3U02	E3U03	E3U07	E3U08	E3U09

* US0023 is used for low flow rate

Drawing

Page	>>> P. 50–53
------	--------------

Order NO.

FL60 Smart type

Order NO.	Thread Type	Thread	Sensible Range Liquid (cm/s)	Sensible Range gas (cm/s)	Output	Probe Length (mm)	Supply Voltage (V)	Drawing No.
FL6001	Internal	M18x1.5	3~300	200~3000	PNP NO/NC	45	20~36 DC	E3F01
FL6002	Internal	M18x1.5	3~300	200~3000	NPN NO/NC	45	20~36 DC	E3F01
FL6003	Internal	M18x1.5	3~300	200~3000	RELAY NO/NC	45	20~36 DC	E3F01
FL6004	Internal	M18x1.5	3~300	200~3000	RELAY NO/NC	45	85~265 AC	E3F01
FL6005	Internal	M18x1.5	3~60	200~800	4~20mA	45	20~36 DC	E3F01

FL60 Extra length probe

Order NO.	Thread Type	Thread	Sensible Range Liquid (cm/s)	Sensible Range gas (cm/s)	Output	Probe Length (mm)	Supply Voltage (V)	Drawing No.
FL6011	Internal	M18x1.5	3~300	200~3000	PNP NO/NC	100	20~36 DC	E3F01
FL6012	Internal	M18x1.5	3~300	200~3000	NPN NO/NC	100	20~36 DC	E3F01
FL6013	Internal	M18x1.5	3~300	200~3000	RELAY NO/NC	100	20~36 DC	E3F01
FL6014	Internal	M18x1.5	3~300	200~3000	RELAY NO/NC	100	85~265 AC	E3F01

FL61 Titanium alloy probe

Order NO.	Thread Type	Thread	Sensible Range Liquid (cm/s)	Sensible Range gas (cm/s)	Output	Probe Length (mm)	Supply Voltage (V)	Drawing No.
FL6101	Internal	M18x1.5	3~300	200~3000	PNP NO/NC	45	20~36 DC	E3F01
FL6102	Internal	M18x1.5	3~300	200~3000	NPN NO/NC	45	20~36 DC	E3F01
FL6103	Internal	M18x1.5	3~300	200~3000	RELAY NO/NC	45	20~36 DC	E3F01
FL6104	Internal	M18x1.5	3~300	200~3000	RELAY NO/NC	45	85~265 AC	E3F01

Technical parameters:

Housing/Probe material: Stainless steel 316L
 Connection: M12 Socket
 Pressure rating [bar]: 300
 Max. current load [mA]: 400
 Voltage drop [V]: < 2.5
 Power-on delay time [s]: < 8
 Output response time [s] : < 2
 4...20mA Output accuracy: ± 10%
 Medium temperature [°C]: -25...80



- Programmable smart flow + temperature sensor, user can set flow range and switch point via buttons easily
- Visual indication makes the control of this sensor easier
- Sensible substance: gas, liquids
- Power protection: overload, short-circuit, reverse polarity
- Medium temperature: -25°C~80°C
- Robust housing/probe stainless steel 316L
- Protection: IP68



Accessories:

Type	Connector Order No.						Drawing No.
	C	02	I	5	C	12	I : E3U11
	C: Cable	Length 02: 2M 05: 5M 10: 10M	Connector I: Straight L: Angled	Pole 4: 4 5: 5	Material R: PUR C: PVC S: PVC Shielded wire	Size 12: M12	L : E3U12

Order No.	US0001	US0002	US0003	US0007	US0009	US0023
Type						
Drawing No.	E3U01	E3U02	E3U03	E3U07	E3U08	E3U09

* US0023 is used for low flow rate

Drawing

Page	>>> P. 50-53
------	--------------

Order NO.

Order NO.	Thread Type	Thread	Sensible Range Liquid (cm/s)	Sensible Range gas (cm/s)	Output	Probe Length (mm)	Supply Voltage (V)	Drawing No.
FL6201	Internal	M18x1.5	3~300	200~3000	PNP NO/NC	45	20~36 DC	E3F03
FL6202	Internal	M18x1.5	3~300	200~3000	NPN NO/NC	45	20~36 DC	E3F03

Technical parameters:

Housing/Probe material: Stainless steel 316L
 Connection: M12 Socket
 Pressure rating [bar]: 300
 Max. current load [mA]: 2 x 400
 Voltage drop [V]: < 2.5
 Power-on delay time [s]: < 8
 Output response time [s] : < 2
 Temperature display accuracy[°C]: ± 0.5
 Medium temperature[°C]: -25...80



- Setting by potentiometer
- No pressure lose
- Full pass flow tube
- Extremely wide flow range
- Different kinds of flow medium can be measured
- Simple indication, Highly reliability
- Robust housing/probe stainless steel 316L
- Protection: IP68



Accessories:

US0041



G1/2"- Ø24mm

E3U13

Order NO.

Order NO.	Thread Type	Thread	Sensible Range Liquid (cm/s)	Sensible Range gas (cm/s)	Output	Probe Length (mm)	Supply Voltage (V)	Drawing No.
FL6301	External	G1/2"A	3~300	200~3000	PNP/NPN NO	45	20~36 DC	E3F04
FL6302	External	G1/2"A	3~300	200~3000	PNP/NPN NC	45	20~36 DC	E3F04

Drawing

Page

>>> P. 50–53

Technical parameters:

Housing/Probe material: Stainless steel 316L
 Connection: M12 Socket
 Pressure rating [bar]: 300
 Max. current load [mA]: 400
 Voltage drop [V]: < 2.5
 Power-on delay time [s]: < 8
 Output response time [s] : < 2
 Medium temperature [°C]: -25...80
 Liquid SP setting [cm/s]: Adjustable via potentiometer (Factory setting: 15)
 Gas SP setting [cm/s]: Adjustable via potentiometer (Factory setting: 150)



- Used for long-distance flow measurement
- Three combined units: controller, cable, probe
- Users can set flow range and switch point via buttons easily
- Embedded high precision sensing chip and suitable for gas and liquid
- All stainless steel structure and protection rating is up to IP68



Accessories:

Type	Connector Order No.						Drawing No.
 I L	C	02	I	5	C	12	I : E3U11
	C: Cable	Length 02: 2M 05: 5M 10: 10M	Connector I: Straight L: Angled	Pole 4: 4 5: 5	Material R: PUR C: PVC S: PVC Shielded wire	Size 12: M12	L : E3U12

Order No.	US0001	US0002	US0003	US0007	US0009	US0023
Type						
	M18 x 1.5 – M12 x 1	M18 x 1.5 – G1/4"	M18 x 1.5 – G1/2"	M18 x 1.5 – Ø24mm	M18 x 1.5 – M18 x 1.5	M18 x 1.5 – G1/4"
Drawing No.	E3U01	E3U02	E3U03	E3U07	E3U08	E3U09

* US0023 is used for low flow rate

Drawing

Page >>> P. 50-53

Order NO.

Control monitors

Order NO.	Thread Type	Thread	Sensible Range Liquid (cm/s)	Sensible Range gas (cm/s)	Output	Probe Length (mm)	Supply Voltage (V)	Drawing No.
FL6401	External	G1/2"A	3~300	200~3000	PNP NO/NC	None	20~36 DC	E3F05
FL6402	External	G1/2"A	3~300	200~3000	NPN NO/NC	None	20~36 DC	E3F05
FL6403	External	G1/2"A	3~300	200~3000	RELAY NO/NC	None	20~36 DC	E3F05
FL6404	External	G1/2"A	3~300	200~3000	RELAY NO/NC	None	85~265 AC	E3F05

Probe

Order NO.	Thread Type	Thread	Sensible Range Liquid (cm/s)	Sensible Range gas (cm/s)	Output	Probe Length (mm)	Supply Voltage (V)	Drawing No.
FL6410	Internal	M18"x1.5	None	None	None	45	None	None

Type	Cable Order No.						Drawing No.
 C J	C	02	J	5	R	12	J : E3U10
	C: Cable	Length 02: 2M 05: 5M 10: 10M	J : Jumper male/female	Pole 5: 5	R: PUR	Size 12: M12	

Technical Parameters

Housing/Probe material: Stainless steel 316L
 Connection: M12 Socket
 Pressure rating [bar]: 300
 Max. current load [mA]: 400
 Voltage drop [V]: < 2.5
 Power-on delay time [s]: < 8
 Output response time [s]: < 2
 Medium temperature [°C]: -25...80

Flow Sensors
Pressure Sensors
Temperature Sensors



- Output function: can be converted by dip switches
- Sensing substance: gas, liquid
- Display: LED
- Power protection: overload, reverse polarity
- Explosion proof classification: Exd II CT6



Accessories:

Order No.	US0001	US0002	US0003	US0007	US0009	US0023
Type						
Drawing No.	E3U01	E3U02	E3U03	E3U07	E3U08	E3U09

* US0023 is used for low flow rate

Drawing

Page >>> P. 50-53

Order NO.

Order NO.	Thread Type	Thread	Sensible Range Liquid (cm/s)	Sensible Range gas (cm/s)	Output	Probe Length (mm)	Supply Voltage (V)	Drawing No.
FL2001	Internal	M18 x 1.5	3~300	200~3000	PNP NO/NC	45	20~36 DC	E3F06
FL2002	Internal	M18 x 1.5	3~300	200~3000	NPN NO/NC	45	20~36 DC	E3F06

Technical parameters:

Housing/Probe material: Stainless steel 316L
 Connection: Terminal
 Pressure rating [bar]: 300
 Max. current load [mA]: 400
 Voltage drop [V]: < 2.5
 Power-on delay time [s]: < 8
 Output response time [s] : < 2
 Medium temperature [°C]: -25...80



- This electronic flow sensors meet the standard of hygienic design
- Embedded high precision sensing chip and suitable for gas and liquids
- Elegant design, smooth surface, anti-acid, anti-alkali and anti-corrosion
- Users can set flow range and switch point via buttons easily
- All stainless steel structure and the rating is up to IP69K



Accessories:

Type	Connector Order No.						Drawing No.
	C	02	I	5	C	12	I : E3U11
	C: Cable	Length 02: 2M 05: 5M 10: 10M	Connector I: Straight L: Angled	Pole 4: 4 5: 5	Material R: PUR C: PVC S: PVC Shielded wire	Size 12: M12	L : E3U12

Order No.	US0063	US0064
Type	 Hygienic welding adapter	 Hygienic Tri Clamp adapter
Drawing No.	E3U17	E3U18

Drawing

Page >>> P. 50-53

Order NO.

FL33 Sanitary Flow sensors

Order NO.	Thread Type	Thread	Sensible Range Liquid (cm/s)	Sensible Range gas (cm/s)	Output	Probe Length (mm)	Supply Voltage (V)	Drawing No.
FL3301	External	G1"A	3~300	200~3000	PNP NO/NC	45	20~36 DC	E3F02
FL3302	External	G1"A	3~300	200~3000	NPN NO/NC	45	20~36 DC	E3F02

FL331X Sanitary Flow and Temperature Sensors

Order NO.	Thread Type	Thread	Sensible Range Liquid (cm/s)	Sensible Range gas (cm/s)	Output	Probe Length (mm)	Supply Voltage (V)	Drawing No.
FL3311	External	G1"A	3~300	200~3000	PNP NO/NC	45	20~36 DC	E3F02
FL3312	External	G1"A	3~300	200~3000	NPN NO/NC	45	20~36 DC	E3F02

Flow Sensors

Pressure Sensors

Temperature Sensors

Technical parameters:

Housing/Probe material: Stainless steel 316L
 Connection: M12 Socket
 Pressure rating [bar]: 300
 Max. current load [mA]: 400
 Voltage drop [V]: < 2.5
 Power-on delay time [s]: < 8
 Output response time [s] : < 2
 Medium temperature [°C]: -25...95